



Interchim HTHR

High Throughput. High Resolution.

Strategy™ UPLC and HPLC columns

Interchim Strategy™

Strategy columns redefine the boundaries for high throughput analysis by maximizing resolution without sacrificing speed.

The enhanced performance and low back pressure is a result of phase features, a revolutionary packing process and the cylindrical pore structure of the base silica.

Offered in eight phases the Strategy 1.7 μ and 2.2 μ columns are suitable for a wide range of polar, mid-polar and non-polar compounds. The low surface energy ensures peak symmetry for even the most basic compounds.

The well hydroxylated surface and high surface area (425m²/g) maximizes the loading capacity and provides excellent pH stability from 1 to 10.

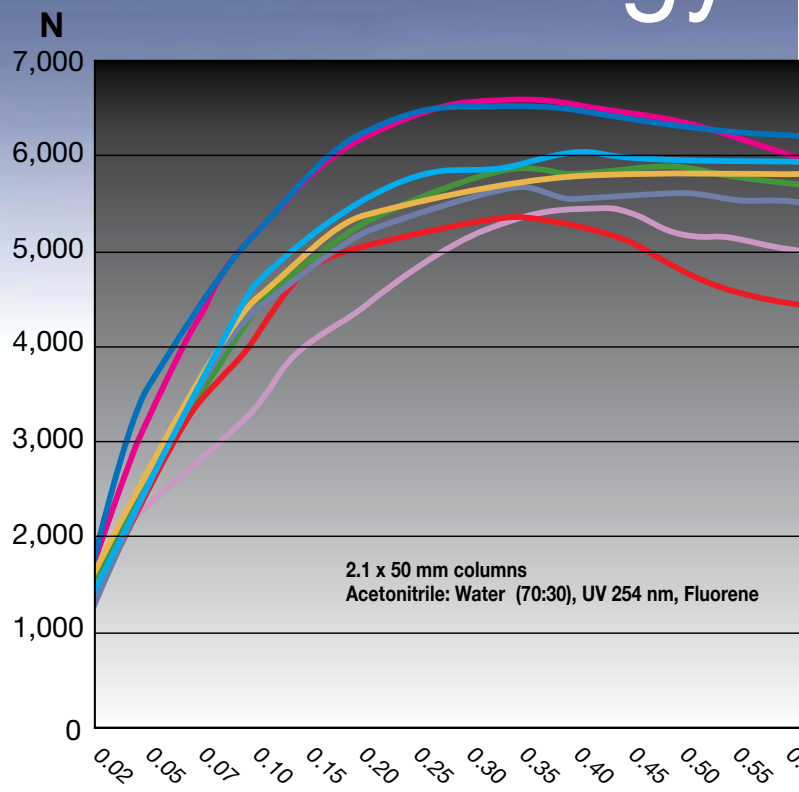

Compared to the competition, Strategy maintains high separation efficiency for high throughput analysis.

- Strategy 1.7 μ C18-2
- Competitor A, 1.7 μ C18
- Strategy 2.2 μ C18-2
- Competitor B, 1.8 μ C18
- Strategy 2.2 μ NEC
- Competitor C, 1.8 μ C18
- Strategy 2.2 μ PRO
- Competitor D, 1.8 μ C18

Strategy: 1.7 μ C18-2, 4.6 x 50 mm				Strategy: 2.2 μ C18-2, 4.6 x 50 mm			
ml/min	PSI	As	Plates	ml/min	PSI	As	Plates
1.00	1915	1.21	9177	1.00	972	1.09	8724
1.30	2553	1.25	10362	1.30	1218	1.12	9332
1.50	2915	1.23	10825	1.50	1421	1.13	9177
1.80	3437	1.22	10743	1.80	1711	1.12	9167
2.00	3786	1.21	10568	2.00	1929	1.18	8940
2.30	4337	1.18	10424	2.30	2219	1.14	8899
2.50	4714	1.21	10094	2.50	2379	1.12	8755
2.80	5279	1.17	10012	2.80	2669	1.14	8570
3.00	5700	1.21	9713	3.00	2944	1.14	8271

Acetonitrile: Water (70:30), UV 254 nm, 22C, Fluorene

HTHR

– High Throughput. High Resolution. UPLC and



200,000 plates/m, 2900 psi

Strategy columns exhibit high permeability that allow higher flow rates compared to other ~2 μ columns. High pressure benefits are realized and the analysis can be performed at high flow rates without compromising the separation.

Uptisphere® Strategy:
 2.2 μ m C18-2, 50 x 4.6 mm
Part Number: XA3980
Flow: 1.3 ml/min
Pressure: 84 bar/1218 psi
Plates/col : 9332

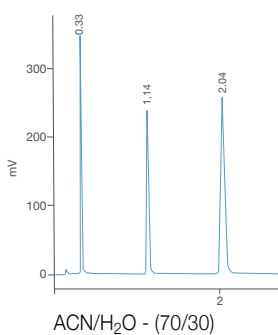

Fluorene
 Tr: 2.04 min
 As: 1.12

Uptisphere® Strategy:
 1.7 μ m C18-2, 50 x 4.6 mm
Part Number: XA3860
Flow: 1.5 ml/min
Pressure: 201 bar/2915 psi
Plates/col : 10825

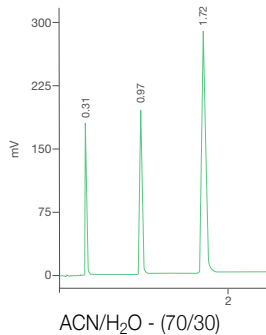

Fluorene
 Tr: 1.72 min
 As: 1.23

1 minute separation of Furosemid in rat plasma

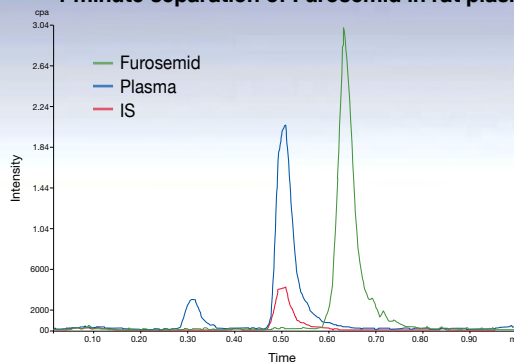

Strategy: 1.7 μ C18-2, 2.1 x 50 mm
Part Number: XA3780

Agilent: 1200 RRLC + Qtrap 4000
Solvent A: 0.1% CH₃COOH
Solvent B: ACN + 0.1% CH₃COOH
Isocratic: (50/50)
Flow rate: 600 μ l/min @ 500 bars (7000 psi)
LD: 2.14 μ g/L
Injection: 10 μ l

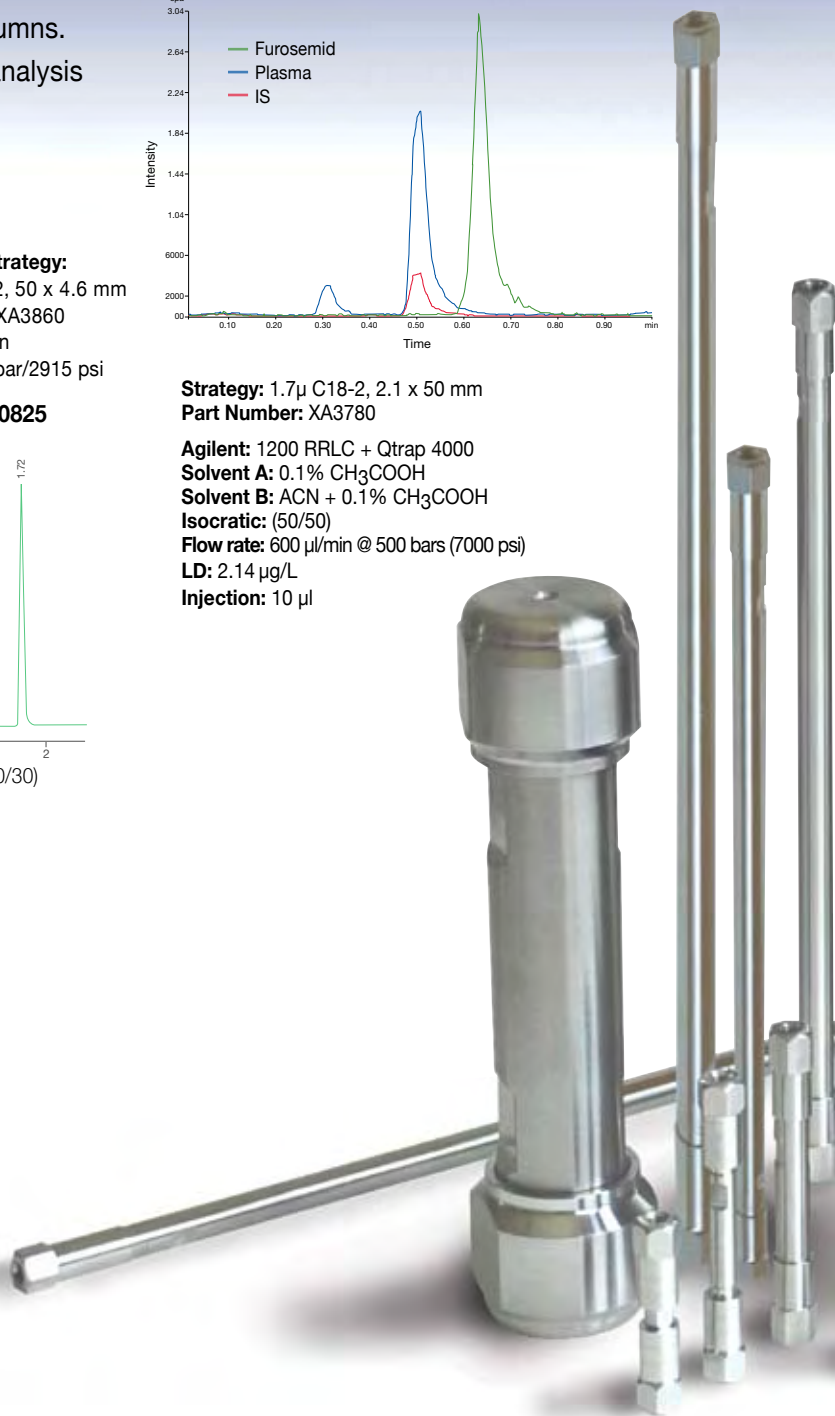

HPLC.

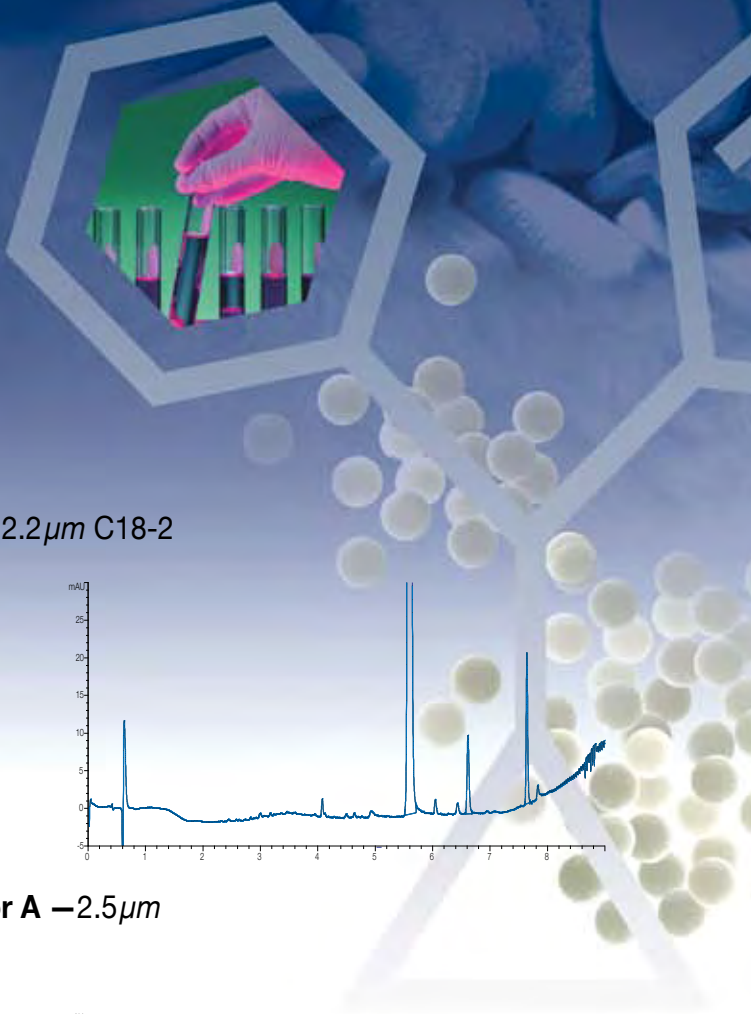

Strategy — 2.2 μm C18-2

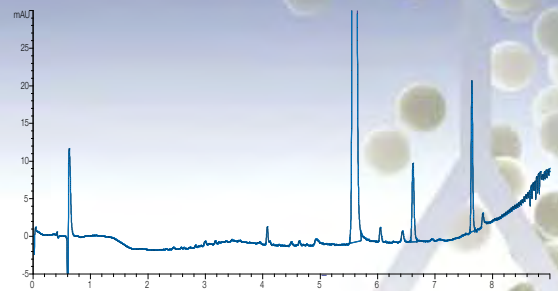
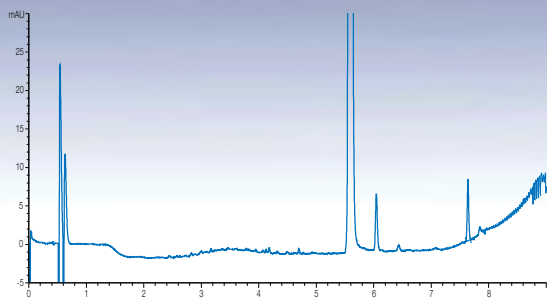

Competitor A — 2.5 μm

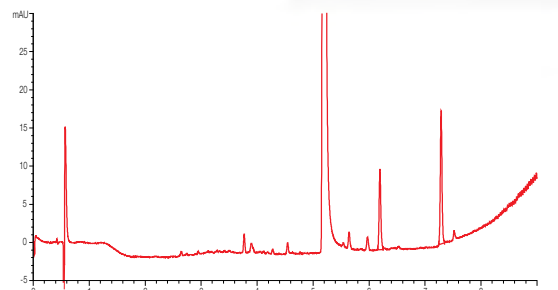
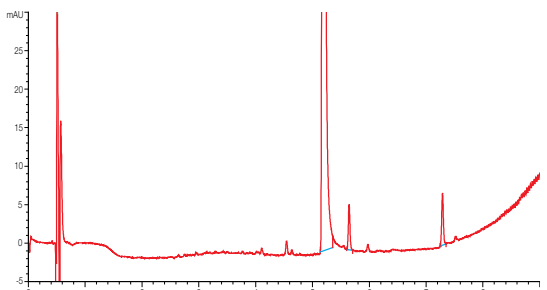

Competitor B — 1.8 μm

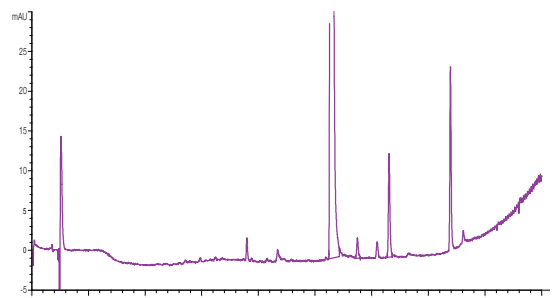
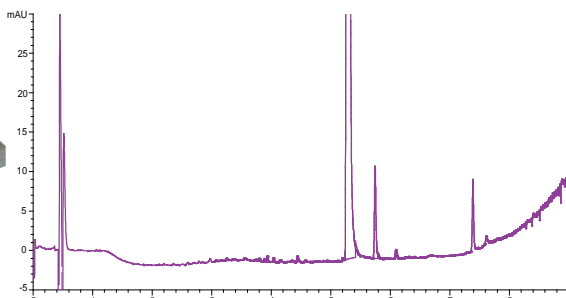

Eluent:
A: 10mM NH_4HCO_3 (pH10)
B: MeCN
Gradient:
A/B 95/05 (lin. grad. 6 min)
A/B 50/50 (lin. grad. 2 min)
A/B 05/95 (1 min)
Flow: 1.25 ml/min
Columns : 50 x 4, 6 mm

Customer Notes :

“Better selectivity for mid-polar and non polar compounds, Good symmetry, interesting to obtain same results with 1.7 μm and 2.2 μm ”

Strategy C18-2: 2.2 μm , 2.1 x 150 mm

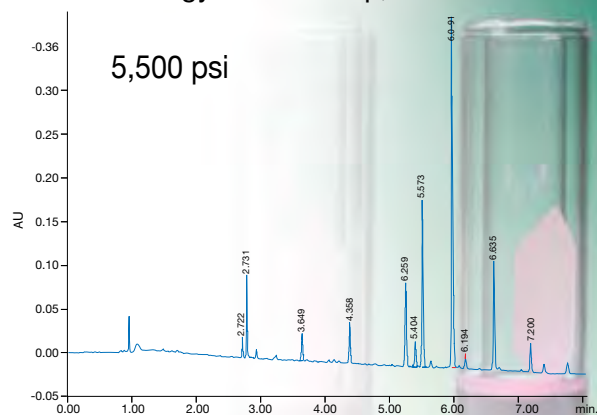

Competitor C18: 1.7 μm , 2.1 x 150 mm

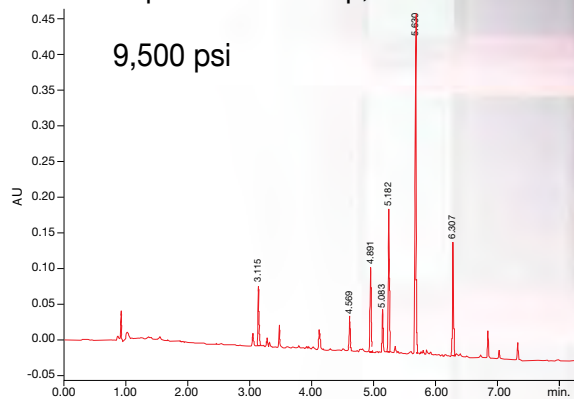

Interchim HTHR

High Throughput. High Resolution.

Strategy/Ordering Information

	C18-2, 1.7 μ	HILIC, 1.7 μ	C18-2, 2.2 μ	NEC, 2.2 μ	Pro, 2.2 μ	PLP, 2.2 μ	NH2, 2.2 μ	HILIC, 2.2 μ	Si, 2.2 μ	Price
2.1 x 100 mm	XA3790	XA5260	XA3910	XA4390	XA4510	XA8190	XA8060	XA4030	XA4150	615
2.1 x 150 mm	XA3800	XA5270	XA3920	XA4400	XA4520	XA8200	XA8070	XA4040	XA4160	725
2.1 x 25 mm	XA3770	XA4900	XA3890	XA4370	XA4490	XA8160	XA8030	XA4010	XA4130	299
2.1 x 30 mm	XA4780	XA8800	XA4790	XA5650	XA5640	XA8170	XA8040	XA5320	XA5970	355
2.1 x 50 mm	XA3780	XA4910	XA3900	XA4380	XA4500	XA8180	XA8050	XA4020	XA4140	500
3.0 x 100 mm	XA3830	XA4840	XA3950	XA4430	XA4550	XA8230	XA8100	XA4070	XA4190	615
3.0 x 150 mm	XA3840	XA4850	XA3960	XA4440	XA4560	XA8240	XA8110	XA4080	XA4200	725
3.0 x 25 mm	XA3810	XA5280	XA3930	XA4410	XA4530	XA8210	XA8080	XA4050	XA4170	299
3.0 x 50 mm	XA3820	XA5290	XA3940	XA4420	XA4540	XA8220	XA8090	XA4060	XA4180	500
4.6 x 100 mm	XA3870	XA4880	XA3990	XA4470	XA4590	XA8270	XA8140	XA4110	XA4230	615
4.6 x 150 mm	XA3880	XA4890	XA4000	XA4480	XA4600	XA8280	XA8150	XA4120	XA4240	725
4.6 x 25 mm	XA3850	XA4860	XA3970	XA4450	XA4570	XA8250	XA8120	XA4090	XA4210	299
4.6 x 50 mm	XA3860	XA4870	XA3980	XA4460	XA4580	XA8260	XA8130	XA4100	XA4220	500

Strategy is offered in eight phases to provide a wide range of selectivity

Phase	Pore Size	Surface Area	Surface chemistry	% C	pH range	Application
C18-2	100 Å	425 m ² /g	C18	19%	1 - 10	General purpose reverse phase, mid to non-polar compounds.
NEC	100 Å	425 m ² /g	C18	18%	1.5 - 7	Strongly retains polar and mid-polar compounds.
PLP	100 Å	425 m ² /g	Alkyl chain w/ polar embedded group	14%	2.5 - 7.5	High aqueous mobile phase with basic and polar compounds.
PRO	100 Å	425 m ² /g	C12	16%	1.5 - 8	Non polar compounds. Less retentive than C18 with greater capacity.
RPX	100 Å	425 m ² /g	Proprietary, reverse phase	-	1.5 - 7	Mid polar and non polar compounds. Less retentive than C18.
HILIC	100 Å	450 m ² /g	Proprietary, reverse phase	NA	1.5 - 7	Ideal for highly polar and basic compounds which do not retain well in RP.
SI	100 Å	425 m ² /g	Virgin silica	NA	1.5 - 7	Non-ionic, polar organic compounds.
NH2	100 Å	425 m ² /g	NH ₂	4%	1.5 - 7	Carbohydrates, polar organic compounds and organic acids.

For a complete price list call: 800.560.8262 or email: HTHR@interchiminc.com

Visit www.interchiminc.com

for more innovative products

Atoll™ SPE Columns

1500 m²/g polymer SPE for 50% higher loading

puriFlash™ Columns

Flash Columns with 30 and 50 μ super-efficient silica

puriFlash™ 430 Instrument

1.0 - 200ml/min, 450 psi, Quaternary Gradient

Interchim, Inc.

1536 West 25th Street, Suite 452

San Pedro, CA 90732

Tel: 800.560.8262

Fax: 310.802.3877

email: HTHR@interchiminc.com

