

COSMOSIL

COSMOSIL

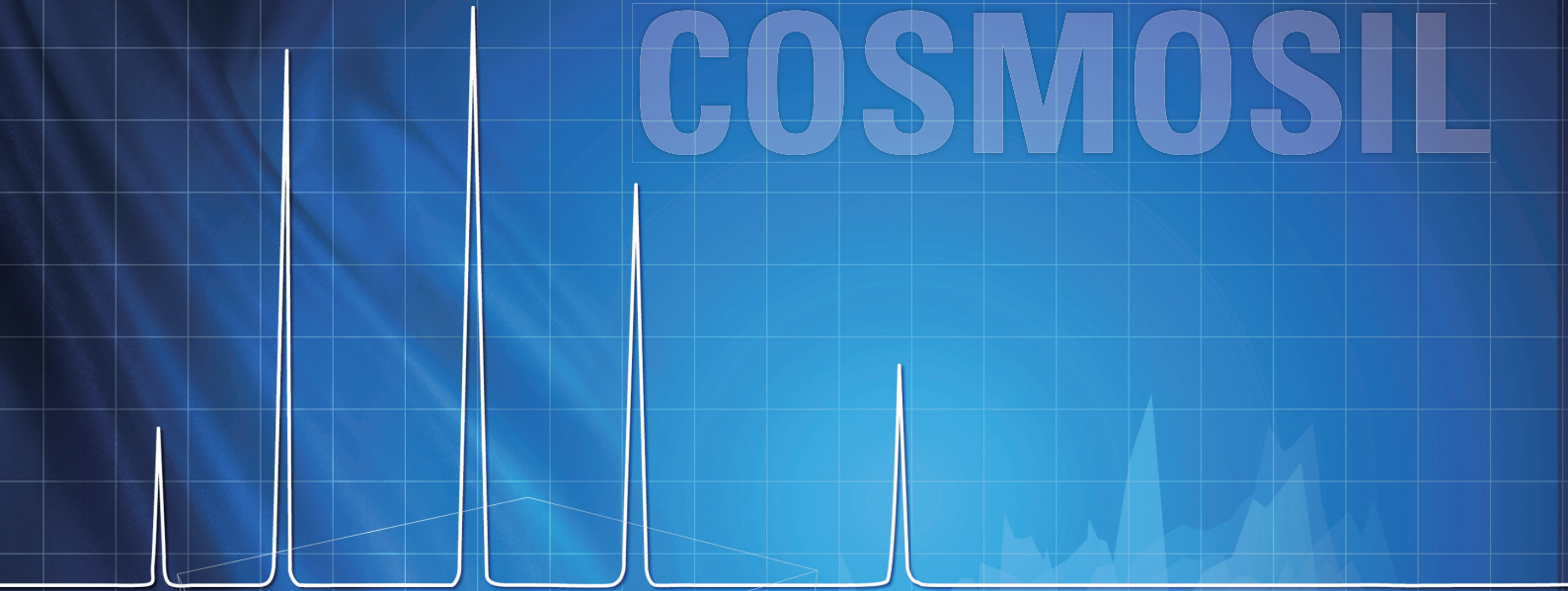

2012-2013

**High Performance
Liquid Chromatography**

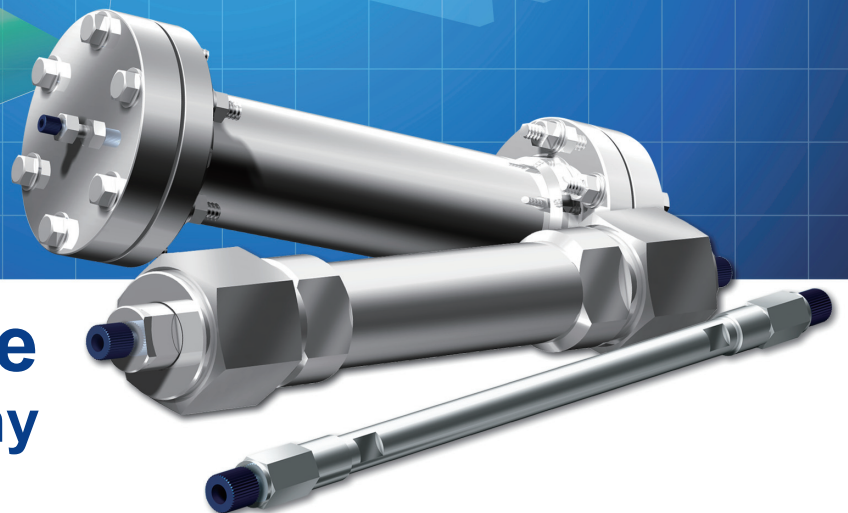



COSMOSIL

COSMOSIL Application

COSMOSIL Application has more than 7,000 applications using COSMOSIL columns. Setting optimal HPLC experimental parameters is the one of the most important processes that requires experience and time. COSMOSIL Application provides you with sample analysis conditions with widely used ODS columns and other specialty columns.

- Over 7,000 applications
- Easy to search

Visit COSMOSIL top page at <http://www.nacalai.co.jp/global/cosmosil/>

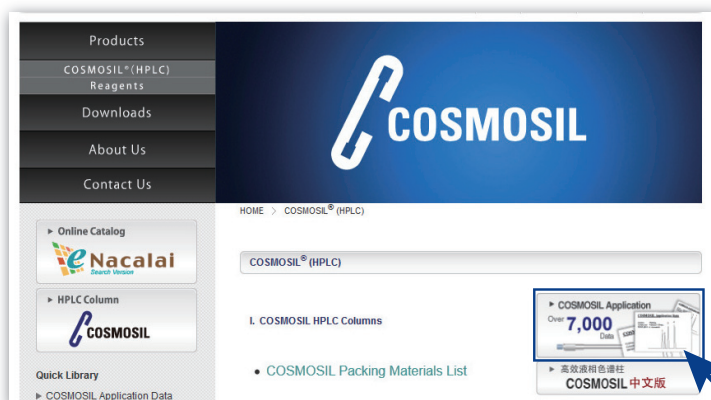

Click

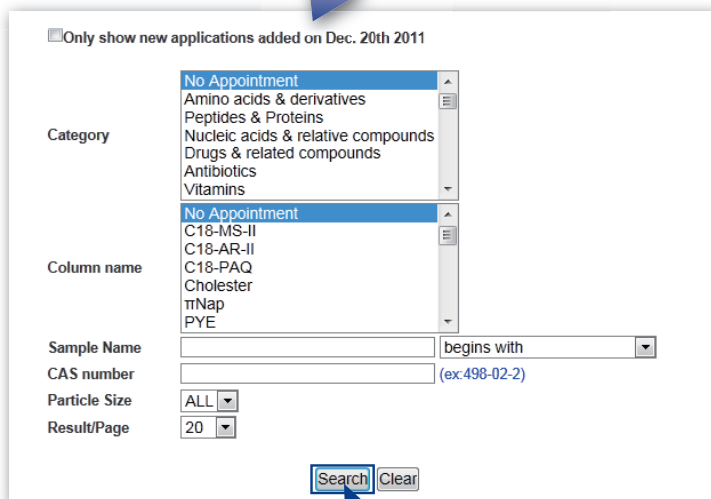

Applications are search by

1. Sample Category
2. Sample Name
3. CAS No.,
4. Column Name
5. Particle Size

Search Result

Click

COSMOSIL Application

Search condition: [Column=mNap]

[TOP]

Results 24 (1-20) [Next]

Data No.	Data Name	Sample	Particle Size (µm)	Column	CAS No.
AP-1206	Dichlorophenol	2,3-Dichlorophenol	5	mNAP	576-24-9
		2,4-Dichlorophenol			120-83-2
		2,5-Dichlorophenol			583-78-8
		2,6-Dichlorophenol			87-65-0

Click

COSMOSIL Application

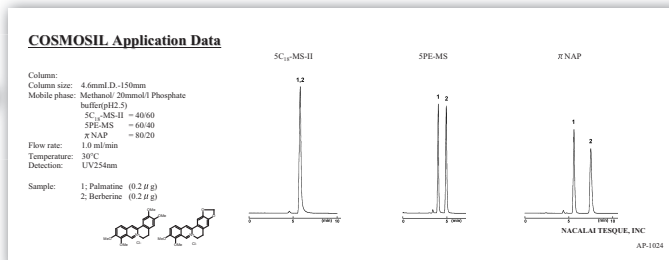

Packing Material List

Sample	Separation Mode	Packing Material	Stationary Phase	Special Features and Applications	USP Category	Page	
Organic Compounds (low M.W.)	Reversed Phase	C ₁₈ -MS-II	Octadecyl Group	Multi-purpose C ₁₈ column. Monofunctional silylation on ultra-pure silica gel for separation of widest range of compounds.	L1	14, 62	
		C ₁₈ -AR-II		Multi-purpose C ₁₈ column using ultra-pure silica gel. Features strong acid resistance and suitable for a wide range of separation.	L1	16	
		C ₁₈ -PAQ		Reversed phase column, compatible with 100% water based mobile phases.	L1	18	
		Cholester	Cholesteryl Group	Usable under the same condition as C ₁₈ . Unique rigid cholesteryl structure improves separation.		21, 62	
		πNAP	Naphthylethyl Group	Stronger π-π interaction than phenyl column		24, 62	
		PYE	Pyrenylethyl Group	The most powerful π-π interaction	Coming soon	26	
		NPE	Nitrophenylethyl Group	Separation utilizing π-π interaction and Dipole-dipole interaction		28	
		PBB-R	Pentabromobenzyl Group	Separation utilizing dispersion force		29	
		CN-MS	Cyanopropyl Group	Great reproducibility using isocratic elution mode	L10	31	
		C ₂₂ -AR-II	Docosyl Group	Alkyl chain columns except C ₁₈ column			32
		C ₈ -MS	Octyl Group			L7	
		C ₄ -MS	Butyl Group			L26	
		TMS-MS	Trimethyl Group			L13	
		PE-MS	Phenylethyl Group	π-π interaction		L11	
Normal Phase	SL-II	--	Normal phase chromatography with non-polar organic solvents	L3	34		
Hydrophilic Interaction	HILIC	Triazole	Retains highly polar compounds that would not be retained in C ₁₈ column		36		
Mono- and Oligosaccharides	Hydrophilic Interaction	Sugar-D	Secondary/Tertiary Amine	A novel stationary phase for saccharide separation. Extended column life and increased stability. Alternative to aminopropyl type		39	
		NH ₂ -MS	Aminopropyl Group	Primary amino bonded column		41	
Proteins	Reversed Phase	Protein-R	Octadecyl Group	The most suitable reversed phase column for proteins		42	
		C ₁₈ -AR-300	Octadecyl Group	Wide pore type reversed phase columns with high acid resistance recommended for the separation of proteins, polypeptides, nucleic acids and other large molecules.	L1	44	
		C ₈ -AR-300	Octyl Group		L7		
		C ₄ -AR-300	Butyl Group		L26		
		Ph-AR-300	Pyrenyl Group		L11		
	Gel Permeation	Diol-120-II	Diol Group	Silica-based gel filtration column for high speed separation of proteins and water soluble polymer	L20	46	
		Diol-300-II					
	NEW Ion-exchange		IEX Type Q	Trimethylaminopropyl Type	Anion-exchange Type (purification)	48	
			IEX Type Q-N		Anion-exchange Type (ultra-fast analysis, precise analysis)		
			IEX Type S	Sulfopropyl Type	Cation-exchange Type (purification)		
			IEX Type S-N		Cation-exchange Type (ultra-fast analysis, precise analysis)		
IEX Type M			Trimethylaminopropyl Type/ Sulfopropyl Type	Amphoteric ion-exchange Type (purification)			
IEX Type M-N	Amphoteric ion-exchange Type (precise analysis)						
Hydrophobic Interaction	HIC	--	Hydrophobic interaction chromatography column for protein separation		51		
Fullerenes	--	Buckyprep	Pyrenylpropyl Group	Standard column for fullerenes separation		54	
		Buckyprep-M	Phenothiazinyl Group	Designed to separate metallofullerenes		55	
		PBB	Pentabromobenzyl Group	Designed for the preparative separation of fullerenes using carbon disulphide, o-dichlorobenzene and toluene		56	
		NPE	Nitrophenylethyl Group	Separation of derivatived fullerenes		57	
		PYE	Pyrenylethyl Group	Separation of fullerenes and structural isomers			
Carbon Nanotubes	Gel Permeation	CNT-300	Hydrophilic Group (neutral)	Separation of soluble carbon nanotubes		58	
		CNT-1000					
		CNT-2000					

For old type columns, please refer to page 59.

COSMOSIL/COSMOGEL Column Chromatography Packing Materials

Separation Mode	Application	Packing Material	Feature	Page
Reversed Phase	Open, Flash, Medium Pressure Chromatography	C ₁₈ -OPN	Usable under 100% aqueous eluents.	67
		C ₁₈ -PREP	End-capping treated.	70
Normal Phase		SL-II-PREP	Ultra pure silica gel is used.	71

Column Selection Guide

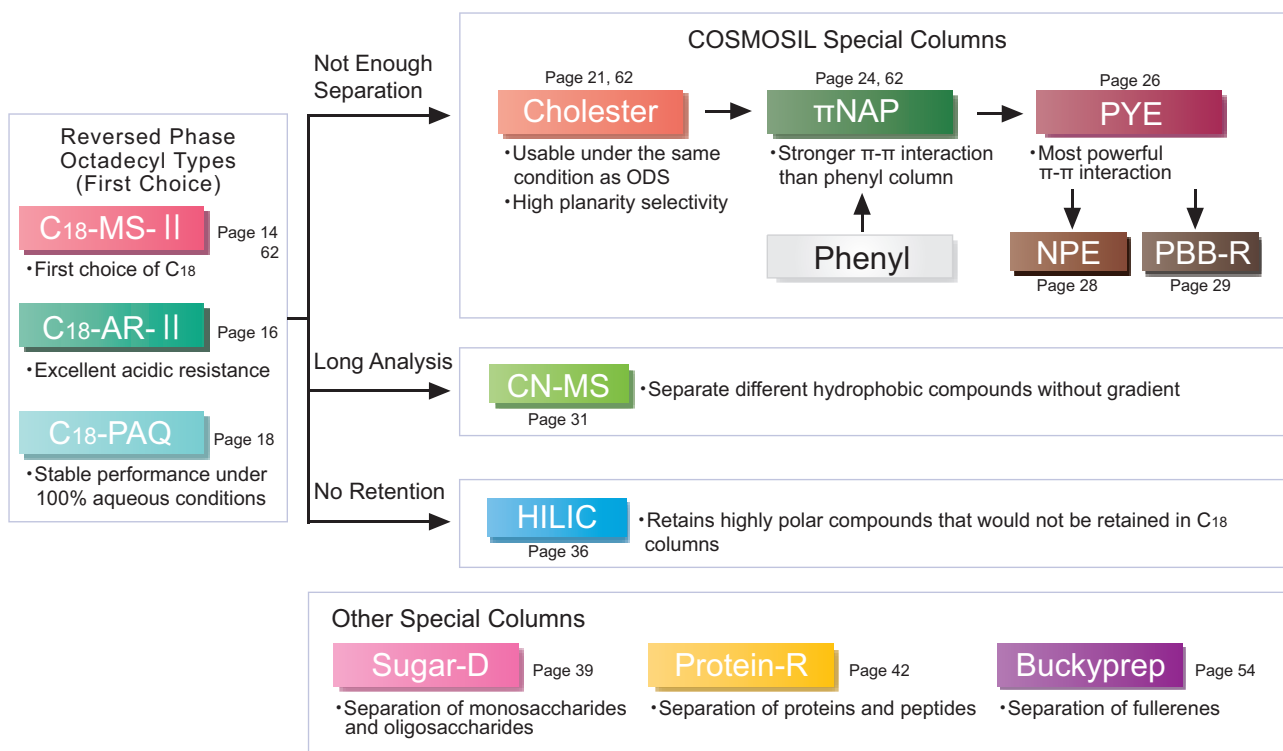

COSMOSIL USP List

USP No.	Phase	USP Description	Product Name
L01	C ₁₈	Octadecyl silane <ODS or C ₁₈ > chemically bonded to porous silica or ceramic particles, 1.5 to 10 micron in diameter, or a monolithic rod.	COSMOSIL 5C ₁₈ -MS-II COSMOSIL 5C ₁₈ -AR-II COSMOSIL 5C ₁₈ -PAQ COSMOSIL 5C ₁₈ -AR-300 COSMOSIL 2.5C ₁₈ -MS-II
L03	SIL	Porous silica particles, 5 to 10 micron in diameter, or a monolithic rod.	COSMOSIL 5SL-II
L07	C ₈	Octylsilane <C ₈ > chemically bonded to porous silica particles, 1.5 to 10 micron in diameter, or a monolithic rod.	COSMOSIL 5C ₈ -MS COSMOSIL 5C ₈ -AR-300
L10	CN	Nitrile groups <CN> chemically bonded to porous silica particles, 3 to 10 micron in diameter.	COSMOSIL 5CN-MS
L11	Ph	Phenyl groups chemically bonded to porous silica particles, 1.5 to 10 micron in diameter.	COSMOSIL 5PE-MS COSMOSIL 5Ph-AR-300
L13	C ₁	Trimethylsilane <C ₁ > chemically bonded to porous silica particles, 3 to 10 micron in diameter.	COSMOSIL 5TMS-MS
L20	Diol	Dihydroxypropane groups chemically bonded to porous silica particles, 5 to 10 micron in diameter.	COSMOSIL Diol-120-II COSMOSIL Diol-300-II
L26	C ₄	Butyl silane <C ₄ > chemically bonded to porous silica particles, 3 to 10 micron in diameter.	COSMOSIL 5C ₄ -MS COSMOSIL 5C ₄ -AR-300

COSMOSIL Column Size List

Particle Size 5 μm, 15 μm	Length (mm)										
	10	20	30	50	75	100	125	150	250	500	
Inner Diameter (mm)	1.0	+	+	+	++	+	++	+	+	+	+
	2.0	+	+	++	++	+	++	+	++	++	+
	3.0	+	+	+	+	+	++	+	++	++	+
	4.6	+	+	++	++	+	++	+	++	++	+
	6.0	+	+	+	+	+	+	+	++	++	+
	8.0	+	+	+	+	+	+	+	+	+	+
	10.0	+	+	+	++	+	+	+	++	++	+
	20.0	+	+	+	++	+	+	+	++	++	+
	28.0	+	+	+	+	+	+	+	+	++	+
	50.0	+	+	+	+	+	+	+	+	++	++

++ Catalog Listed Size
+ Inquire Price and Lead Time

In addition to the original column sizes listed in this catalog, other sizes may be available. Please contact us at info.intl@nacalai.com for more information.

CORPORATE PROFILE

Nacalai Tesque dates back to 1846 when the company's founder Mansuke Nakarai opened Nakarai Mansuke Shoten, Ltd., an apothecary selling traditional Japanese and Chinese medicines. In 1958, this company's reagent department became an independent company, Nakarai Chemicals, Ltd.

The company has since dedicated itself to expanding its corporate base and has strived to be an enterprise that our customers always rely on, while taking pride in its contribution to scientific and industrial development.

Making the most of this 30-year history and as a step toward the future, Nakarai Chemicals changed its corporate name to Nacalai Tesque, Inc. in 1988. At Nacalai Tesque, we have fostered a corporate commitment to the pursuit of reliable quality and the creation of products of real value, while serving as a vital link between humanity and science. Centering around research chemicals, the fields of our activities include fine chemicals, diagnostics and related laboratory equipment and supplies.

The pace of scientific and technological progress in every industrial field is rapidly accelerating, and all business partners and affiliates are required to provide even more diversified and advanced expertise.

It is our corporate policy to strive for our lofty ideals for excellence while respecting our long history and tradition. We consider it our mission to maintain close contact with our customers by offering reliable quality in all our products, information and services, and by making full use of the knowledge and experience of our staff.

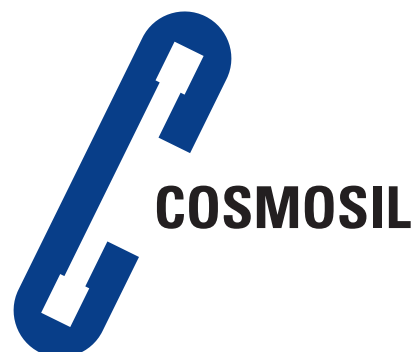

INDEX

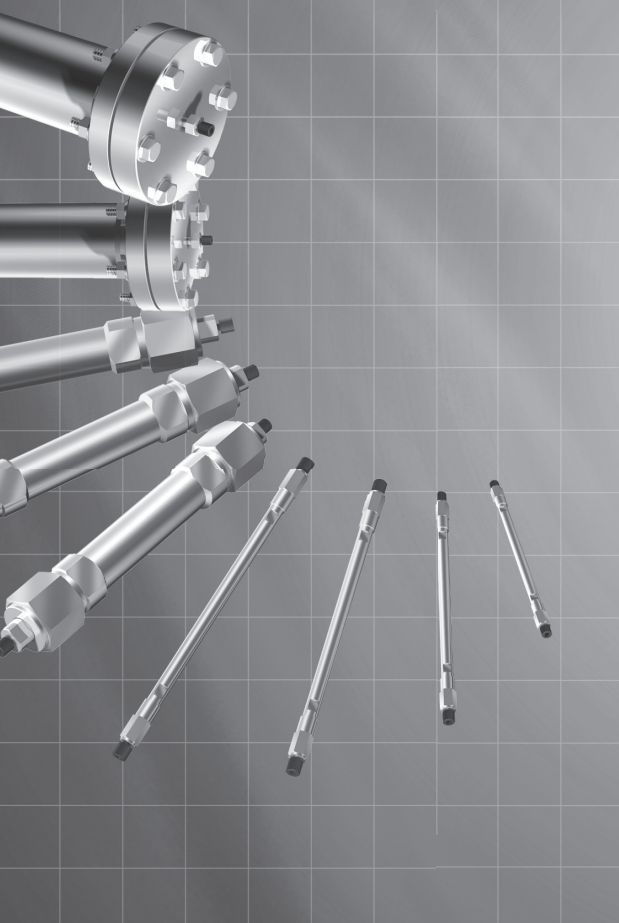

CORPORATE PROFILE	1
INDEX	2
General Information	4
I. HPLC Columns	
1. COSMOSIL/COSMOGEL HPLC Columns	6
2. Column Selection Guide	7
3. COSMOSIL Silica Packing Material	8
4. Performance Guarantee	10
(1) Quality Guarantee of Packing Materials	10
(2) Quality Guarantee of COSMOSIL Packed Columns	11
5. Reversed Phase Chromatography Columns	12
(1) C ₁₈ (ODS) Series	12
COSMOSIL C ₁₈ -MS-II	14
COSMOSIL C ₁₈ -AR-II	16
COSMOSIL C ₁₈ -PAQ	18
(2) Special Columns	20
COSMOSIL Cholester	21
COSMOSIL πNAP	24
COSMOSIL PYE	26
COSMOSIL NPE	28
COSMOSIL PBB-R	29
(3) Other Reversed Phase HPLC Columns	30
COSMOSIL CN-MS	31
COSMOSIL C ₂₂ -AR-II, C ₈ -MS, C ₄ -MS, TMS-MS, PE-MS	32
(4) Silica Based Preparative Columns	33
COSMOSIL 15C ₁₈ -MS-II, 15C ₁₈ -AR-II, 15C ₁₈ -PAQ	33
6. Normal Phase Chromatography Column	34
COSMOSIL SL-II	34
7. Hydrophilic Interaction Chromatography Column	36
COSMOSIL HILIC	36
8. Mono- and Oligosaccharide Analysis Columns	38
COSMOSIL Sugar-D	39
NH ₂ -MS	41
9. Protein Separation Columns	42
(1) Reversed Phase Chromatography	42
COSMOSIL Protein-R	42
COSMOSIL C ₁₈ -AR-300, C ₈ -AR-300, C ₄ -AR-300, Ph-AR-300	44
(2) Gel Filtration Chromatography Column (aqueous)	46
COSMOSIL Diol-120-II, Diol-300-II	46
(3) Ion Exchange Chromatography Column	48
COSMOGEL IEX Series	48
(4) Hydrophobic Interaction Chromatography Column	51
COSMOSIL HIC	51
10. Columns for Fullerene Separation	52
COSMOSIL Buckyprep	54
COSMOSIL Buckyprep-M	55
COSMOSIL PBB	56
COSMOSIL NPE	57
COSMOSIL PYE	57
11. Columns for Soluble Carbon Nanotube Separation	58
COSMOSIL CNT-300, CNT-1000, CNT-2000	58
12. Conventional Columns	59
II. UHPLC Columns	
COSMOSIL 2.5C ₁₈ -MS-II, 2.5Cholester, 2.5πNAP	62
III. Preparative Packing Materials	
1. Normal and Reversed Phase Packing Materials	66
COSMOSIL C ₁₈ -OPN	67



COSMOSIL C ₁₈ -PREP	70
COSMOSIL SL-II-PREP	71
Silica Gel (spherical, neutral)	72
Silica Gel (for column chromatograph)	73

IV. Related Products

1. Reagents for Mobile Phase Preparation	76
Solvents, Additives	76
Phosphate Buffer Solution (pH 2.5) (5x)	77
Ion-pair Reagents	78
2. Prefiltration Tool for Liquid Chromatography	80
Cosmonice Filter	80
Cosmospin Filter	80
Labeling Reagents	82
3. Column Care Products	85
Cleaning Solution Kit for Reversed Phase HPLC Columns	85
Storage Solution for Reversed Phase HPLC Columns	86
4. COSMOSIL HPLC Accessories	87

V. Applications

1. COSMOSIL Applications	90
2. Applications of Drug Substances in the Japanese Pharmacopeia, 15th	91
3. COSMOSIL Application	92
(1) Drugs	92
(2) Crude Drugs	125
(3) Natural Compounds	130
(4) Pesticides	133
(5) Food Additives	135
(6) Vitamins	137
(7) Metabolites	140
(8) Carbohydrates	142
(9) Lipids	145
(10) Nucleic Acid Related Substances	147
(11) Amino Acids, Peptides and Proteins	149
(12) The Others	156
4. Reference List	163

VI. Technical Notes

1. FAQ and Troubleshooting	166
(1) FAQ and Troubleshooting List	166
(2) FAQ	167
(3) Troubleshooting	174
2. Liquid Chromatography Basics	182
(Technical Information)	
1. Preparation of Mobile Phase for HPLC	187
2. Inner Diameter of Column (scale down and scale up)	189
3. Troubleshooting for Increased Pressure	191
4. Sample Pretreatment for HPLC	193
5. Baseline Noise in Gradient Elution	198
6. Effect of Guard Column	199
7. Selectivity of Packing Materials in Reversed Phase Liquid Chromatography ..	201
8. Methods in Developing Mobile Phase Condition for C ₁₈ Column	208
9. Comparison with Old Type COSMOSIL	213

VII. Index

Sample Name Index	216
Packing Material's Name Index	226

General Information

General Ordering Information

When placing an order with us or making an enquiry, please contact our International Business Development Group or your local distributor. Please clearly identify the product in question when submitting your enquiry. The speed of innovation is accelerating. We always have brand new or improved columns not listed here. There are also many other products Nacalai Tesque can supply. Therefore we urge you to make enquiries.

Product Description and Availability

Please note that the product specifications are subjected to changes and the manufacturing of some product may be stopped. Please consult the table on page 59 for cross-reference information on old products and their newer and better equivalents.

Column Identification

At the end of each section, the COSMOSIL and COSMOGEL packed columns are listed in a way that the particle size, stationary phase, column size of the packing material can be easily determined.

38019-81 COSMOSIL 5 C₁₈-MS-II 4.6 mm I.D. x 150 mm
(1) (2) (3) (4) (5)

When placing an order, please clearly indicate the product number (1), product name (2), particle size (3), type of stationary phase (4) and column size (5).

Warranty Claims

The manufacturer will replace defective columns if notified within 2 weeks of receipt of the product by the customer under the following conditions:

- 1) Column abnormalities are due to accidents in shipping or rough handling.
- 2) The number of effective plates of the column is considerably lower than the minimum guaranteed theoretical plate number documented in the inspection report that accompanies each column.

Please contact the International Business Development Section of Nacalai Tesque (info.intl@nacalai.com) or your local distributor for additional information.

Terms and Conditions of Sale

Terms are subject to conditions set forth by the authorized Nacalai Tesque distributors in each country.

Not for Clinical Use

Nacalai Tesque products are not intended for clinical use. While clinical applications may be shown, these products are not validated for clinical use.

1. COSMOSIL/COSMOGEL HPLC Columns.....	6
2. Column Selection Guide.....	7
3. COSMOSIL Silica Packing Material	8
4. Performance Guarantee	10
(1) Quality Guarantee of Packing Materials.....	10
(2) Quality Guarantee of COSMOSIL Packed Columns	11
5. Reversed Phase Chromatography Columns	12
(1) C ₁₈ (ODS) Series	12
COSMOSIL C ₁₈ -MS-II	14
COSMOSIL C ₁₈ -AR-II.....	16
COSMOSIL C ₁₈ -PAQ.....	18
(2) Special Columns	20
COSMOSIL Cholester.....	21
COSMOSIL πNAP	24
COSMOSIL PYE.....	26
COSMOSIL NPE.....	28
COSMOSIL PBB-R.....	29
(3) Other Reversed Phase HPLC Columns.....	30
COSMOSIL CN-MS	31
COSMOSIL C ₂₂ -AR-II, C ₈ -MS, C ₄ -MS, TMS-MS, PE-MS	32
(4) Silica Based Preparative Columns	33
COSMOSIL 15C ₁₈ -MS-II, 15C ₁₈ -AR-II, 15C ₁₈ -PAQ.....	33
6. Normal Phase Chromatography Column.....	34
COSMOSIL SL-II	34
7. Hydrophilic Interaction Chromatography Column.....	36
COSMOSIL HILIC.....	36
8. Mono- and Oligosaccharide Analysis Columns	38
COSMOSIL Sugar-D.....	39
COSMOSIL NH ₂ -MS	41
9. Protein Separation Columns.....	42
(1) Reversed Phase Chromatography.....	42
COSMOSIL Protein-R.....	42
COSMOSIL C ₁₈ -AR-300, C ₈ -AR-300, C ₄ -AR-300, Ph-AR-300	44
(2) Gel Filtration Chromatography Column(aqueous).....	46
COSMOSIL Diol-120-II, Diol-300-II.....	46
(3) Ion Exchange Chromatography Column	48
COSMOGEL IEX Series	48
(4) Hydrophobic Interaction Chromatography Column	51
COSMOSIL HIC.....	51
10. Columns for Fullerene Separation.....	52
COSMOSIL Buckyprep	54
COSMOSIL Buckyprep-M.....	55
COSMOSIL PBB.....	56
COSMOSIL NPE.....	57
COSMOSIL PYE.....	57
11. Columns for Soluble Carbon Nanotube Separation.....	58
COSMOSIL CNT-300, CNT-1000, CNT-2000.....	58
12. Conventional Columns	59

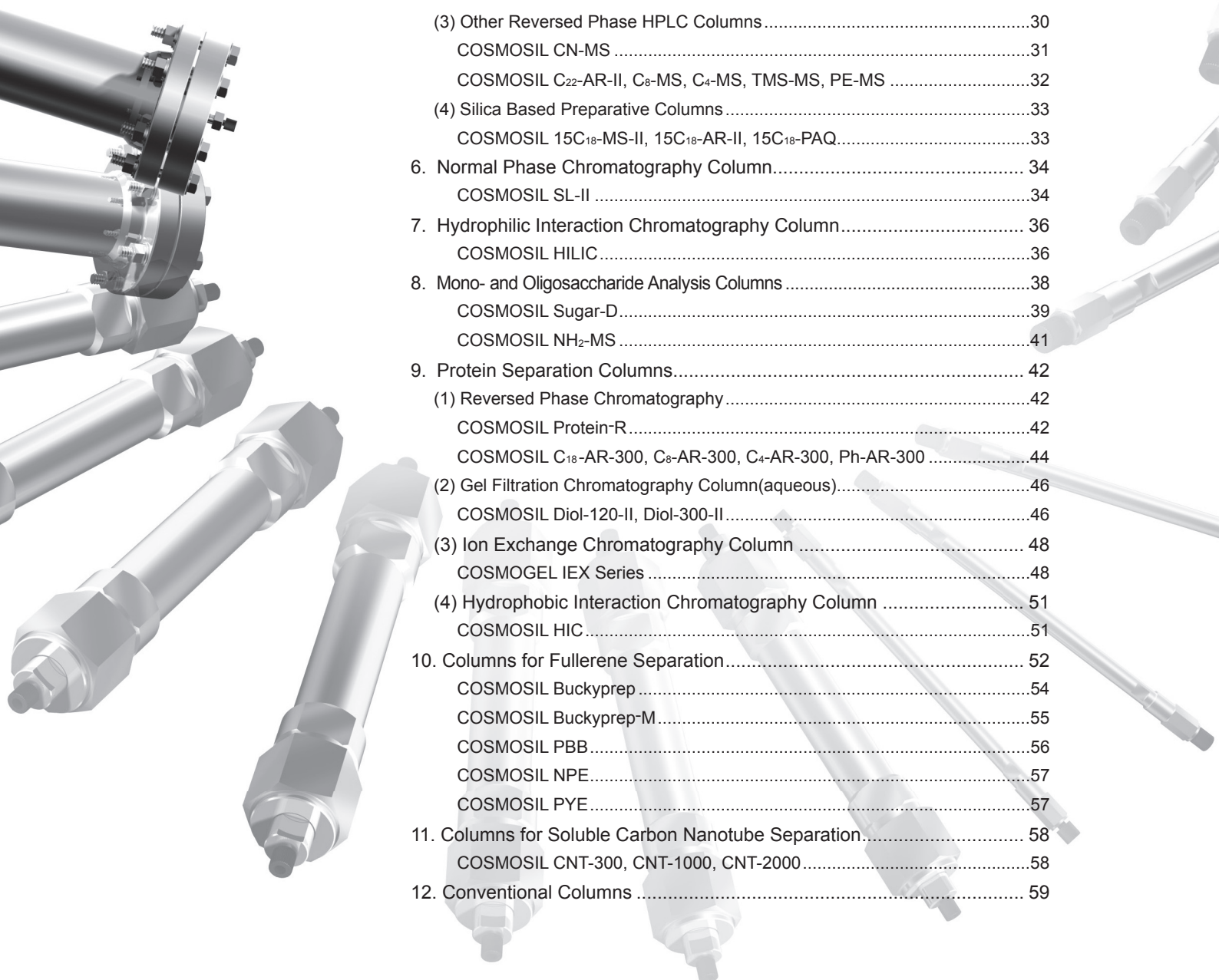

1. COSMOSIL/COSMOGEL HPLC Columns

Sample	Separation Mode	Packing Material	Stationary Phase	Special Features and Applications	USP Category	Page	
Organic Compounds (low M.W.)	Reversed Phase	C ₁₈ -MS-II	Octadecyl Group	Multi-purpose C ₁₈ column. Monofunctional silylation on ultra-pure silica gel for separation of widest range of compounds.	L1	14, 62	
		C ₁₈ -AR-II		Multi-purpose C ₁₈ column using ultra-pure silica gel. Features strong acid resistance and suitable for a wide range of separation.	L1	16	
		C ₁₈ -PAQ		Reversed phase column, compatible with 100% water based mobile phases.	L1	18	
		Cholester	Cholesteryl Group	Usable under the same condition as C ₁₈ . Unique rigid cholesteryl structure improves separation.		21, 62	
		πNAP	Naphthylethyl Group	Stronger π-π interaction than phenyl column		24, 62	
		PYE	Pyrenylethyl Group	The most powerful π-π interaction	Coming soon	26	
		NPE	Nitrophenylethyl Group	Separation utilizing π-π interaction and Dipole-dipole interaction		28	
		PBB-R	Pentabromobenzyl Group	Separation utilizing dispersion force		29	
		CN-MS	Cyanopropyl Group	Great reproducibility using isocratic elution mode	L10	31	
		C ₂₂ -AR-II	Docosyl Group	Alkyl chain columns except C ₁₈ column			32
		C ₈ -MS	Octyl Group		L7		
		C ₄ -MS	Butyl Group		L26		
		TMS-MS	Trimethyl Group		L13		
		PE-MS	Phenylethyl Group	π-π interaction	L11		
		Normal Phase	SL-II	--	Normal phase chromatography with non-polar organic solvents	L3	34
Hydrophilic Interaction	HILIC	Triazole	Retains highly polar compounds that would not be retained in C ₁₈ column		36		
Mono- and Oligosaccharides	Hydrophilic Interaction	Sugar-D	Secondary/Tertiary Amine	A novel stationary phase for saccharide separation. Extended column life and increased stability. Alternative to aminopropyl type		39	
		NH ₂ -MS	Aminopropyl Group	Primary amino bonded column		41	
Proteins	Reversed Phase	Protein-R	Octadecyl Group	The most suitable reversed phase column for proteins		42	
		C ₁₈ -AR-300	Octadecyl Group	Wide pore type reversed phase columns with high acid resistance recommended for the separation of proteins, polypeptides, nucleic acids and other large molecules.	L1	44	
		C ₈ -AR-300	Octyl Group		L7		
		C ₄ -AR-300	Butyl Group		L26		
		Ph-AR-300	Pyrenyl Group		L11		
	Gel Permeation	Diol-120-II	Diol Group	Silica-based gel filtration column for high speed separation of proteins and water soluble polymer	L20	46	
		Diol-300-II					
NEW Ion-exchange		IEX Type Q	Trimethylaminopropyl Type	Anion-exchange Type (purification)	48		
		IEX Type Q-N		Anion-exchange Type (ultra-fast analysis, precise analysis)			
		IEX Type S	Sulfopropyl Type	Cation-exchange Type (purification)			
		IEX Type S-N		Cation-exchange Type (ultra-fast analysis, precise analysis)			
		IEX Type M	Trimethylaminopropyl Type/Sulfopropyl Type	Amphoteric ion-exchange Type (purification)			
		IEX Type M-N		Amphoteric ion-exchange Type (precise analysis)			
Hydrophobic Interaction	HIC	--	Hydrophobic interaction chromatography column for protein separation		51		
Fullerenes	--	Buckyprep	Pyrenylpropyl Group	Standard column for fullerenes separation		54	
		Buckyprep-M	Phenothiazinyl Group	Designed to separate metallofullerenes		55	
		PBB	Pentabromobenzyl Group	Designed for the preparative separation of fullerenes using carbon disulphide, o-dichlorobenzene and toluene		56	
		NPE	Nitrophenylethyl Group	Separation of derivatized fullerenes		57	
		PYE	Pyrenylethyl Group	Separation of fullerenes and structural isomers			
Carbon Nanotubes	Gel Permeation	CNT-300	Hydrophilic Group (neutral)	Separation of soluble carbon nanotubes		58	
		CNT-1000					
		CNT-2000					

For old type columns, please refer to page 59.

2. Column Selection Guide

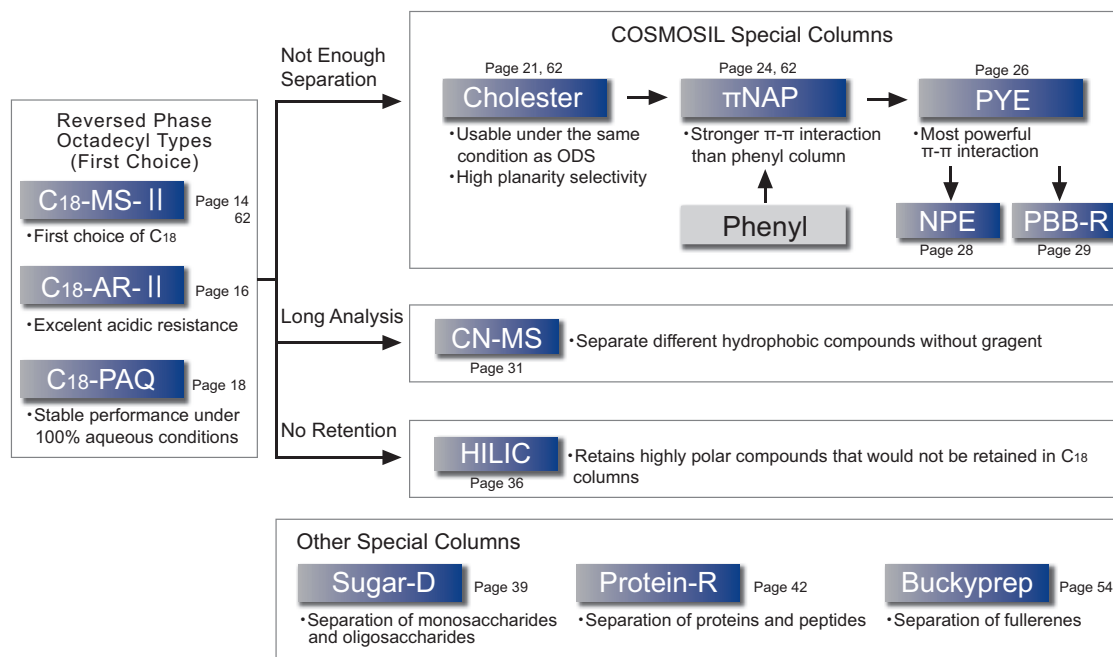

COSMOSIL Columns Selection Guide

Organic Compounds (low M.W.)

Octadecyl group bonded column (C₁₈, ODS) are recommended as first-choice columns for separations of organic compounds (low M.W.). If there is not enough separation or no retention using COSMOSIL C₁₈ columns, COSMOSIL series offer many kinds of specialty columns.

- Medicines
- Crude drugs
- Natural compounds
- Pesticides
- Food additives
- Vitamins
- Lipids etc.

Saccharides

- COSMOSIL Sugar-D is recommended for the separation of monosaccharides and oligosaccharides as a first-choice column.
- For the separation of sugar derivatives, COSMOSIL C₁₈-PAQ is suitable as well.

Proteins

- Please select based on the separation mode. Please refer to page 42.

Fullerenes

- COSMOSIL Buckyprep is most suitable for the separation of fullerenes.

3. COSMOSIL Silica Packing Material

Introduction

Superior HPLC columns can be produced only with excellent packing materials and superb packing technique. COSMOSIL columns are well known for their high efficiency and high-resolution separations. Based on spherical, totally porous silica, COSMOSIL columns provide enhanced chemical and mechanical stability as well as very high surface coverage.

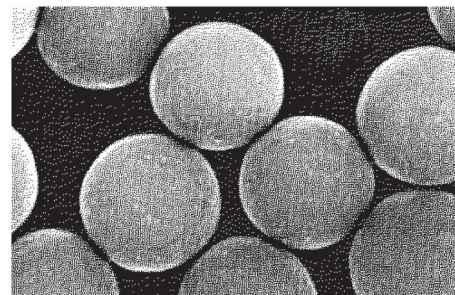
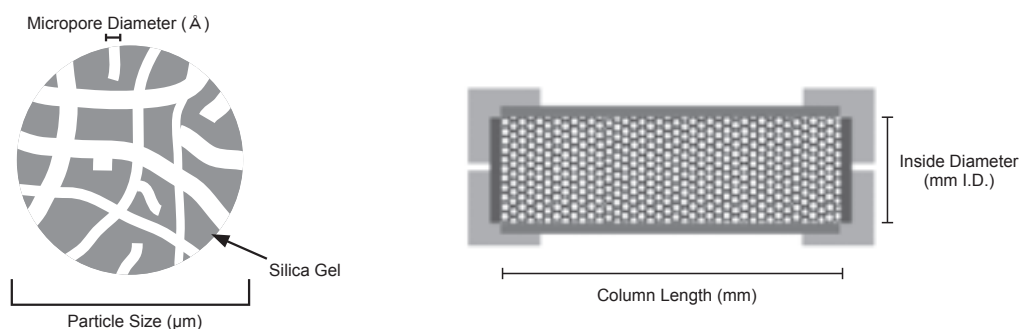

Figure. Microscopic photograph of the silica gel

Packing Material and View Showing a Frame Format of Column



Raw Material Silica Gel

COSMOSIL is based on ultra pure porous spherical silica gel (purity: 99.99% or higher). Low-purity silica gel contains metal impurity which may cause interference in the separation, especially for metal coordination compounds.

Effect of Metal Impurities

Column size: 4.6mm I.D.-150mm
 Mobile phase: Acetonitrile/ H₂O = 50/50
 Flow rate: 1.0 ml/min
 Temperature: 30°C
 Detection: UV254nm

Sample: Paeonol

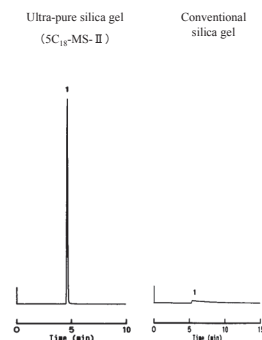

Metal Coordination Compounds

The compounds, which have 2 or more -OH group, -COOH group, -C=O, -NH₂ group in the adjacent positions, can complex with metal impurity, which results in peak tailing.

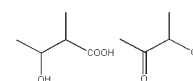

Table. Metal content percentage (ppm)

Packing Material	Metal Content (ppm)						Total
	Al	Ca	Fe	Mg	Na	Ti	
Ultra Pure Silica Gel	4	10	11	3	12	<1	41
Normal Silica Gel	32	450	26	88	56	134	786

Stationary Phase Construction

While C₁₈ columns are most widely used in reversed phase HPLC, it is important to distinguish between two very different bonded phase formats. Monomeric type C₁₈ format incorporates the bonding of the C₁₈ alkyl chain to a single silica atom on the silica gel backbone. Monomeric type columns such as the COSMOSIL C₁₈-MS-II and the MS series have excellent synthesis reproducibility, very good lot-to-lot reproducibility and short mobile phase equilibration times. On the other hand, the polymeric C₁₈ format incorporates a tri-functional silylation procedure whereby the octadecyl group is bonded to 2 or 3 silica atoms on the silica gel backbone. This increases silylation results in far greater column stability particularly in acidic mobile phase conditions.

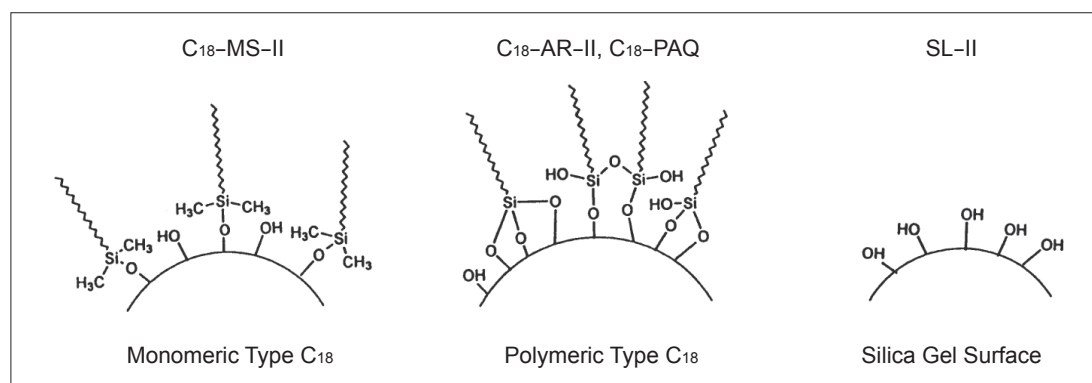
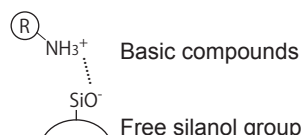

Figure. Diagrams of different stationary phase constructions (before end-capping treatment)

End-capping Treatment

The silanols (Si-OH groups) on the silica surface provided bonding site for stationary phases. However, part of the silanol groups remain un-capped as residual silanol groups even after the end-capping treatment, they cause peak tailing for basic compounds. COSMOSIL packing materials for reversed phase chromatography are of near-perfectly end-capped residual silanol groups.



Basic compound can form ionic bonds with residual free silanols. The ionic bonding causes peak tailing of basic compounds if a silicabased column is not perfectly end-capped.

Effect of Residual Silanol

Column size: 4.6mm I.D.-150mm
Mobile phase: Methanol/ 20mmol/l Phosphate buffer (pH7) = 20/80
Flow rate: 1.0 ml/min
Temperature: 30°C
Detection: UV254nm

Sample: 1; Uracil
2; *N*-Methylbenzylamine
3; *N,N*-Dimethylbenzylamine
4; Benzyl Alcohol

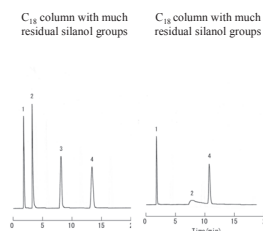
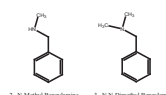

Synthesis Reproducibility

By using strictly selected silica gel and constant synthesis conditions, the chemically bonded type column retains a variance of the capacity factor (k') between synthetic lots of within $\pm 10\%$ and a variance of the separation factor (α) of within $\pm 5\%$. The figures below show in graphic form the lot inspection results of synthesized packing material (COSMOSIL 5C₁₈-MS-II). Figure 1 shows the variance of stationary phase (octadecyl group) introduced volume which is the basic indicator of the quality of the packing material. Figure 2 shows the end-capping efficiency of the packing material. The variance among the lots is reduced to the minimum in the COSMOSIL packed columns.

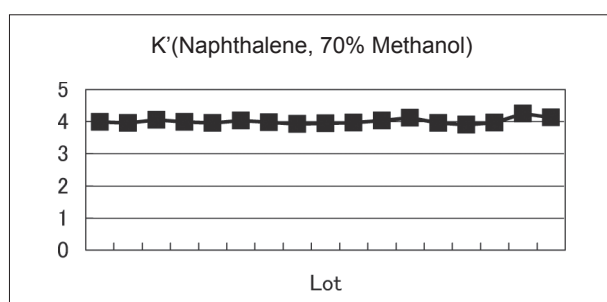

Figure 1. Variance of the combining volume between silica gel and C₁₈

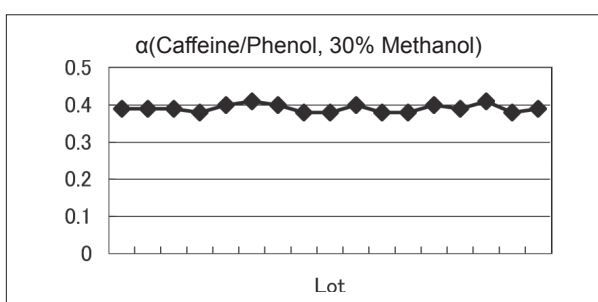

Figure 2. Variance of end capping efficiency of the packing material

4. Performance Guarantee

(1) Quality Guarantee of Packing Materials

Introduction

The strict quality control system of Nacalai Tesque supports the customers with an individual "Inspection Report" which accompanies each and every COSMOSIL and COSMOGEL Packed Column (except guard columns) and an additional "Certificate of Analysis" for the COSMOSIL 5C₁₈-MS-II and 5C₁₈-AR-II (4.6 mm I.D. x 150 mm and 4.6 mm I.D. x 250 mm).

Validated Columns

Product Name	Product Number	Column Size
COSMOSIL 5C ₁₈ -MS-II	38019-81	4.6 mm I.D. x 150 mm
	38020-41	4.6 mm I.D. x 250 mm
COSMOSIL 5C ₁₈ -AR-II	38144-31	4.6 mm I.D. x 150 mm
	38145-21	4.6 mm I.D. x 250 mm
COSMOSIL Cholester	05976-61	4.6 mm I.D. x 150 mm
	05977-51	4.6 mm I.D. x 250 mm
COSMOSIL HILIC	07056-51	4.6 mm I.D. x 150 mm
	07057-41	4.6 mm I.D. x 250 mm

COSMOSIL Certificate of Analysis

Validate terms of the physical properties of the silica gel, the carbon content, polar selectivity, hydrophobicity, silanol capacity, steric selectivity, inactive degree to basic and chelating compounds.

E.g.,) Certificate of Analysis (5C₁₈-MS-II)

Certificate of Analysis			MS-II
COSMOSIL 5C ₁₈ -MS-II		GEL Lot No.	29
Base silicagel material	Specification	Results	
Median Particle Size			
50% cum vol [μm]	4.3-4.6	4.5	
Surface Area [m ² /g]	320-350	321	
Pore Volume [ml/g]	0.9-1.1	0.9	
Median Pore Diameter [nm]	11.0-13.0	11.8	
Carbon content [%]	15.5-17.5	15.6	
Atomic Emission [ppm]			
Al	≤5	1.5	
Fe	≤20	8.3	
Ti	≤0.5	0.1	
Na	≤20	1.7	
Chromatographic Results			
TEST A			
α[k (Methyl Benzoate)/k (Benzene)]	≤0.80	0.73	
α[k (Toluene)/k (Benzene)]	≥1.60	1.76	
TEST B			
α[k (Caffeine)/k (Phenol)]	≤0.44	0.40	
TEST C			
α[k (N-Acetyl Procainamide) /k (Benzyl Alcohol)]	≤0.60	0.6	
α[N(N'-Acetyl Procainamide) /N(Benzyl Alcohol)]	≥0.30	0.38	
TEST D			
α[k (8-Quinolol) /k (Propylbenzene)]	≤0.14	0.09	
α[N(8-Quinolol) /N(Propylbenzene)]	≥0.15	0.17	
Nacalai Tesque Inc. Kyoto, Japan			
Approved : Quality Control Dept.			
Name: <i>R. Swaguchi</i>	Date: 2009.8.21	00-3	

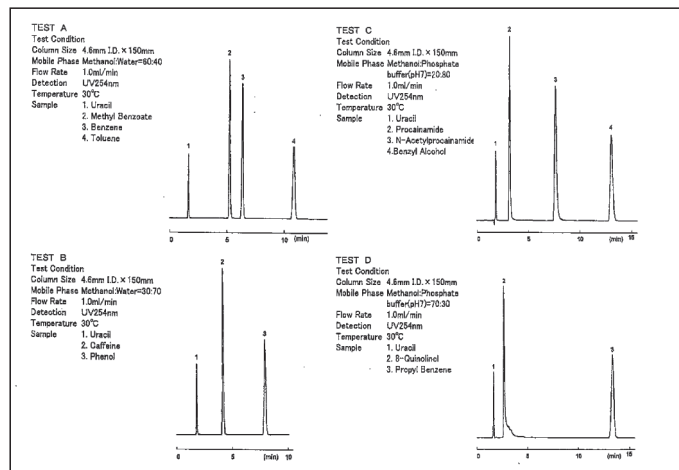

Available in 3 Lots

3 different lots of packing materials are available to demonstrate high reproducibility. Please contact us for more information. (info.intl@nacalai.com)

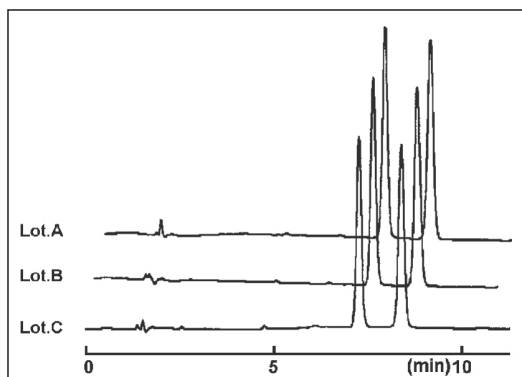

(2) Quality Guarantee of COSMOSIL Packed Columns

“Inspection Report” is attached to every COSMOSIL Column to guarantee high quality. Please use our strictly controlled products with confidence.

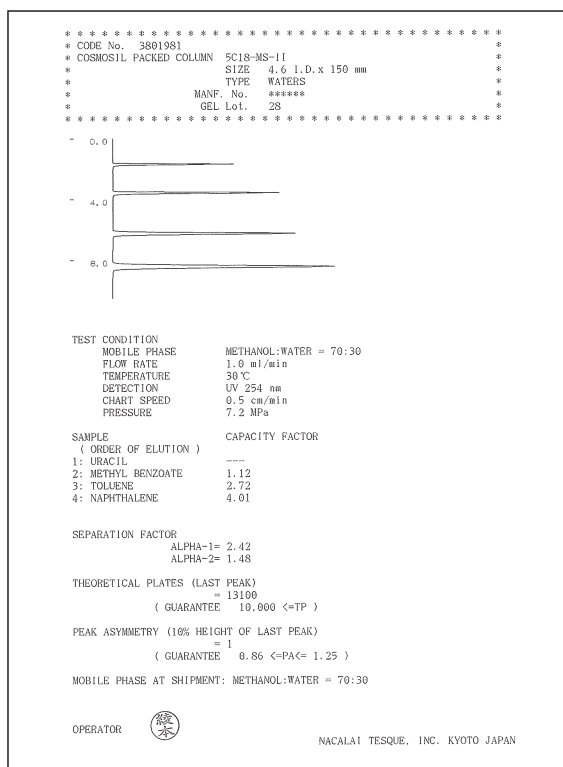

Sample of Inspection Report

Inspection Items

- Theoretical plate number
- Peak asymmetry
- Capacity factor
- Separation factor
- Pressure

5. Reversed Phase Chromatography Columns

(1) C₁₈ (ODS) Series

Introduction

The reversed phase HPLC column is most commonly used because of the high theoretical plate number, excellent separation characteristics, reproducibility, affordable cost and ease of use. Columns packed with the octadecyl group bonded type silica gel (C₁₈, ODS) are the most widely employed. We offer three types of octadecyl group bonded columns: COSMOSIL C₁₈-MS-II, C₁₈-AR-II and C₁₈-PAQ, each of which has a different separation property.

Specifications

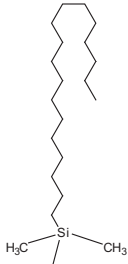
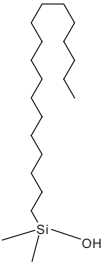
Packing Material	C ₁₈ -MS-II	C ₁₈ -AR-II	C ₁₈ -PAQ
Silica Gel	High Purity Porous Spherical Silica		
Average Particle Size	3, 15µm*	3, 5, 15 µm	5, 15 µm
Average Pore Size	approx. 120 Å		
Specific Surface Area	approx. 300 m ² /g		
Bonded Phase Structure			
Bonded Phase	Octadecyl Group		
Bonding Type	Monomeric	Polymeric	
Main Interaction	Hydrophobic Interaction		
End-capping Treatment	Near-perfect Treatment		
Carbon Load	approx. 16%	approx. 11%	approx. 11%
Usable pH Range	2~10**	1.5~7.5**	2~7.5
Features	<ul style="list-style-type: none"> • Multi-purpose C₁₈ Column • Suitable for basic compounds 	<ul style="list-style-type: none"> • Features strong acid resistance • Suitable for acid compounds and peptides 	<ul style="list-style-type: none"> • Suitable for hydrophilic compounds. • Compatible with 100% water based mobile phase.

* For 2.5C₁₈-MS-II (2.5 µm), please refer to page 62.

**Optimal pH range of silica-based columns is between 2 and 7.5. Extreme pH may significantly decrease column lifetime.

Difference of Separation Property

Comparing to COSMOSIL 5C₁₈-MS-II;

COSMOSIL 5C₁₈-AR-II retains planar structure compounds (Sample 6) longer. COSMOSIL 5C₁₈-PAQ has shorter retention time, and retains polar compounds (Sample 1,2) longer.

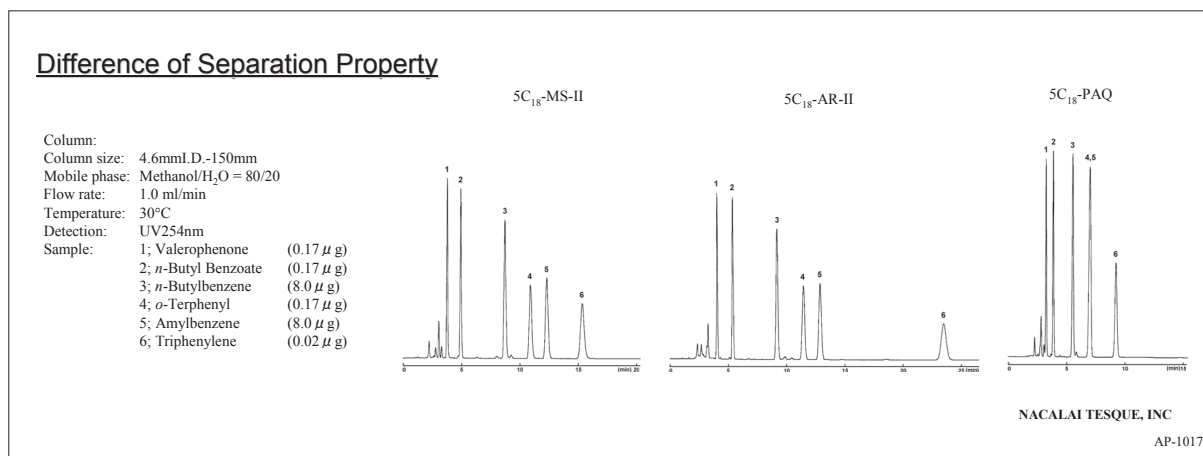

Column Selection Based on Applications

We prepare the following application data to help you select separation conditions.

COSMOSIL Application

COSMOSIL Application has more than 7,000 applications using COSMOSIL columns. Setting optimal HPLC experimental parameters is the one of the most important processes that requires experience and time. COSMOSIL Application provides you with sample analysis conditions with widely used ODS columns and other specialty columns. For more information, please visit COSMOSIL Application page on our website at <http://www.nacalai.co.jp/global/cosmosil/>. For more information, please see page 90.

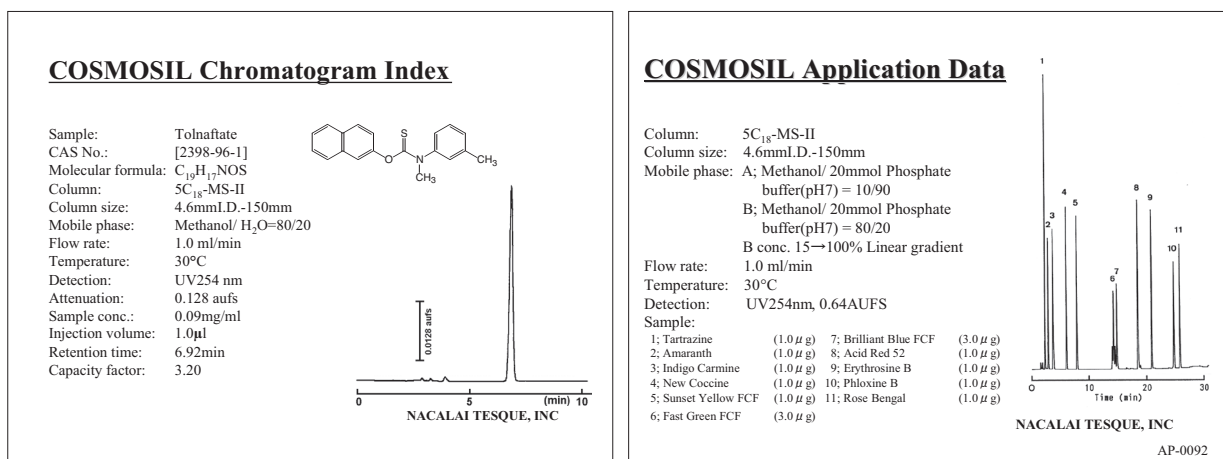

Applications of Drug Substances in the Japanese Pharmacopoeia, 15th

We have prepared drug analysis HPLC data using three different COSMOSIL C₁₈ columns as specified in Japanese Pharmacopoeia, 15th version. 5µm silica gel column size 4.6mm I.D. x 150 mm or 250 mm were used with reagent grade samples. Furthermore, we analyzed reference drug substances with internal standard and impurities. The data are available at our web site at <http://www.nacalai.co.jp/global/cosmosil/>, or search "COSMOSIL Japanese Pharmacopoeia" on the web. An example of the application is shown after page 91.

Column Selection by Mobile Phase

- If a mobile phase is determined, use the following chart to select an appropriate COSMOSIL column.
- Refer to application above for choosing a mobile phase of new analysis.
- Adjustment of pH is required for dissociative compounds.
- Generally acidic mobile phase is suitable for acidic compounds, and neutral mobile phase is suitable for basic compounds.
- If you are not sure about the mobile phase, try C₁₈-MS-II first.

Column Selection Guide by Mobile Phase

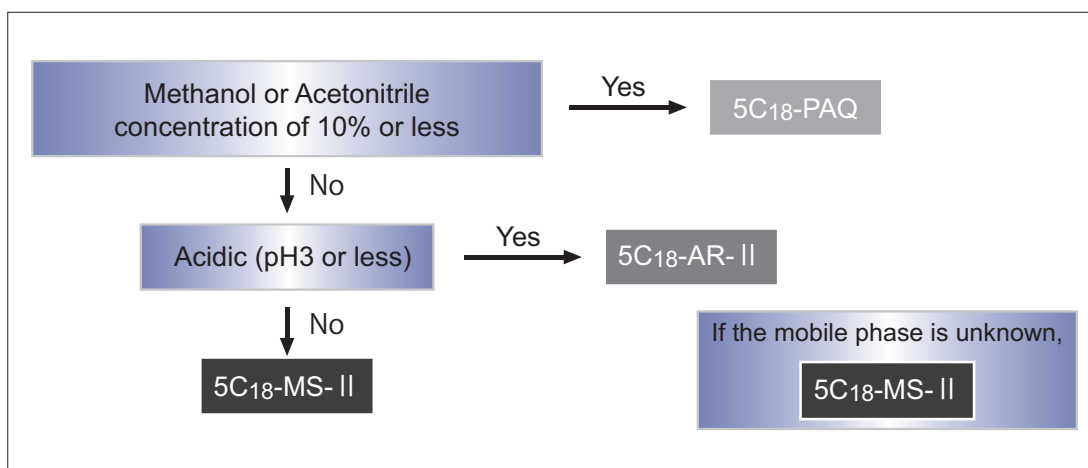

COSMOSIL C₁₈-MS-II

- Multi-purpose C₁₈ Column
- High reproducibility
- A wide range of applications

Separation Property

The COSMOSIL 5C₁₈-MS-II is a well-balanced column with better basic performance such as sharper peaks of basic compounds and chelating compounds, large hydrophobic interaction, low analytical pressure, and high theoretical plate number. The COSMOSIL 5C₁₈-MS-II is first-choice column for reversed phase chromatography.

Separation Property

Column: 5C₁₈-MS-II
Column size: 4.6mm I.D.-150mm
Mobile phase: Methanol/ H₂O = 60/40
Flow rate: 1.0 ml/min
Temperature: 30°C
Detection: UV254nm

Sample: 1; Acetophenone (0.05 μg)
2; Methyl Benzoate (0.5 μg)
3; Benzene (2.0 μg)
4; Toluene (2.0 μg)

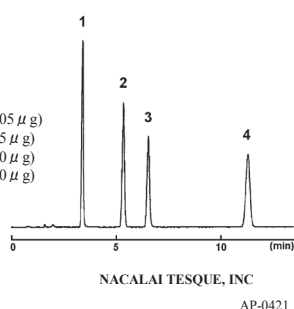

Table. Comparison of hydrophobic interaction, analytical pressure, and theoretical plate number

Column	Hydrophobic Interaction α (Toluene/Benzene)	Pressure (MPa)	Theoretical Plate Number (Toluene)
COSMOSIL 5C ₁₈ -MS-II	1.96	8.3	14300
A Company C ₁₈	1.99	13.0	16800
B Company C ₁₈	1.94	8.0	14000
C Company C ₁₈	1.69	11.2	5600
D Company C ₁₈	1.84	10.5	14200

Analysis of Basic Compounds and Metal Coordination Compounds

The COSMOSIL 5C₁₈-MS-II column, taking advantage of a new end-capping treatment, can replace the original COSMOSIL C₁₈ (ODS) column. A new end-capping treatment with polar groups for "shield effect" has significantly improved peak shape for basic compounds. Ultra pure silica gel with low trace-metal content is used for COSMOSIL columns; thus the columns provide excellent peak shapes for chelating compounds.

Basic Compounds

Column: 5C₁₈-MS-II
Column size: 4.6mm I.D.-150mm
Mobile phase: Methanol/ 20mmol/l Phosphate buffer (pH7) = 20/80
Flow rate: 1.0 ml/min
Temperature: 30°C
Detection: UV254nm

Sample: 1; Procainamide (0.38 μg)
2; N-Acetylprocainamide (0.25 μg)
3; Benzylalcohol (5.63 μg)

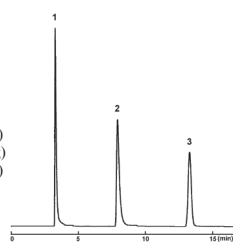

Metal Coordination Compounds

Column: 5C₁₈-MS-II
Column size: 4.6mm I.D.-150mm
Mobile phase: Acetonitrile / 20mmol/l Phosphoric Acid = 5/95
Flow rate: 1.0 ml/min
Temperature: 30°C
Detection: UV240nm

Sample: Oxine-copper

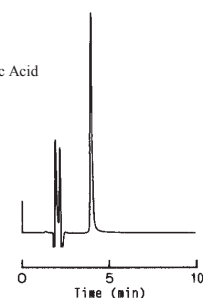

High Reproducibility

The strict quality control system of Nacalai Tesque supports the customers with an individual "Inspection Report" which accompanies each and every COSMOSIL and COSMOGEL Packed Column (except guard columns) and an additional "Certificate of Analysis" for the COSMOSIL 5C₁₈-MS-II (4.6 mm I.D. x 150 mm and 4.6 mm I.D. x 250 mm). For more informations, please refer to page 10.

A Wide Range of Applications

A wide selection of applications, e.g. drug molecules, is available to achieve appropriate separation parameters for target samples.

● Parasympatholytic Agents

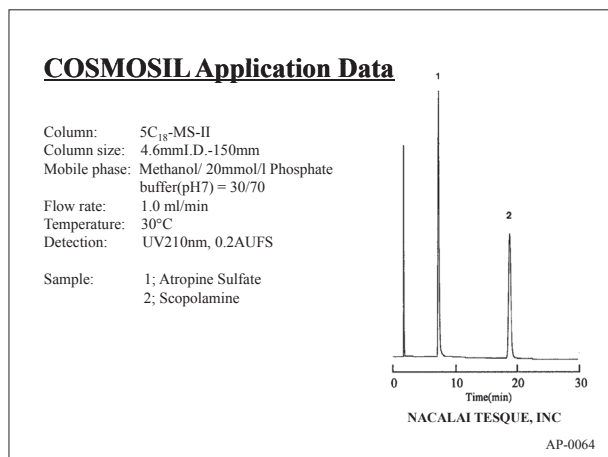

● Analgesic Antipyretic Drugs

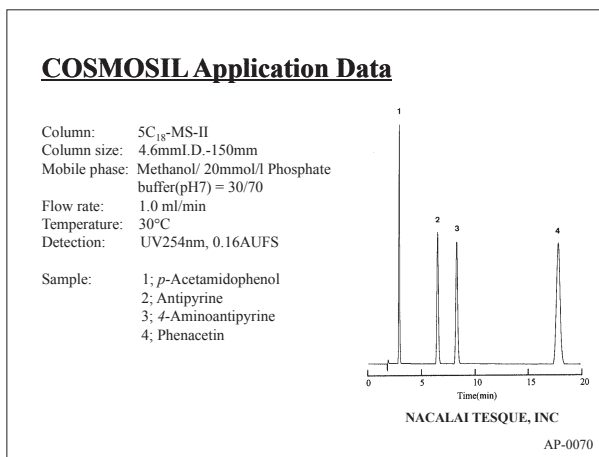

Ordering Information

● Analytical / Preparative Column (Particle Size: 5 μm)

COSMOSIL 5C₁₈-MS-II Packed Column

Column Size I.D. x Length (mm)	Product Number	Column Size I.D. x Length (mm)	Product Number
1.0 x 50	02824-31	4.6 x 100	38018-91
1.0 x 150	02896-01	4.6 x 150	38019-81
2.0 x 30	05876-71	4.6 x 150 3 lots set*	09397-73
2.0 x 50	04355-21	4.6 x 250	38020-41
2.0 x 100	05597-31	6.0 x 150	38021-31
2.0 x 150	38025-91	6.0 x 250	38022-21
2.0 x 250	05761-61	10 x 50	05789-21
3.0 x 100	05458-51	10 x 150	34355-91
3.0 x 150	34245-31	10 x 250	38023-11
3.0 x 250	34254-11	20 x 150	05091-41
4.6 x 30	34341-61	20 x 250	38024-01
4.6 x 50	38017-01	28 x 250	05760-71

COSMOSIL 5C₁₈-MS-II Guard Column

Column Size I.D. x Length (mm)	Product Number
4.6 x 10	38014-31
4.6 x 10 Cartridge**	38015-89
10 x 20	38016-11
20 x 20	05790-81
20 x 50	34371-71
28 x 50	34347-01

* For 4.6 x 150 3 lots set, please refer to page 11.
 ** 3 cartridges included, needs a holder, refer to page 87.

● Preparative Column (Particle Size: 15 μm)

COSMOSIL 15C₁₈-MS-II Packed Column

Column Size I.D. x Length (mm)	Product Number
28 x 250	34525-61
50 x 250	05886-41
50 x 500	34531-71

COSMOSIL 15C₁₈-MS-II Guard Column

Column Size I.D. x Length (mm)	Product Number
28 x 50	05885-51
50 x 50	34527-41

● Fast LC Column (Particle Size: 3 μm)

COSMOSIL 3C₁₈-MS-II Packed Column

Column Size I.D. x Length (mm)	Product Number
2.0 x 50	05514-01
4.6 x 10	38065-71
4.6 x 50	38066-61
4.6 x 100	38067-51

For more information, please refer to page 33 for 15C₁₈-MS-II (15 μm) and page 62 for 2.5C₁₈-MS-II (2.5 μm).
 For flow rate and equipment of semi-micro columns, or scale up to preparative columns, please refer to page 189.
 For 5C₁₈, 5C₁₈-MS, please refer to page 59.

COSMOSIL C₁₈-AR-II

- Features strong acid resistance
- Suitable for acid compounds and peptides

Acid Resistance

The COSMOSIL 5C₁₈-AR-II packed column features a polymeric type of C₁₈ reversed phase material. The acidic resistance of COSMOSIL 5C₁₈-AR-II is much improved compared with commercially available monomeric type octadecyl stationary phases. It retains high performance even in case of acidic mobile phases commonly used to separate acidic compounds and peptides.

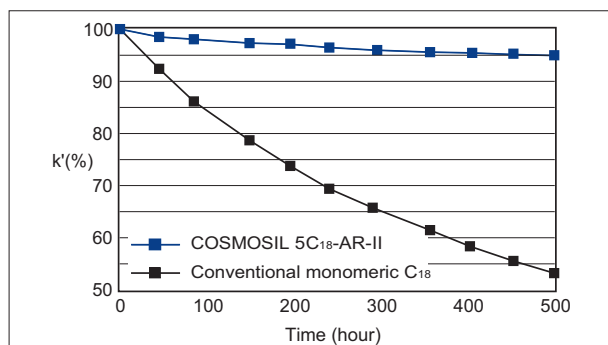
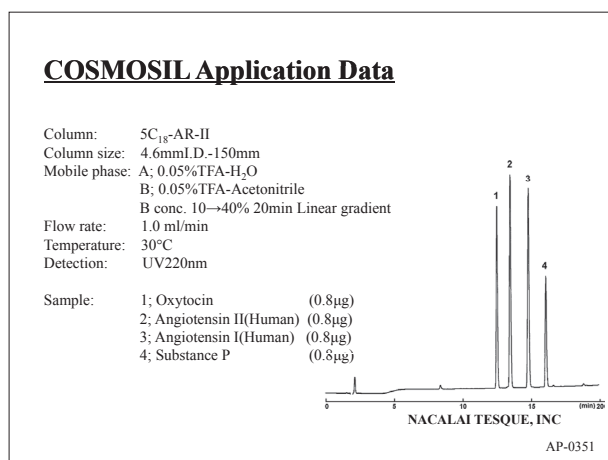

Figure.
Decomposition test in 0.1% Trifluoroacetic acid solution at 60°C.
Capacity factor (k') = Naphthalene,
Mobile phase: Methanol / H₂O=70/30

Applications

• Peptides



• Organic Acids

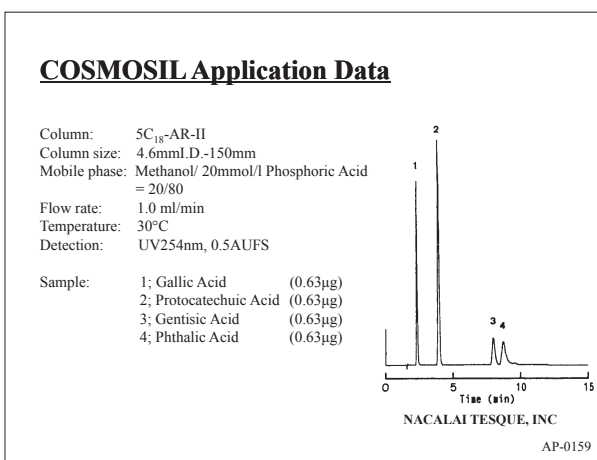

• Salicylic Acid Esters

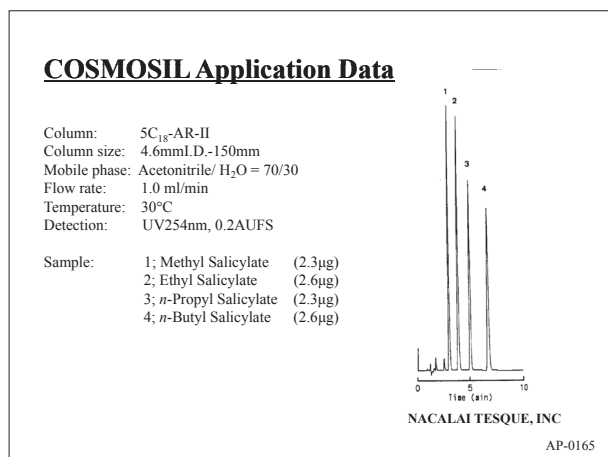

• Parabens

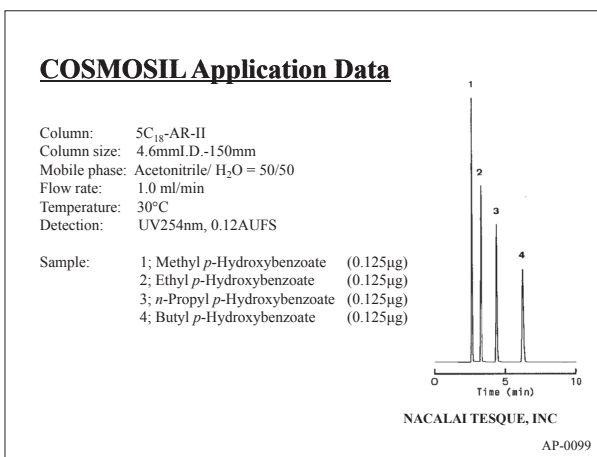

LC/MS Applications

- Identification of herbal medicine constituents by LC/MS

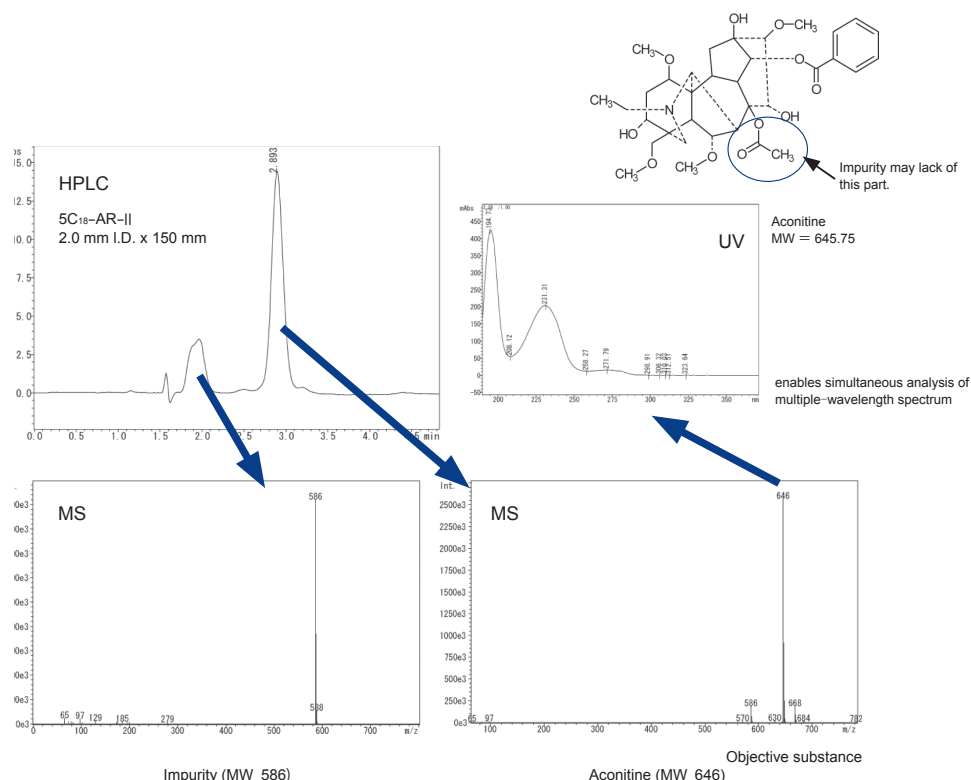

Ordering Information

- Analytical / Preparative Column (Particle Size: 5 μ m)

COSMOSIL 5C₁₈-AR-II Packed Column

Column Size I.D. x Length (mm)	Product Number	Column Size I.D. x Length (mm)	Product Number
1.0 x 50	02955-21	4.6 x 100	38143-41
1.0 x 150	02951-61	4.6 x 150	38144-31
2.0 x 30	05098-71	4.6 x 150 3 lots set*	09396-83
2.0 x 50	34400-81	4.6 x 250	38145-21
2.0 x 100	34469-11	6.0 x 150	38146-11
2.0 x 150	37992-51	6.0 x 250	38147-01
2.0 x 250	05272-71	10 x 50	05369-21
3.0 x 100	05791-71	10 x 150	34350-41
3.0 x 150	38028-61	10 x 250	38149-81
3.0 x 250	38029-51	20 x 150	34316-01
4.6 x 30	05877-61	20 x 250	38150-41
4.6 x 50	38142-51	28 x 250	34362-91

COSMOSIL 5C₁₈-AR-II Guard Column

Column Size I.D. x Length (mm)	Product Number
4.6 x 10	38141-61
4.6 x 10 Cartridge**	38008-89
10 x 20	38148-91
20 x 20	34458-51
20 x 50	34479-81
28 x 50	34363-81

*For 4.6 x 150 3 lots set, please refer to page 11.
**3 cartridges included, needs a holder, refer to page 87.

- Preparative Column (Particle Size: 15 μ m)

COSMOSIL 15C₁₈-AR-II Packed Column

Column Size I.D. x Length (mm)	Product Number
28 x 250	37978-51
50 x 250	38058-71
50 x 500	05884-61

COSMOSIL 15C₁₈-AR-II Guard Column

Column Size I.D. x Length (mm)	Product Number
28 x 50	38030-11
50 x 50	38057-81

COSMOSIL 3C₁₈-AR-II Packed Column

Column Size I.D. x Length (mm)	Product Number
2.0 x 50	05478-91
4.6 x 10	38068-41
4.6 x 50	38069-31
4.6 x 100	38070-91

For 15C₁₈-AR-II, please refer to page 33.
For flow rate and equipment of semi-micro columns, or scale up to preparative columns, please refer to page 189.
For 5C₁₈, 5C₁₈-AR, please refer to page 59.

COSMOSIL C₁₈-PAQ

- Compatible with 100% water based mobile phase
- Suitable for hydrophilic compounds

Stable Performance

Stable performance under 100% aqueous conditions

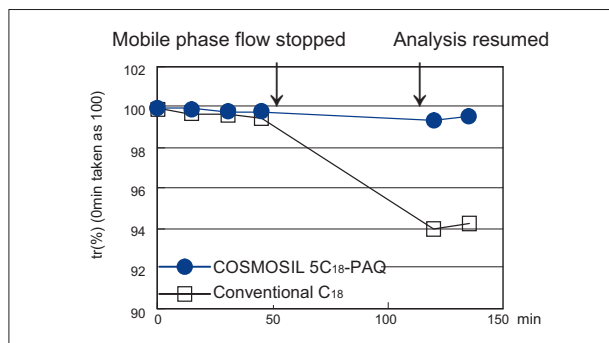

The figure shows the change of retention time for thymine with 100% aqueous mobile phase (20 mmol/l phosphate buffer pH7). The sample was analyzed 4 times (1 hour). Flow of mobile phase was then stopped for 1 hour. The sample was analyzed under the same condition again after 1 hour. The conventional C₁₈ column showed change of retention time, but COSMOSIL 5C₁₈-PAQ maintained stable retention time.

Applications

• Organic Acids

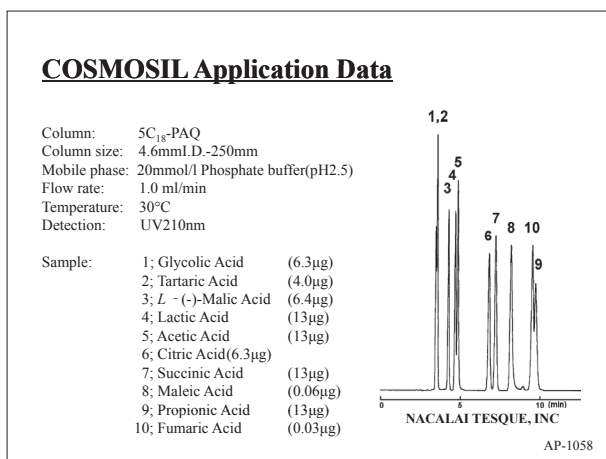

• Nucleobases and Nucleosides

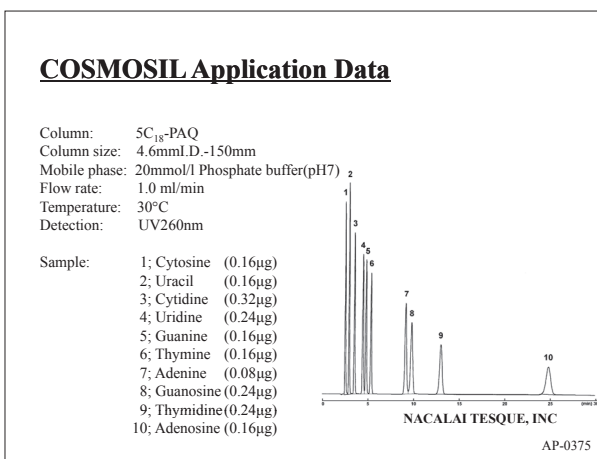

• dNTP

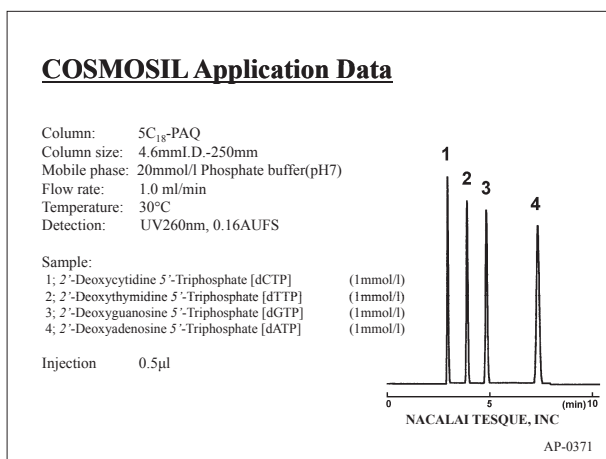

• Catecholamines

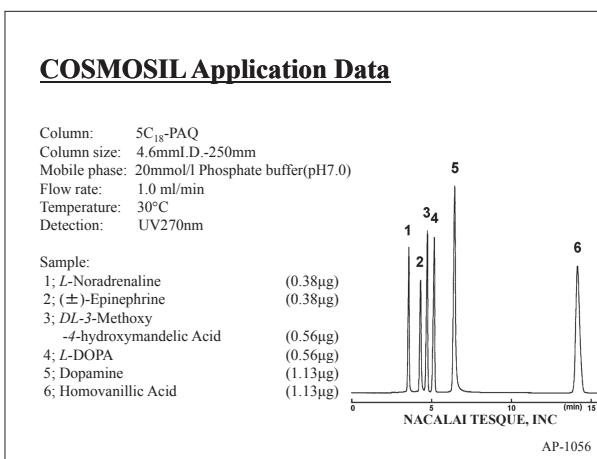

Applications

• Ascorbic Acid

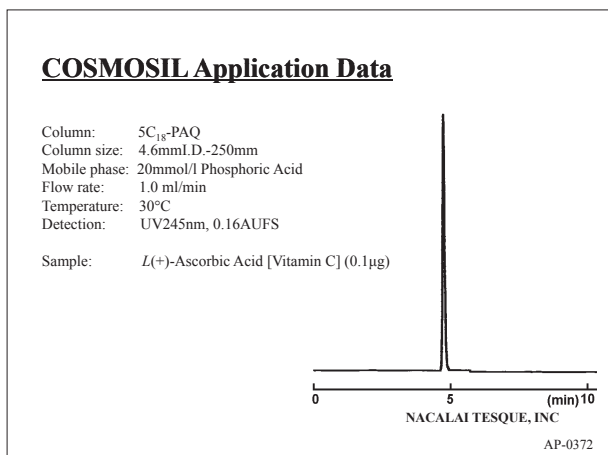

• 2-Phenylethyl glycosides

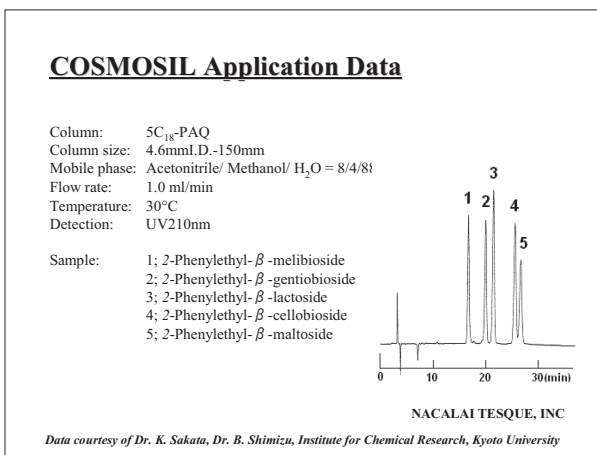

Ordering Information

• Analytical / Preparative Column (Particle Size: 5 µm)

COSMOSIL 5C₁₈-PAQ Packed Column

Column Size I.D. x Length (mm)	Product Number	Column Size I.D. x Length (mm)	Product Number
1.0 x 50	05792-61	4.6 x 100	05799-91
1.0 x 150	05793-51	4.6 x 150	02486-71
2.0 x 30	05878-51	4.6 x 250	02485-81
2.0 x 50	05794-41	6.0 x 150	34419-61
2.0 x 100	05470-71	6.0 x 250	05800-41
2.0 x 150	34449-71	10 x 50	05801-31
2.0 x 250	05795-31	10 x 150	34466-41
3.0 x 100	05796-21	10 x 250	34376-21
3.0 x 150	05797-11	20 x 150	34476-11
3.0 x 250	05798-01	20 x 250	34373-51
4.6 x 30	05879-41	28 x 250	34456-71
4.6 x 50	34451-21		

COSMOSIL 5C₁₈-PAQ Guard Column

Column Size I.D. x Length (mm)	Product Number
4.6 x 10	02484-91
10 x 20	34457-61
20 x 20	05803-11
20 x 50	05804-01
28 x 50	34455-81

• Preparative Column (Particle Size: 15 µm)

COSMOSIL 15C₁₈-PAQ Packed Column

Column Size I.D. x Length (mm)	Product Number
28 x 250	05888-21
50 x 250	05890-71
50 x 500	05891-61

COSMOSIL 15C₁₈-PAQ Guard Column

Column Size I.D. x Length (mm)	Product Number
28 x 50	05887-31
50 x 50	05889-11

For 15C₁₈-PAQ, please refer to page 33.

For flow rate and equipment of semi-micro columns, or scale up to preparative columns, please refer to page 189.

For 5C₁₈-P, please refer to page 59.

(2) Special Columns

Introduction

Reversed phase HPLC columns have been widely used because of their superior resolution, high theoretical plate number and ease of use. Since hydrophobic interaction is the dominant separation mechanism in reversed phase chromatography, conventional stationary phases such as C₁₈ and C₈ do not offer optimum selectivity for compounds with similar hydrophobicity. COSMOSIL offers a broad selection of columns with unique stationary phases for separation of these difficult analytes. These columns offer improved separation of structurally similar compounds that are difficult to analyze with a C₁₈ type column.

Specifications

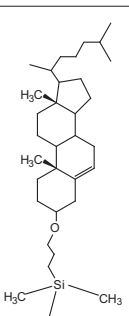
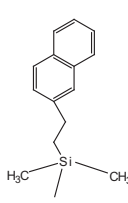
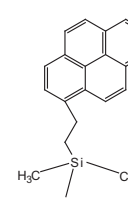
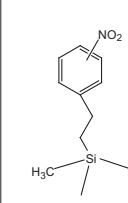
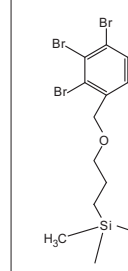
Packing Material	Cholester	πNAP	PYE	NPE	PBB-R
Silica Gel	High Purity Porous Spherical Silica				
Average Particle Size	5 μm*		5 μm		
Average Pore Size	approx. 120 Å				
Specific Surface Area	approx. 300 m ² /g				
Bonded Phase Structure					
Bonded Phase	Cholesteryl Group	Naphthylethyl Group	Pyrenylethyl Group	Nitrophenylethyl Group	Pentabromobenzyl Group
Bonding Type	Monomeric				
Main Interaction	<ul style="list-style-type: none"> Hydrophobic Interaction Molecular Shape Selectivity 	<ul style="list-style-type: none"> Hydrophobic Interaction π-π Interaction 	<ul style="list-style-type: none"> Hydrophobic Interaction π-π Interaction Dispersion Force Charge-transfer Interaction 	<ul style="list-style-type: none"> Hydrophobic Interaction π-π Interaction Dipole-dipole Interaction 	<ul style="list-style-type: none"> Hydrophobic Interaction Dispersion force
End-capping Treatment	Near-perfect Treatment				
Carbon Load	approx. 20%	approx. 11%	approx. 18%	approx. 9%	approx. 8%
Features	<ul style="list-style-type: none"> Usable under condition the same as C₁₈ High molecular sharp selectivity 	<ul style="list-style-type: none"> Stronger π-π interaction than phenyl column 	<ul style="list-style-type: none"> Strongest π-π interaction 	<ul style="list-style-type: none"> Dipole-dipole interaction 	<ul style="list-style-type: none"> Dispersion force interaction

*For 2.5Cholester, 2.5πNAP (2.5 μm), please refer to page 62.

For more information on interaction, please refer to Technical Information 7, Selectivity of packing materials in reversed phase liquid chromatography at page 201.

Column Selection Guide

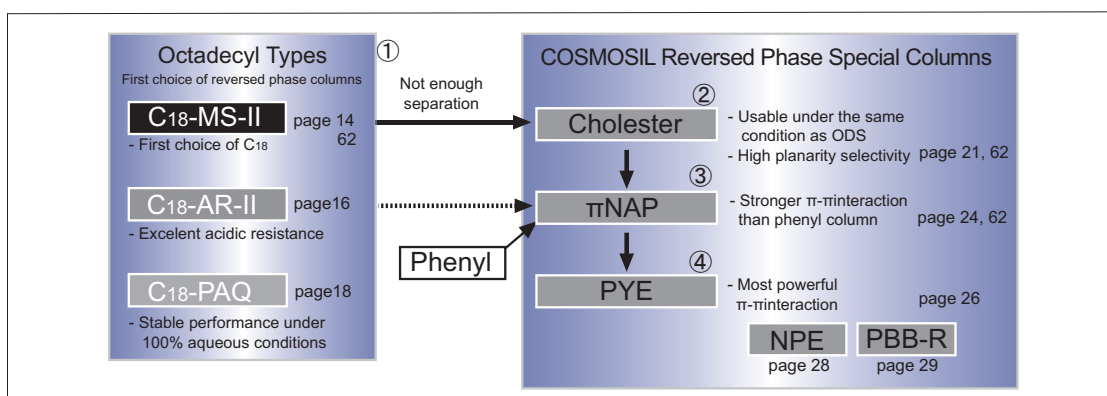

The number in Selection Guide: The order of selection column

COSMOSIL Cholester

- Cholesterol bonded stationary phase
- Usable under condition the same as C₁₈
- Increased stereoselectivity and improved resolution for geometric isomers
- For separation of natural compounds

Hydrophobic Interaction

Figure shows the comparison of hydrophobic interactions with competitive C₁₈ columns. Cholester provides the same hydrophobicity as alkyl group bonded types (C₁₈, C₃₀). It is not necessary to change the analytical conditions when replacing C₁₈ or C₃₀ columns with Cholester.

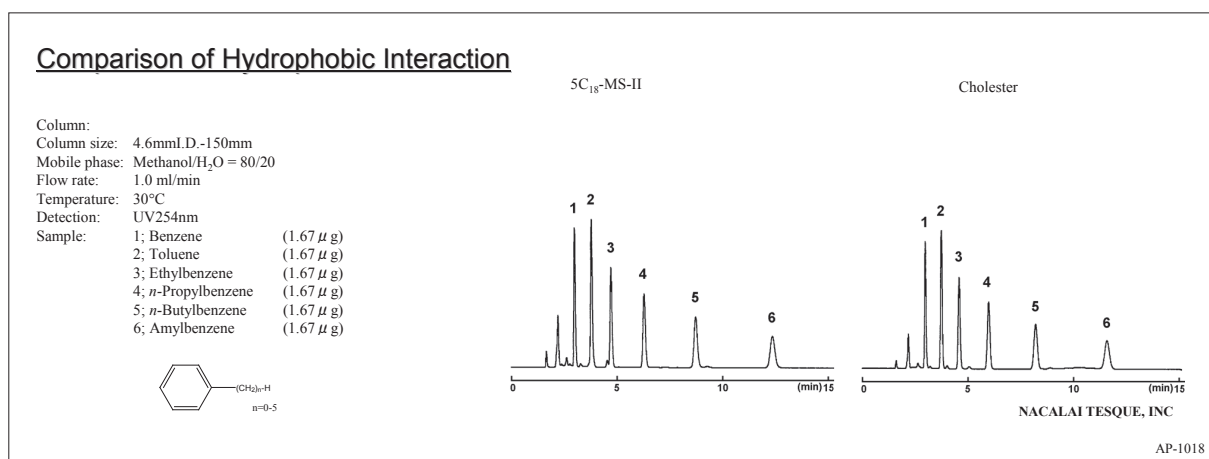

Molecular Shape Selectivity

The stationary phase of Cholester has very rigid structures and can distinguish different molecular shapes. Cholester offers improved separation for structurally similar compounds that are difficult to analyze with alkyl group bonded materials (C₁₈ and C₃₀). As in the following example Cholester retains planar Triphenylene longer than stereoscopic *o*-Terphenyl.

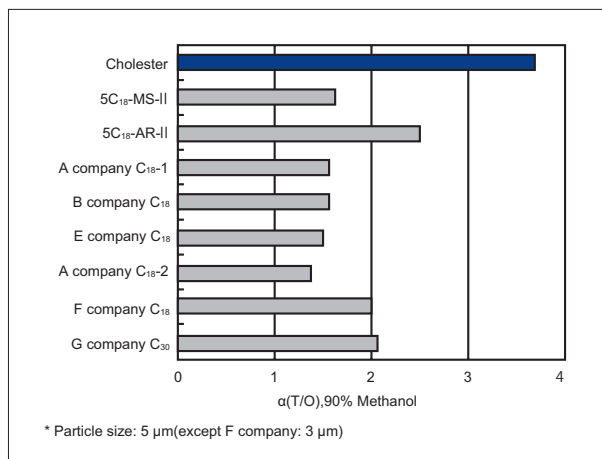
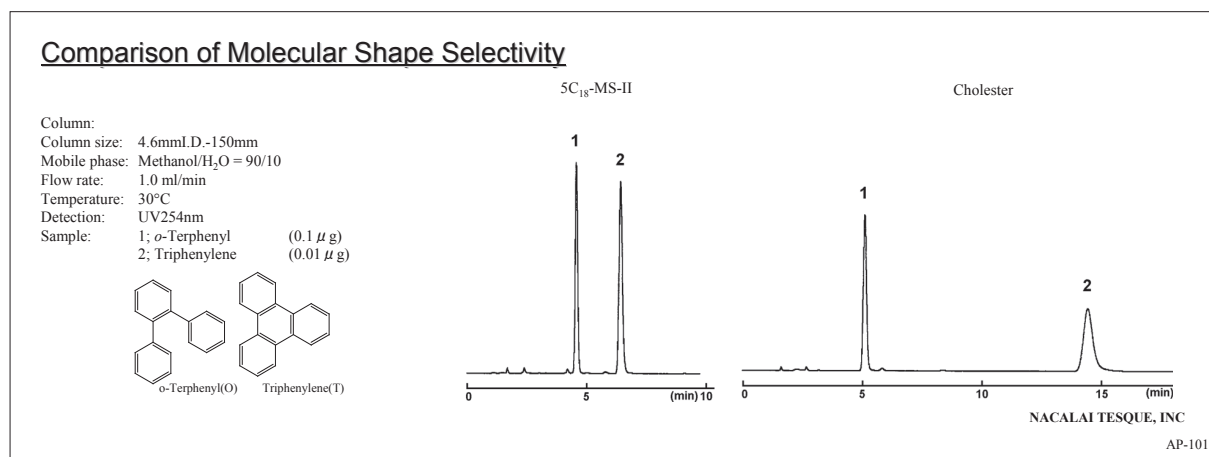

Figure. Comparison of molecular sharp selectivity



Improvement in Separation

COSMOSIL Cholester provides enhanced selectivity over traditional C₁₈ columns and offers greater performance in separating isomers or other closely related compounds. COSMOSIL Cholester is ideal for method development and serves as an excellent alternative to traditional C₁₈ columns. The figure below shows analytical data of chloroacetophenone isomers. These isomers are difficult to separate with C₁₈ and C₃₀, but they are well resolved by COSMOSIL Cholester.

Comparison with Competitors' C₁₈ and C₃₀ columns

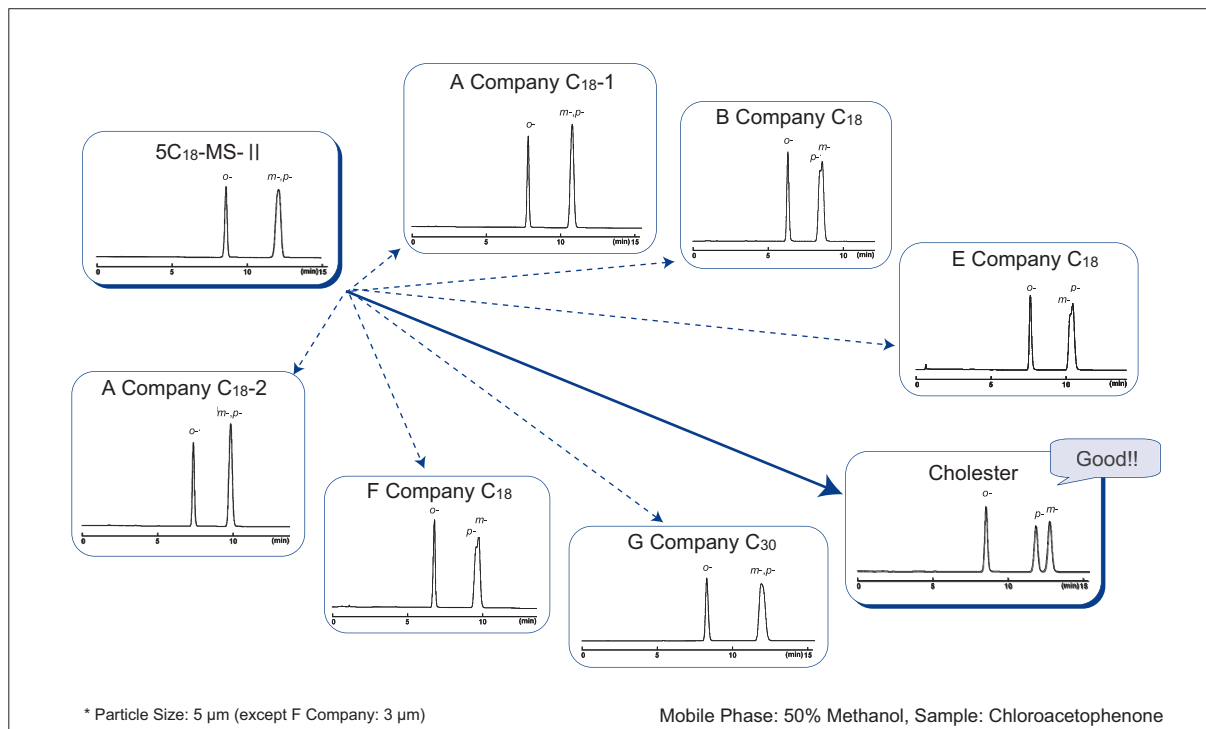

Efficiency of Preparative Separation

The figure below shows the comparison of efficiency of preparative separation with a C₁₈ column. Both columns show good separation. However, sample loading capacity for preparative separations can be affected by a slight difference in separation ability. COSMOSIL Cholester can load 4 times of sample volume compared with C₁₈ columns.

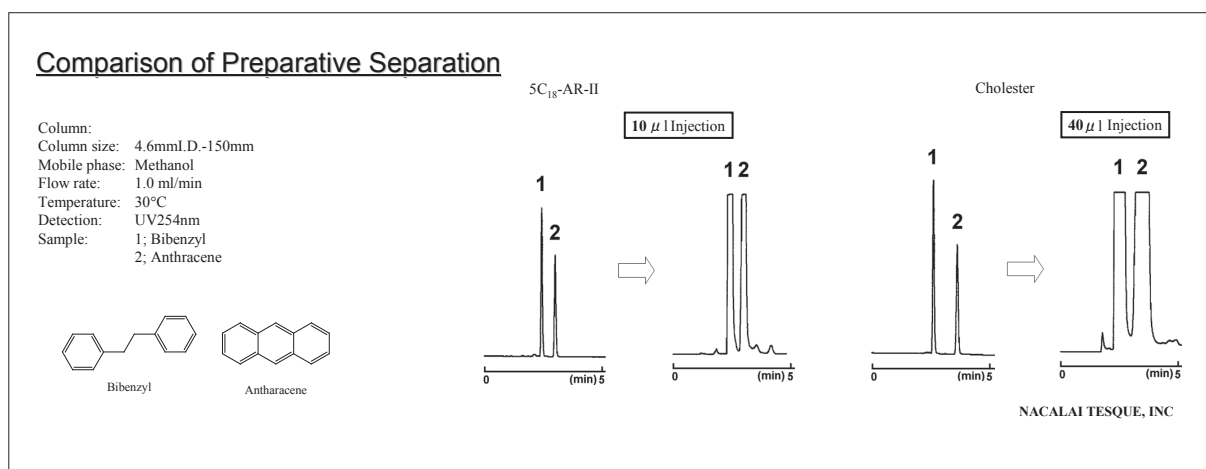

Applications

• Catechins

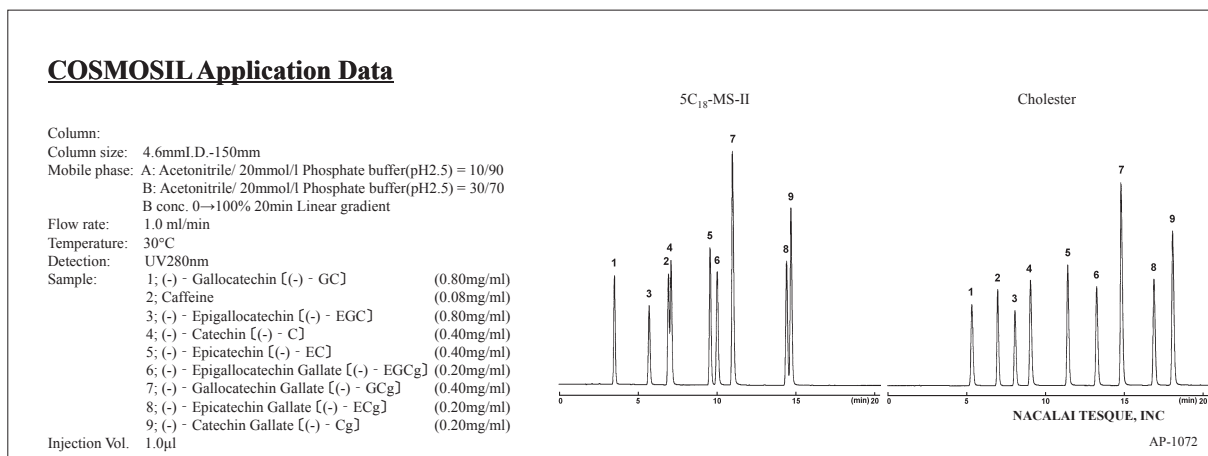

• Flavones

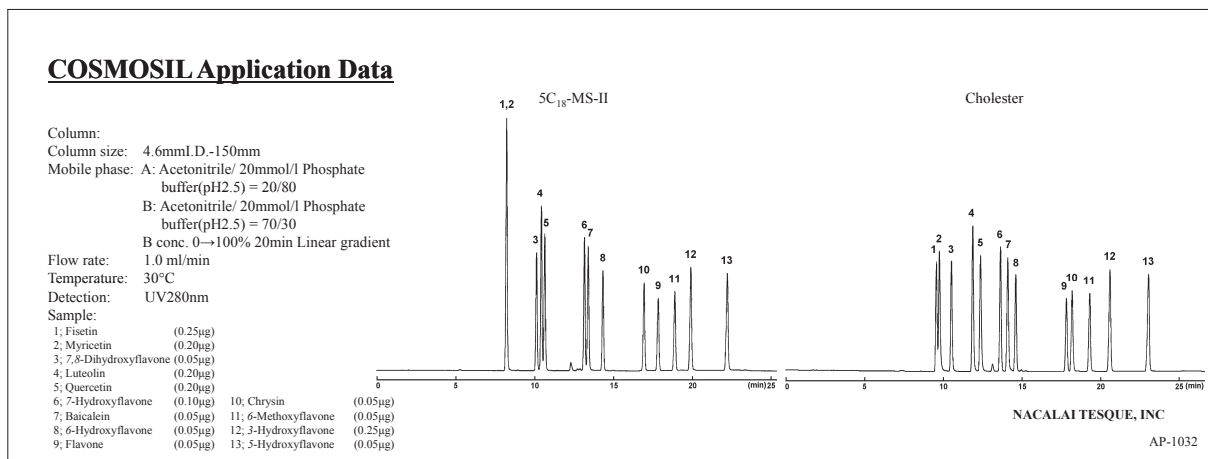

Ordering Information

• Analytical / Preparative Column (Particle Size: 5 µm)

COSMOSIL Cholester Packed Column

Column Size I.D. x Length (mm)	Product Number	Column Size I.D. x Length (mm)	Product Number
1.0 x 150	05968-71	4.6 x 150	05976-61
1.0 x 250	05969-61	4.6 x 150 3 lots set*	07970-03
2.0 x 30	08565-51	4.6 x 250	05977-51
2.0 x 50	06352-91	10 x 150	08011-91
2.0 x 100	06948-01	10 x 250	05979-31
2.0 x 150	05971-11	20 x 150	06088-71
2.0 x 250	05972-01	20 x 250	05982-71
3.0 x 150	05973-91	28 x 250	05985-41
3.0 x 250	05974-81		

*For 4.6 x 150 3 lots set, please refer to page 11.

For more information on 2.5Cholester (2.5 µm), please refer to page 62.

COSMOSIL Cholester Guard Column

Column Size I.D. x Length (mm)	Product Number
4.6 x 10	05975-71
10 x 20	05978-41
20 x 20	05980-91
20 x 50	05981-81
28 x 50	05983-61

COSMOSIL π NAP

- Naphthalene bonded stationary phase
- Enhanced π - π interactions
- Improved selectivity for structural isomers

Comparison of π - π interactions

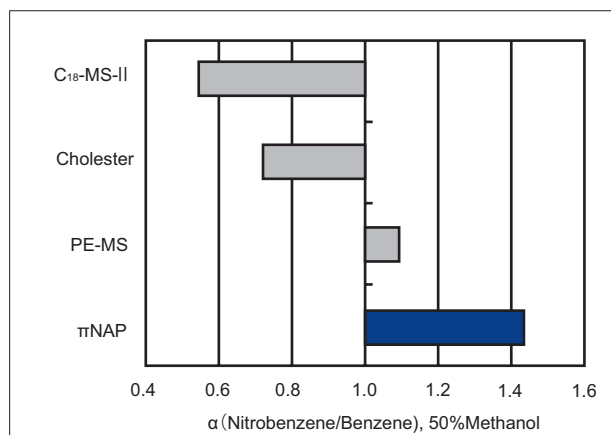
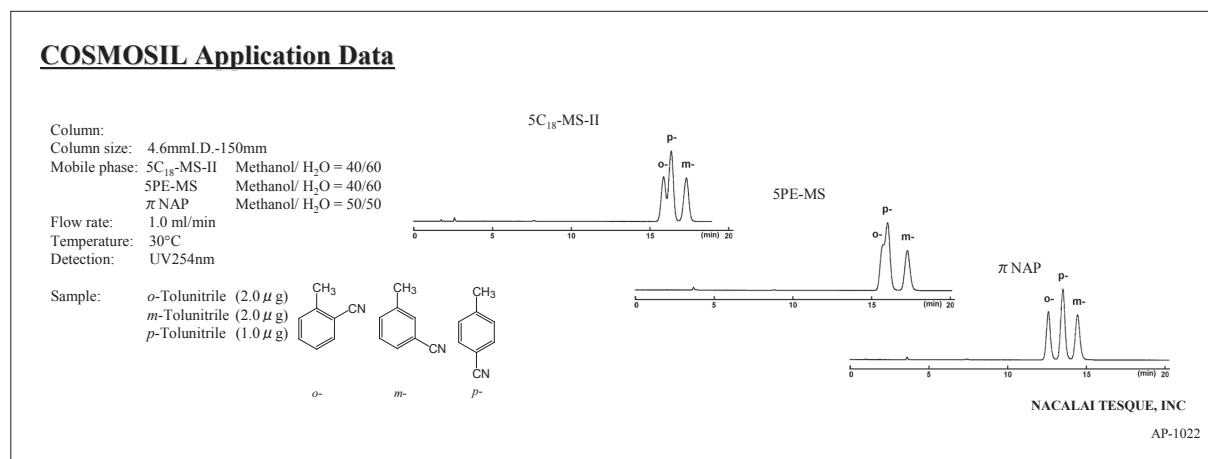

Figure. Comparison of π - π interaction

COSMOSIL π NAP shows stronger π - π interactions than phenyl columns. Its two fused aromatic rings retain nitrobenzene with more π electrons stronger than phenyl columns.

Applications

- Tolunitriles



- Adrenal Cortical Hormones

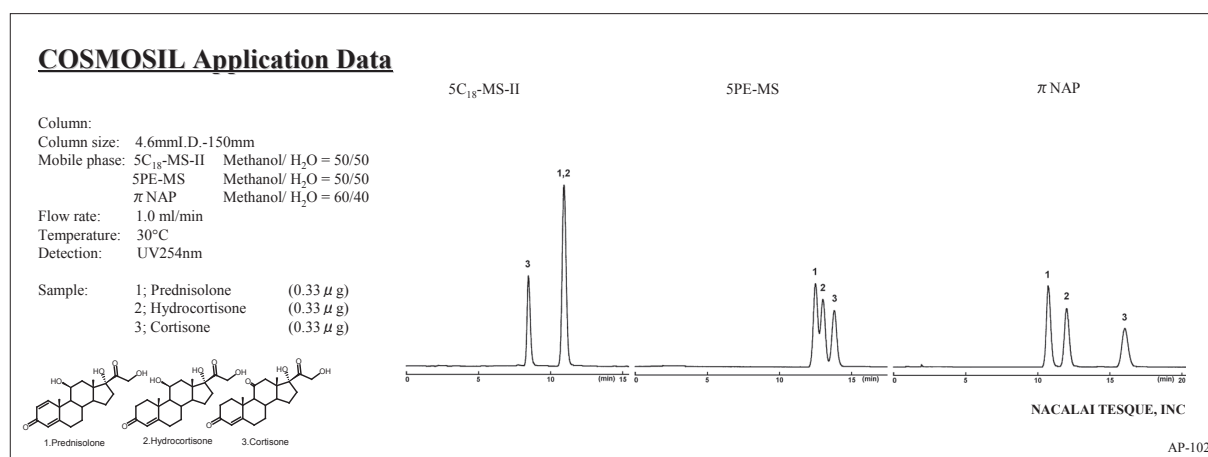

Applications

• Berberines

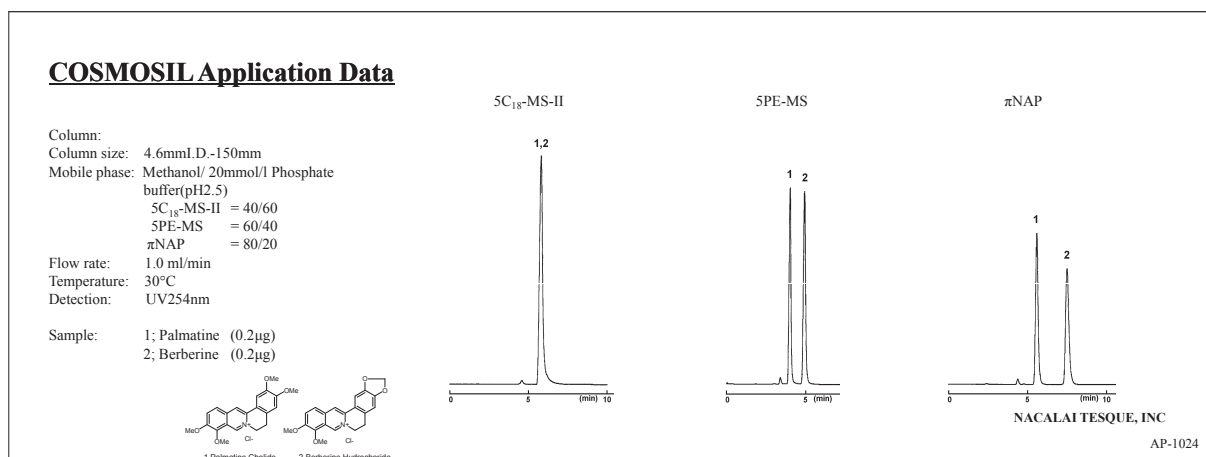

• Isoflavones

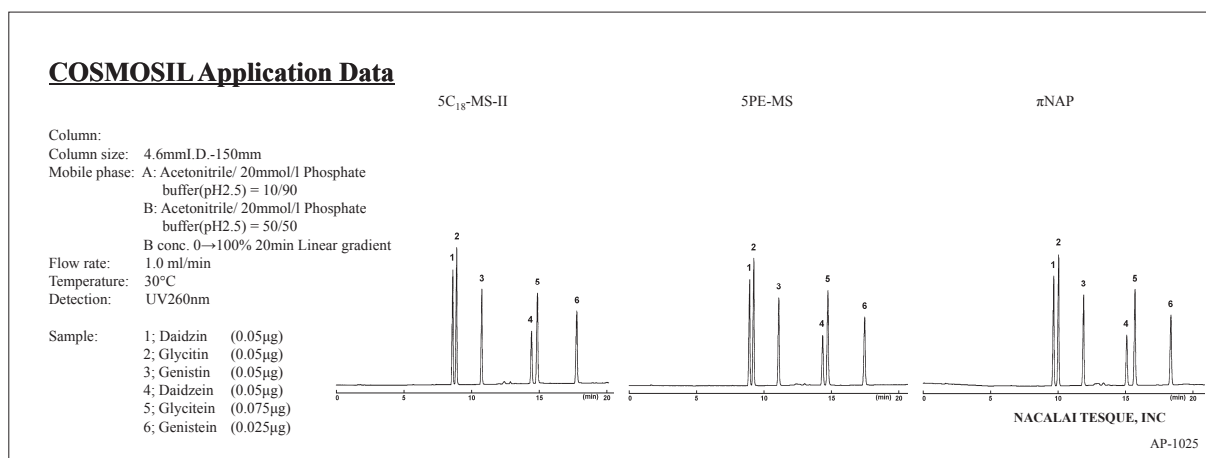

Ordering Information

• Analytical / Preparative Column (Particle Size: 5 μm)

COSMOSIL πNAP Packed Column

Column Size I.D. x Length (mm)	Product Number	Column Size I.D. x Length (mm)	Product Number
1.0 x 150	08076-61	3.0 x 250	08081-81
1.0 x 250	08077-51	4.6 x 150	08085-41
2.0 x 30	08566-41	4.6 x 250	08086-31
2.0 x 50	08567-31	10 x 150	08088-11
2.0 x 100	08299-51	10 x 250	08089-01
2.0 x 150	08078-41	20 x 150	08092-41
2.0 x 250	08079-31	20 x 250	08093-31
3.0 x 150	08080-91	28 x 250	08095-11

COSMOSIL πNAP Guard Column

Column Size I.D. x Length (mm)	Product Number
4.6 x 10	08082-71
10 x 20	08087-21
20 x 20	08090-61
20 x 50	08091-51
28 x 50	08094-21

For more information on 2.5πNAP (2.5 μm), please refer to page 62.

COSMOSIL PYE

- Pyrenylethyl group bonded stationary phase
- Separation with high molecular shape selectivity or π - π interactions
- Excellent separation for structural isomers

Comparison of π - π interaction

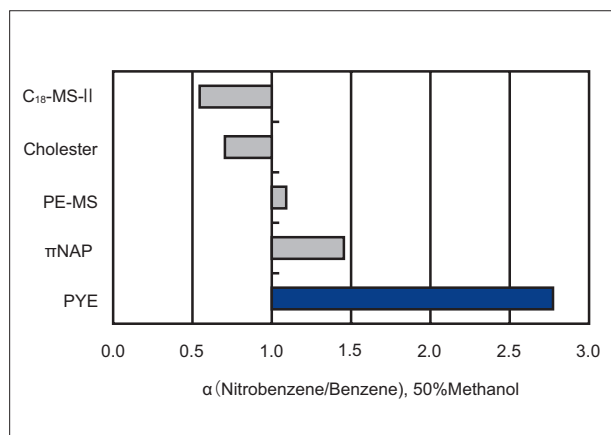

COSMOSIL PYE provides much stronger π - π interactions than π NAP on page 24.

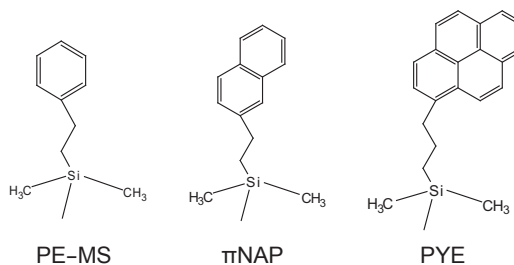
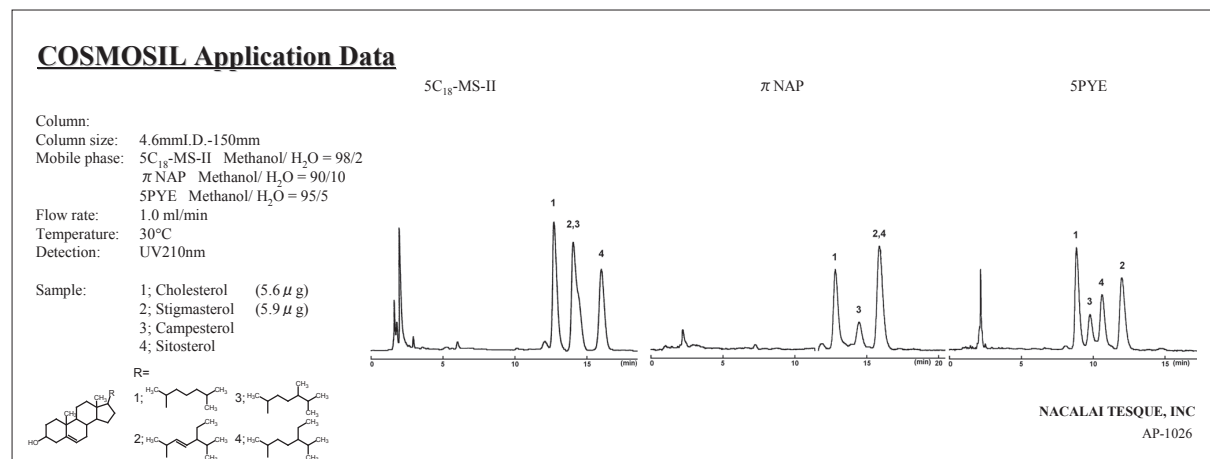

Figure. Comparison of π - π interactions

Applications

- Sterols



- Phthalonitriles

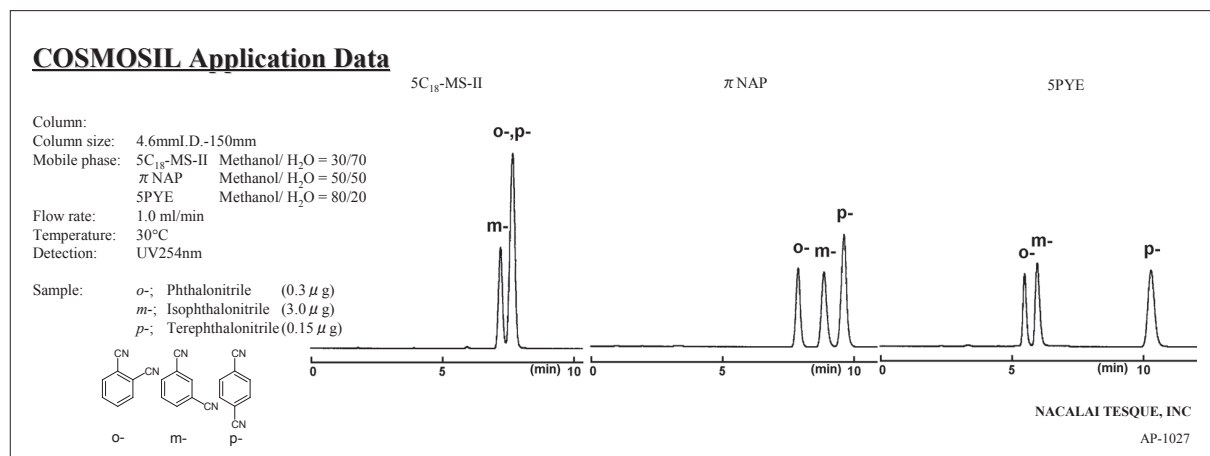

Applications

• Tocopherols

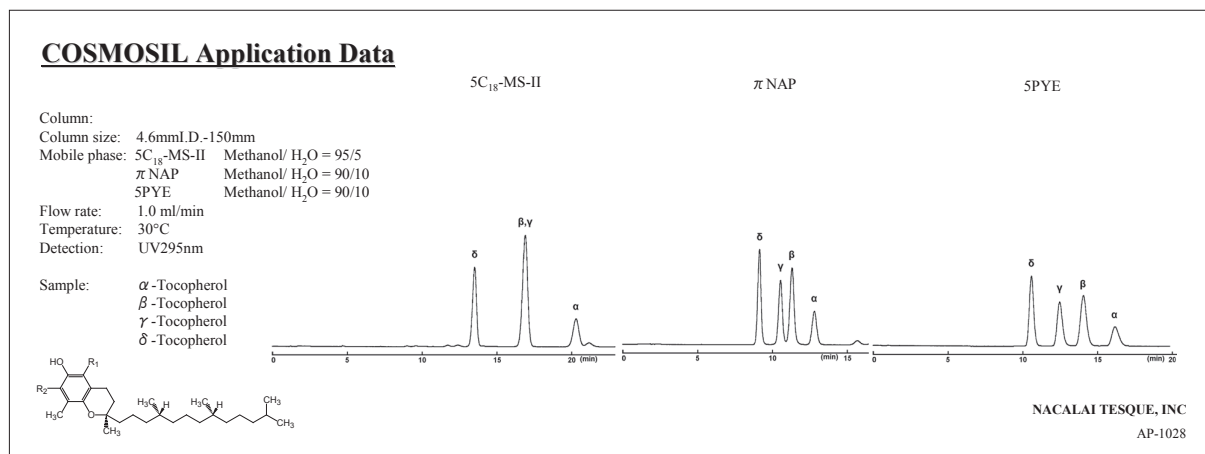

• Capsaicins

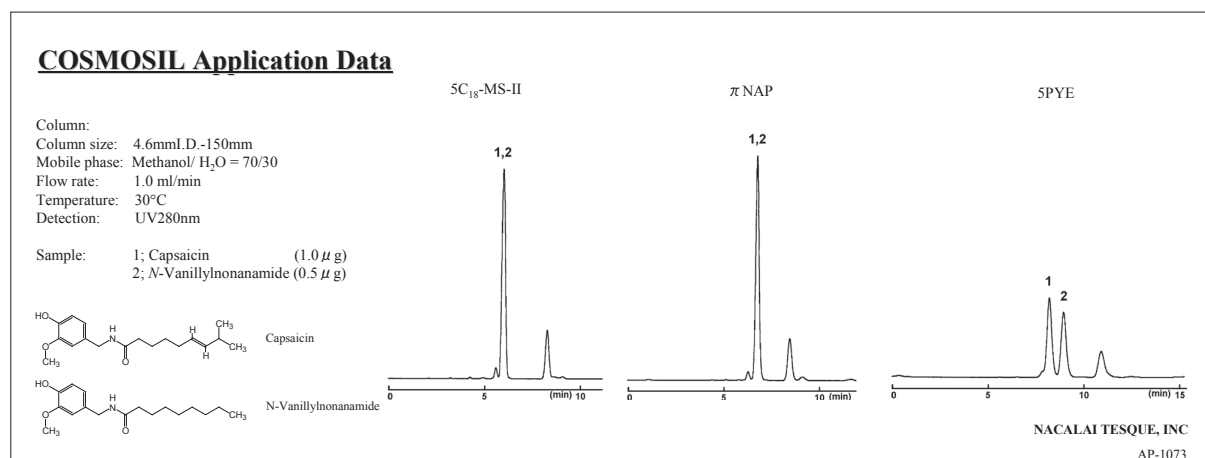

Attention

1. Methanol is recommended as a mobile phase for COSMOSIL PYE column. Acetonitrile is not recommended because it has many π electrons and interferes π-π interactions between a sample and the stationary phase.
2. The stationary phase of COSMOSIL PYE, pyrenylethyl group, has a large UV absorption. When the stationary phase detaches from silica gel and elutes, even a slight quantity can be detected and causes baseline noise. In such a case, wash the column with tetrahydrofuran. Detachment of a small amount of the stationary phase does not deteriorate a column's separation ability.
3. COSMOSIL PYE column is not suitable for gradient analysis.

Ordering Information

• Analytical / Preparative Column (Particle Size: 5 μm)

COSMOSIL 5PYE Packed Column

Column Size I.D. x Length (mm)	Product Number
1.0 x 150	02851-71
2.0 x 150	38042-61
2.0 x 250	34450-31

COSMOSIL 5PYE Guard Column

Column Size I.D. x Length (mm)	Product Number
4.6 x 150	37837-91
4.6 x 250	37989-11
10 x 250	37996-11
20 x 250	38044-41

Column Size I.D. x Length (mm)	Product Number
4.6 x 10	37903-11
10 x 20	38041-71
20 x 20	05867-91
20 x 50	34475-21

COSMOSIL NPE

- Nitrophenylethyl group bonded stationary phase
- Separation with dipole-dipole and π - π interactions
- Excellent separation for structural isomers

Selectivity for Dipole-dipole Interactions

COSMOSIL NPE strongly retains 1,8-dinitronaphthalene because of the strong dipole formed by the two nitro groups positioned on the same side of naphthalene.

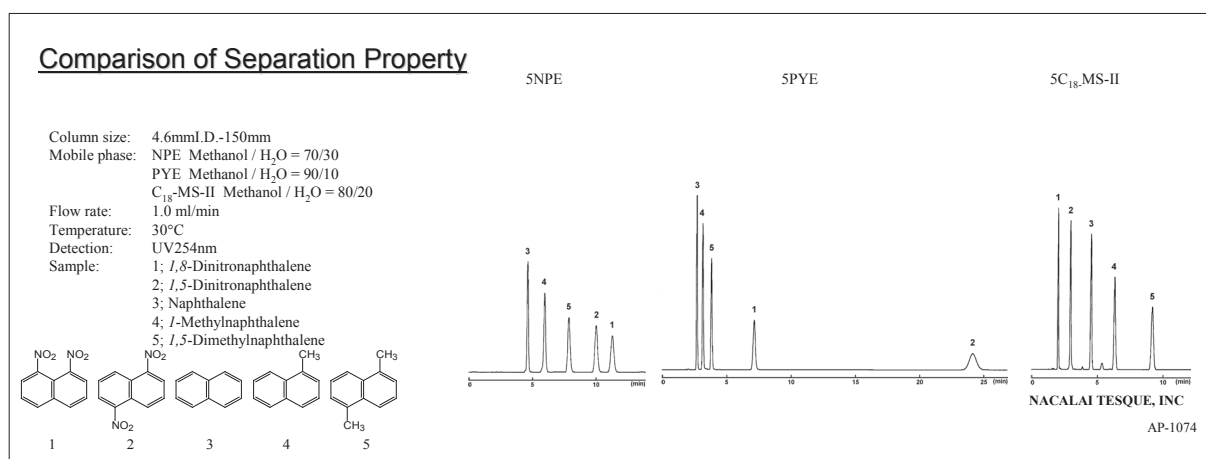

Attention

1. Methanol is recommended as a mobile phase for COSMOSIL NPE column. Acetonitrile is not recommended because it has many π electrons and interferes π - π interactions between a sample and the stationary phase.
2. The stationary phase of COSMOSIL NPE, nitrophenyl group, has a large UV absorption. When the stationary phase detaches from silica gel and elutes, even a slight quantity can be detected and causes baseline noise. In such a case, wash the column with tetrahydrofuran. Detachment of a small amount of the stationary phase does not deteriorate a column's separation ability.
3. COSMOSIL NPE column is not suitable for gradient analysis.

Ordering Information

- Analytical / Preparative Column (Particle Size: 5 μ m)

COSMOSIL 5NPE Packed Column

Column Size I.D. x Length (mm)	Product Number
1.0 x 150	05897-01
2.0 x 150	34328-51
2.0 x 250	34379-91

COSMOSIL 5NPE Guard Column

Column Size I.D. x Length (mm)	Product Number	Column Size I.D. x Length (mm)	Product Number	Column Size I.D. x Length (mm)	Product Number
4.6 x 150	37902-21	4.6 x 10	37904-01	4.6 x 10	37904-01
4.6 x 250	37990-71	10 x 20	38045-31	10 x 20	38045-31
10 x 250	05469-11	20 x 20	05868-81	20 x 20	05868-81
20 x 250	38046-21	20 x 50	05869-71	20 x 50	05869-71

COSMOSIL PBB-R

- Pentabromobenzyl bonded stationary phase
- Separation with dispersion force interaction
- Distinguish various surfactants' polyethylene glycol chain length
- For separation of halogen exchange reaction products or aromatic compounds

Applications

• Halogen Exchange Reaction Products

COSMOSIL PBB-R strongly retains iodine atom which has a large dispersion force, than bromine atom. So it can separate halogen exchange reaction products that are difficult to analyze with C₁₈ column.

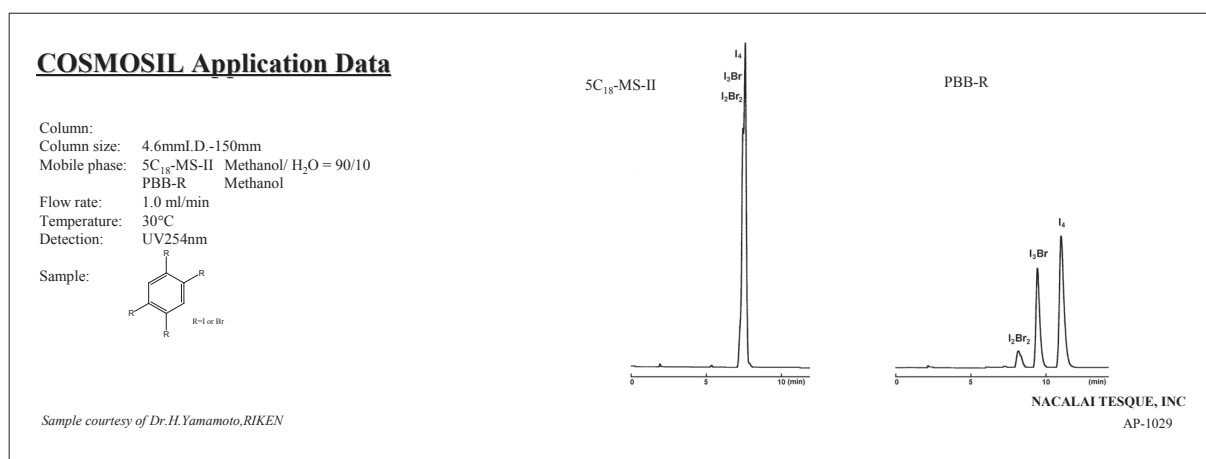

• Surfactant Agents

C₁₈ column can not separate Triton X-100 mixture, because (-OCH₂CH₂-) group has little hydrophobicity. However, COSMOSIL PBB-R can separate them because it distinguishes difference in the dispersion force, which depends on its molecular weight.

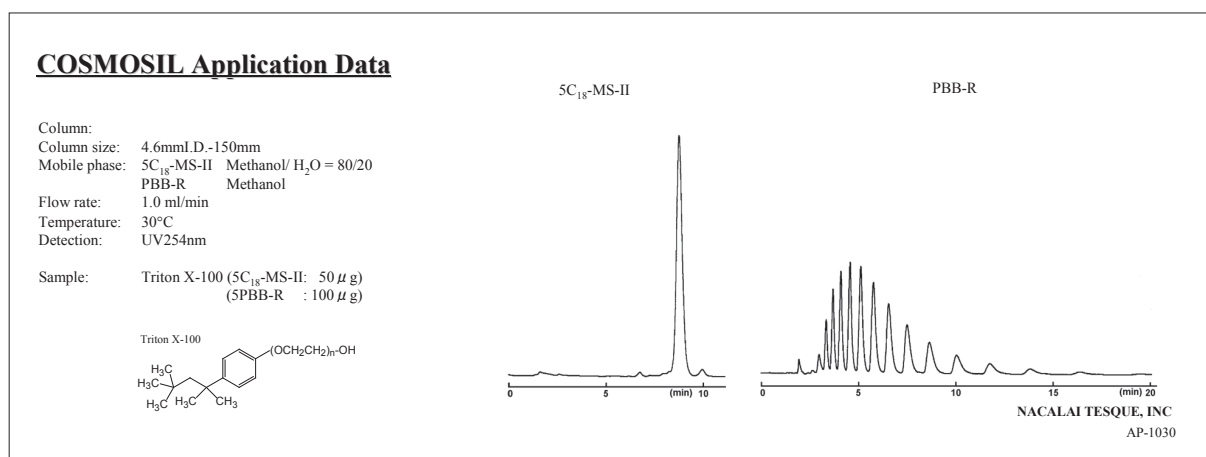

Ordering Information

- Analytical / Preparative Column (Particle Size: 5 μm)

COSMOSIL 5PBB-R Packed Column

Column Size I.D. x Length (mm)	Product Number
1.0 x 150	05899-81
2.0 x 150	05900-31
2.0 x 250	05904-91

COSMOSIL 5PBB-R Guard Column

Column Size I.D. x Length (mm)	Product Number	Column Size I.D. x Length (mm)	Product Number	Column Size I.D. x Length (mm)	Product Number
4.6 x 150	05697-21	4.6 x 10	05704-11	10 x 20	05721-81
4.6 x 250	05698-11	10 x 20	05911-91	20 x 20	05911-91
10 x 250	05699-01	20 x 50	05722-71		
20 x 250	05700-51				

(3) Other Reversed Phase HPLC Columns

Specifications

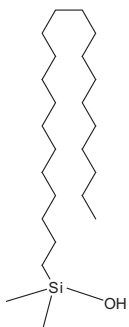
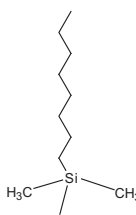
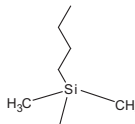
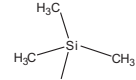
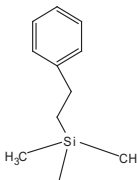
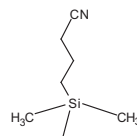
Packing Material	C ₂₂ -AR-II	C ₈ -MS	C ₄ -MS	TMS-MS	PE-MS	CN-MS
Silica Gel	High Purity Porous Spherical Silica					
Average Particle Size	5 μm					
Average Pore Size	approx. 120 Å					
Specific Surface Area	approx. 300 m ² /g					
Bonded Phase Structure						
Bonded Phase	Dococyl Group	Octyl Group	Butyl Group	Trimethyl Group	Phenylethyl Group	Cyanopropyl Group
Bonding Type	Polymeric	Monomeric				
Main Interaction	Hydrophobic Interaction				Hydrophobic Interaction π-π Interaction	
End-capping Treatment	Near-perfect Treatment					
Carbon Load	approx. 19%	approx. 10%	approx. 7%	approx. 5%	approx. 10%	approx. 7%

Different of Separation Characteristic

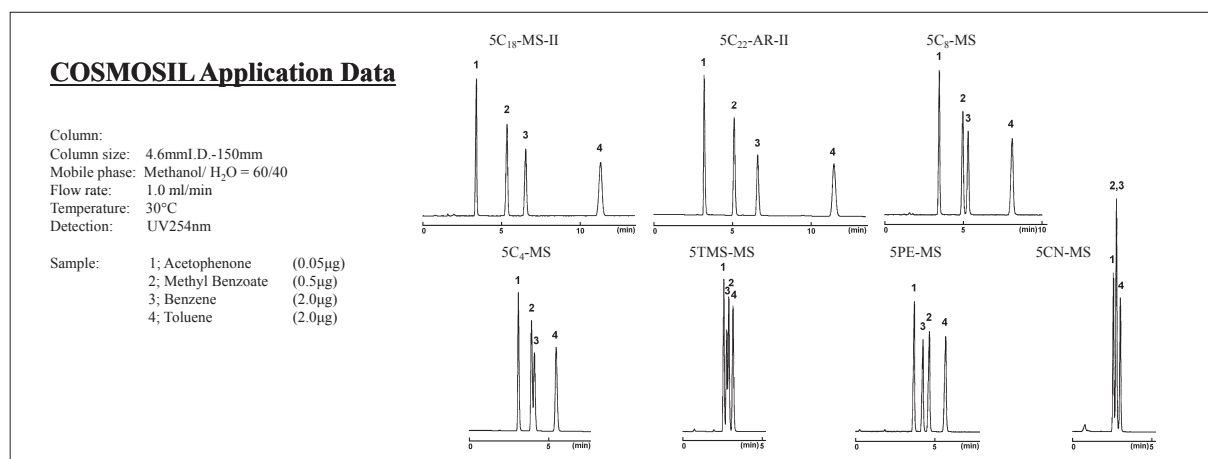

COSMOSIL CN-MS

- Cyanopropyl group bonded stationary phase
- Enables separation of different hydrophobic samples without using gradient
- For separation of natural compounds with different hydrophobicity

Rapid Analysis

Gradient elution is commonly used for the samples containing both polar and non-polar compounds. However, gradient elution may cause reproducibility problem depending on the gradient mixer and pump, and need an equilibration time for each analysis. COSMOSIL 5CN-MS offers rapid analysis and great reproducibility using isocratic elution mode.

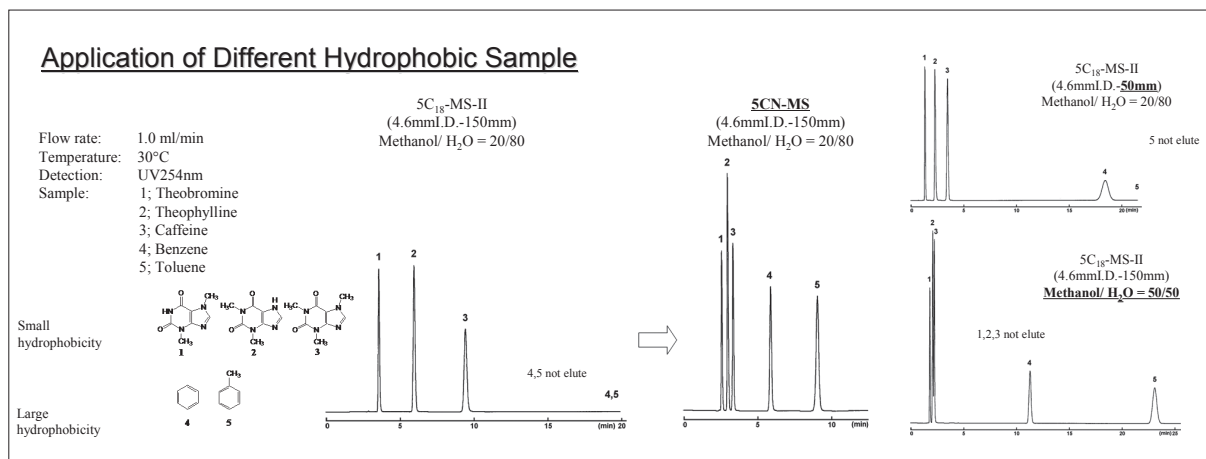

Applications

- Acetoaminophen

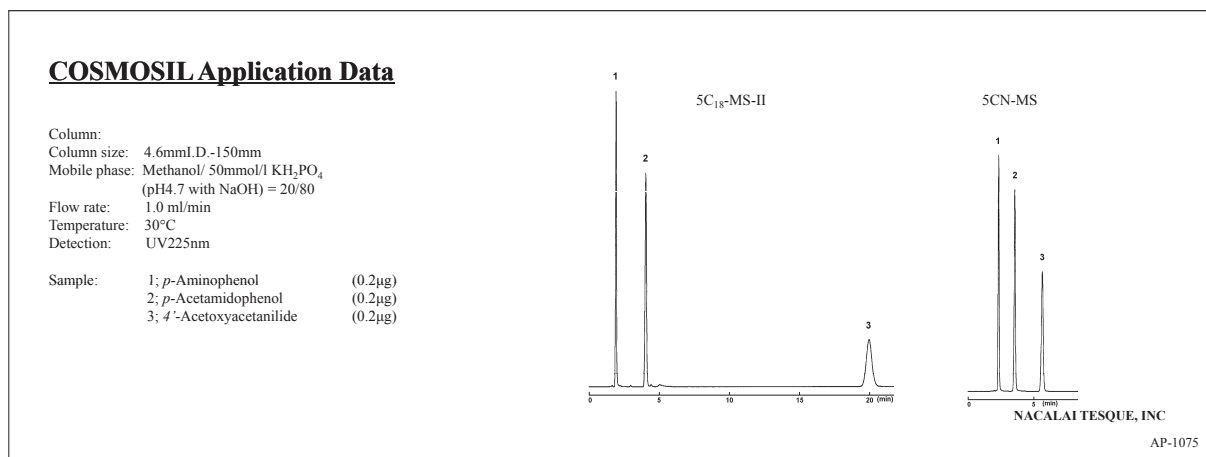

Ordering Information

- Analytical / Preparative Column (Particle Size: 5 µm)

COSMOSIL 5CN-MS Packed Column

Column Size I.D. x Length (mm)	Product Number
4.6 x 50	38233-61
4.6 x 100	38234-51
4.6 x 150	38235-41
4.6 x 250	38236-31

COSMOSIL 5CN-MS Guard Column

Column Size I.D. x Length (mm)	Product Number
4.6 x 10	38231-81
10 x 20	38232-71

Column Size I.D. x Length (mm)	Product Number
6.0 x 150	38237-21
6.0 x 250	38238-11
10 x 250	38239-01
20 x 250	38240-61

COSMOSIL C₂₂-AR-II, C₈-MS, C₄-MS, TMS-MS, PE-MS

Ordering Information

- Analytical / Preparative Column (Particle Size: 5 µm)

COSMOSIL 5C₂₂-AR-II Packed Column

Column Size I.D. x Length (mm)	Product Number	Column Size I.D. x Length (mm)	Product Number
4.6 x 50	05848-41	6.0 x 150	05850-91
4.6 x 100	05849-31	6.0 x 250	05851-81
4.6 x 150	04598-51	10 x 250	04969-91
4.6 x 250	04599-41	20 x 250	05183-41

COSMOSIL 5C₂₂-AR-II Guard Column

Column Size I.D. x Length (mm)	Product Number
4.6 x 10	04881-21
10 x 20	05554-81

COSMOSIL 5C₈-MS Packed Column

Column Size I.D. x Length (mm)	Product Number	Column Size I.D. x Length (mm)	Product Number
4.6 x 50	38153-11	6.0 x 150	38157-71
4.6 x 100	38154-01	6.0 x 250	38158-61
4.6 x 150	38155-91	10 x 250	38159-51
4.6 x 250	38156-81	20 x 250	38160-11

COSMOSIL 5C₈-MS Guard Column

Column Size I.D. x Length (mm)	Product Number
4.6 x 10	38151-31
10 x 20	38152-21

COSMOSIL 5C₄-MS Packed Column

Column Size I.D. x Length (mm)	Product Number	Column Size I.D. x Length (mm)	Product Number
4.6 x 50	38163-81	6.0 x 150	38167-41
4.6 x 100	38164-71	6.0 x 250	38168-31
4.6 x 150	38165-61	10 x 250	38169-21
4.6 x 250	38166-51	20 x 250	38170-81

COSMOSIL 5C₄-MS Guard Column

Column Size I.D. x Length (mm)	Product Number
4.6 x 10	38161-01
10 x 20	38162-91

COSMOSIL 5TMS-MS Packed Column

Column Size I.D. x Length (mm)	Product Number	Column Size I.D. x Length (mm)	Product Number
4.6 x 50	38173-51	6.0 x 150	38177-11
4.6 x 100	38174-41	6.0 x 250	38178-01
4.6 x 150	38175-31	10 x 250	38179-91
4.6 x 250	38176-21	20 x 250	38180-51

COSMOSIL 5TMS-MS Guard Column

Column Size I.D. x Length (mm)	Product Number
4.6 x 10	38171-71
10 x 20	38172-61

COSMOSIL 5PE-MS Packed Column

Column Size I.D. x Length (mm)	Product Number	Column Size I.D. x Length (mm)	Product Number
4.6 x 50	38183-21	6.0 x 150	38187-81
4.6 x 100	38184-11	6.0 x 250	38188-71
4.6 x 150	38185-01	10 x 250	38189-61
4.6 x 250	38186-91	20 x 250	38190-21

COSMOSIL 5PE-MS Guard Column

Column Size I.D. x Length (mm)	Product Number
4.6 x 10	38181-41
10 x 20	38182-31

I. HPLC Columns

II. UHPLC Columns

III. Preparative Packing Materials

IV. Related Products

V. Applications

VI. Technical Notes

VII. Index

(4) Silica Based Preparative Columns

COSMOSIL 15C₁₈-MS-II, 15C₁₈-AR-II, 15C₁₈-PAQ

- 2 sizes of inner diameter (28 mm and 50 mm)
- 15 µm silica gel

Specifications

Packing Material	15C ₁₈ -MS-II	15C ₁₈ -AR-II	15C ₁₈ -PAQ
Silica Gel	High Purity Porous Spherical Silica		
Average Particle Size	15 µm		
Average Pore Size	approx. 120 Å		
Specific Surface Area	approx. 300 m ² /g		
Bonded Phase Structure	Please refer to page 12		
Bonded Phase	Octadecyl Group		
Bonding Type	Monomeric	Polymeric	
Main Interaction	Hydrophobic Interaction		
End-capping Treatment	Near-perfect Treatment		
Usable pH Range	2~10	1.5~7.5	2~7.5
Carbon Load	approx. 16%	approx. 17%	approx. 11%
Features	<ul style="list-style-type: none"> • Multi-purpose C₁₈ Column • Suitable for basic compounds. 	<ul style="list-style-type: none"> • Features strong acid resistance. • Suitable for acid compounds and peptides. 	<ul style="list-style-type: none"> • Suitable for hydrophilic compounds. • Compatible with 100% water based mobile phase.

Applications

- Preparative separation of carbazole using 50 mm I.D. column

Carbazole is extracted from anthracene oil (coal tar) and required high purity because it is often used for analytical applications. Following is the preparative separation of carbazol using a 50 mm I.D. COSMOSIL 15C₁₈-AR-II.

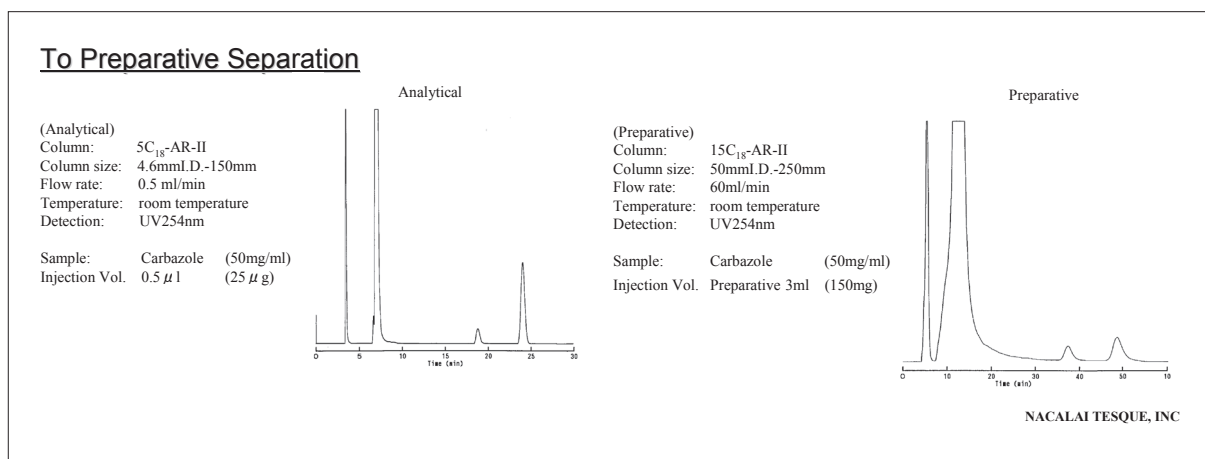

Refer to Technical Information 2, Inner diameter of column (scale down and scale up) at page 189.

Ordering Information

Refer to page 15 for 15C₁₈-MS-II , page 17 for 15C₁₈-AR-II and page 19 for 15C₁₈-PAQ.

6. Normal Phase Chromatography Column

COSMOSIL SL-II

- High purity silica gel (>99.99%) with special treatment
- Suitable for preparative separation

Specifications

Packing Material	SL-II
Silica Gel	High Purity Porous Spherical Silica
Average Particle Size	3, 5, 15 μm
Average Pore Size	approx. 120 \AA
Specific Surface Area	approx. 300 m^2/g
Features	<ul style="list-style-type: none"> • High purity silica gel (>99.99%) with special treatment • Suitable for preparative separation (high resolution than medium-pressure or open chromatography)

Comparison with Old Type

COSMOSIL SL-II with high purity silica gel offers better peak shape for phenols with simple mobile phase of ethanol or hexane. No acetic acid additives were required, unlike for the old type silica.

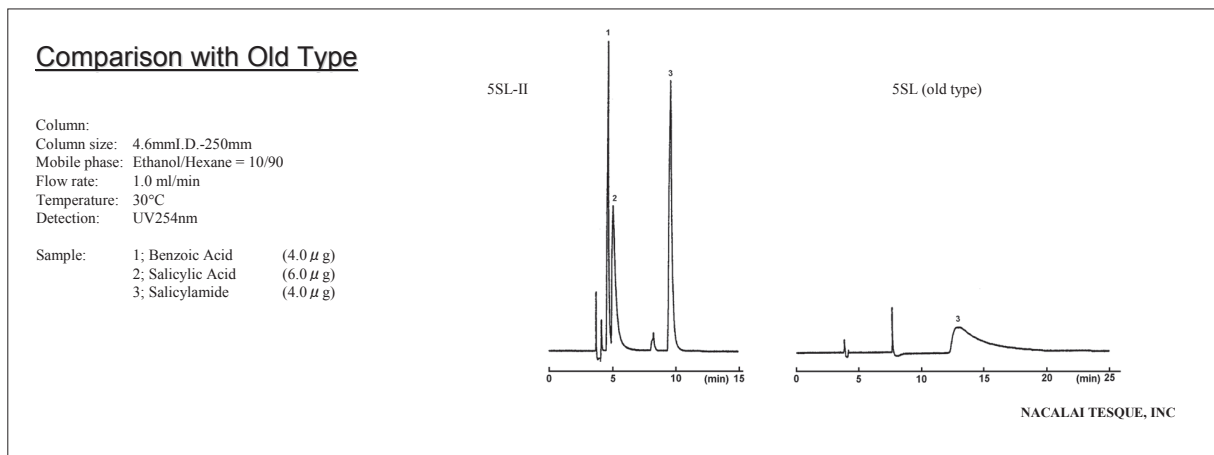

Comparison with Medium-pressure Column

COSMOSIL SL-II offers sharper peak compared with packing materials for medium-pressure liquid chromatography and open chromatography.

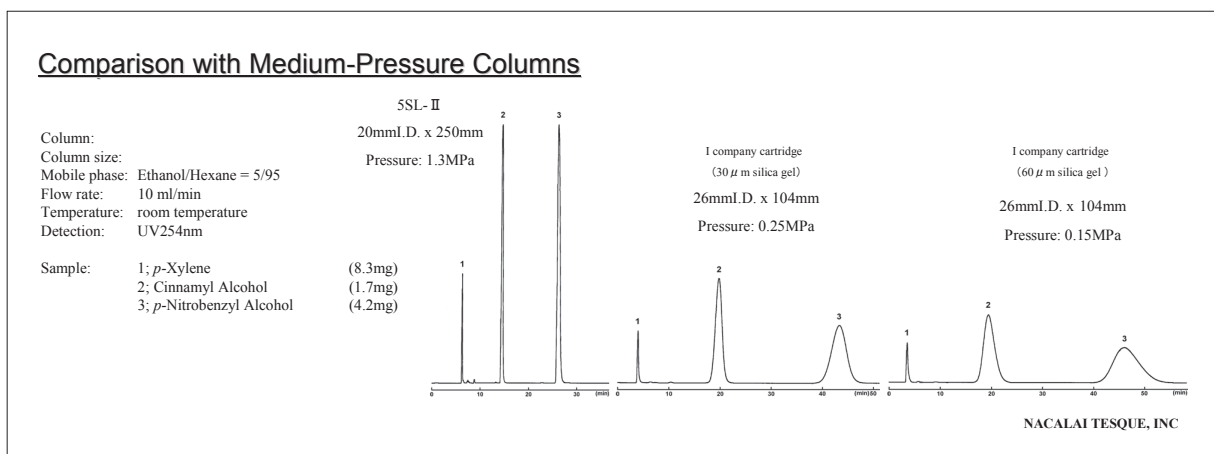

Scaling Up from Analytical to Preparative Separation

Normal phase chromatography, with non-polar mobile phase and low boiling point is used for preparative separation because solvent removal is generally easier for normal phase chromatography than for reversed chromatography. The followings are how to scale up from analytical (4.6 mm I.D.) to preparative (20.0 mm I.D.) separation.

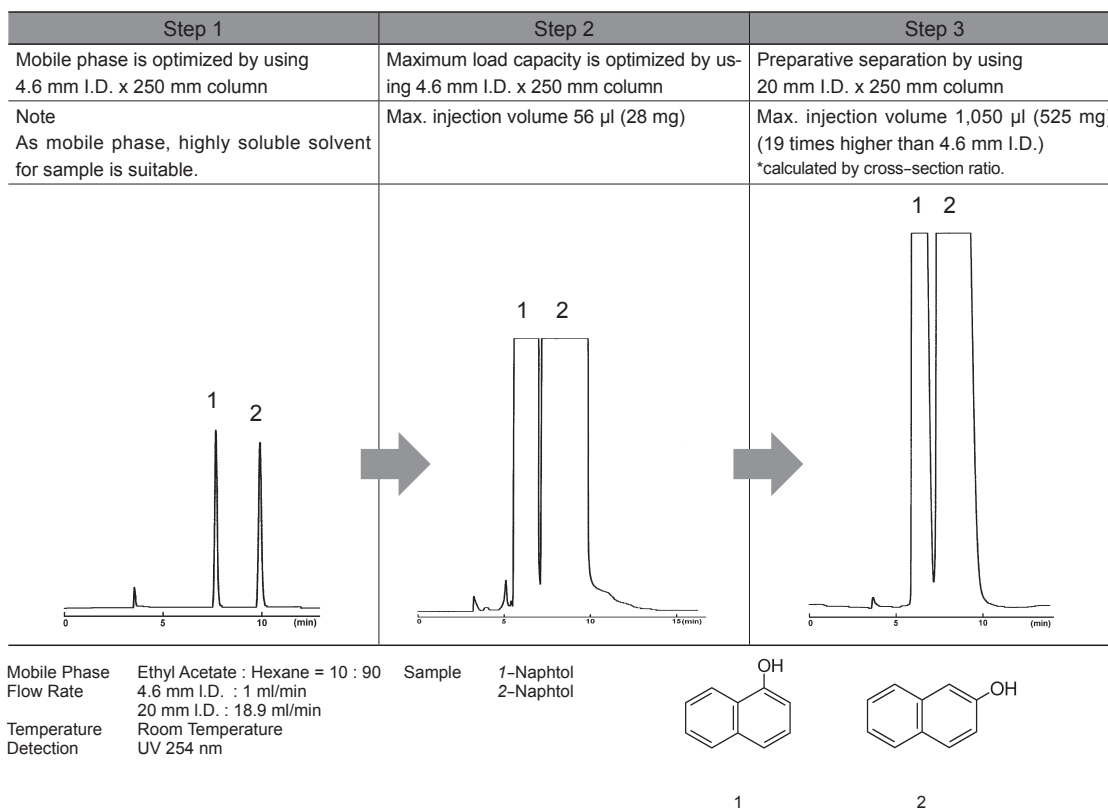

Please refer to Technical Information 2, Inner diameter of column (scale down and scale up) at page 189.

Ordering Information

• Analytical / Preparative Column (Particle Size: 5 µm)

COSMOSIL 5SL-II Packed Column

Column Size I.D. x Length (mm)	Product Number
4.6 x 50	37999-81
4.6 x 100	38000-01
4.6 x 150	38001-91
4.6 x 250	38002-81

COSMOSIL 5SL-II Guard Column

Column Size I.D. x Length (mm)	Product Number
6.0 x 150	38003-71
6.0 x 250	38004-61
10 x 250	38005-51
20 x 250	38006-41
28 x 250	34358-61
4.6 x 10	37997-01
10 x 20	37998-91
20 x 20	05874-91
20 x 50	05875-81
28 x 50	34359-51

• Preparative Column (Particle Size : 15 µm)

COSMOSIL 15SL-II Packed Column

Column Size I.D. x Length (mm)	Product Number
28 x 250	05893-41
50 x 250	05895-21
50 x 500	05896-11

COSMOSIL 15SL-II Guard Column

Column Size I.D. x Length (mm)	Product Number
28 x 50	05892-51
50 x 50	05894-31

• Fast LC column (Particle Size: 3 µm)

COSMOSIL 3SL-II Packed Column

Column Size I.D. x Length (mm)	Product Number
4.6 x 10	38059-61
4.6 x 50	38060-21
4.6 x 100	38061-11

7. Hydrophilic Interaction Chromatography Column

COSMOSIL HILIC

- Triazole bonded stationary phase
- Enhanced hydrophilic interaction
- Excellent retention for highly polar analytes
- Unique anion-exchange mechanism

Specifications

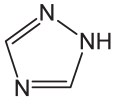
Packing Material	HILIC
Silica Gel	High Purity Porous Spherical Silica
Average Particle Size	5 μm
Average Pore Size	approx. 120 \AA
Specific Surface Area	approx. 300 m^2/g
Bonded Phase Structure	
Bonded phase	Triazole
Interaction	Hydrophilic Interaction, Anion Exchange
Object substance	Hydrophilic Compounds, Acidic Compounds
Features	Suitable for non-retaining by C_{18}

Comparison with C_{18}

The hydrophilic interaction chromatography is a variation of normal phase chromatography where a polar stationary phase is used with a mobile phase which contains a high concentration of water miscible organic solvent and a low concentration of aqueous eluent. The main retention mechanism is the partitioning of the polar analytes between the polar stationary and the non-polar mobile phase. As it is also called "aqueous normal phase", the elution order is similar to that of normal phase and the sample elution is in the order of increasing hydrophilicity. Without using ion-pair reagent COSMOSIL HILIC retains highly polar analytes that would not be retained in reversed phase chromatography. It also shows a weak anion-exchange mechanism with the positively charged stationary phase, thus acidic compound is strongly retained.

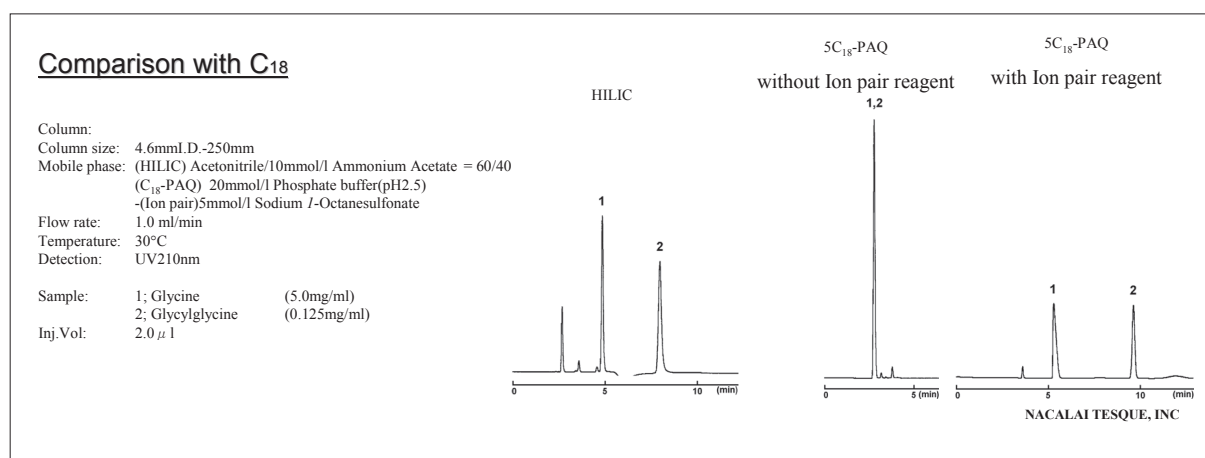

Applications

● Melamine Related Compounds

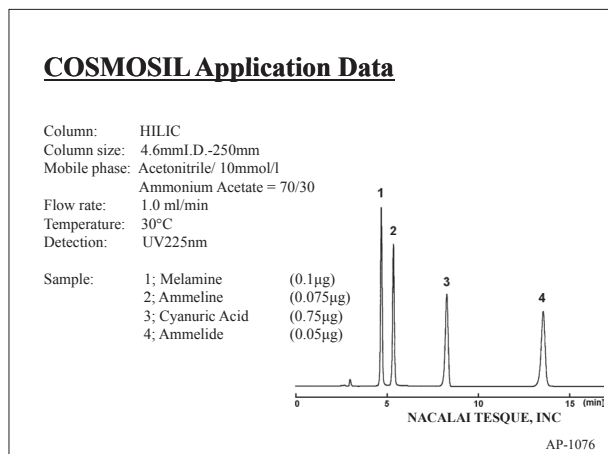

● BCAA (amino acid branched-chain)

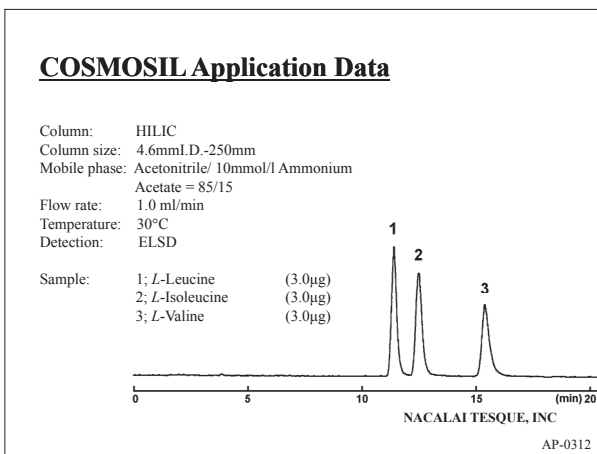

Optimizing Analytical Conditions

The COSMOSIL HILIC Chromatogram Index, which includes 167 chromatograms using COSMOSIL HILIC, is available on the NACALAI TESQUE website at <http://www.nacalai.co.jp/en/cosmosil/>. This index is a useful tool for all chromatographers, assisting them to optimize analytical conditions for hydrophilic interaction chromatography.

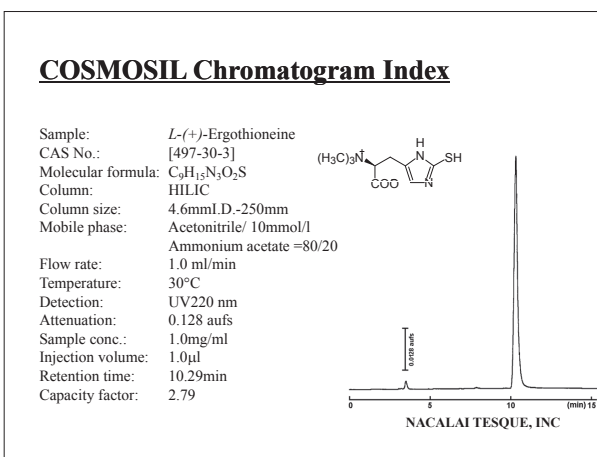
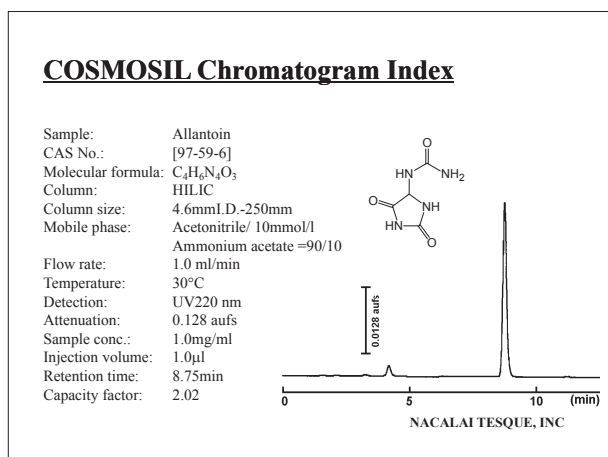

Ordering Information

● Analytical / Preparative Column (Particle Size: 5 µm)

COSMOSIL HILIC Packed Column

Column Size I.D. x Length (mm)	Product Number	Column Size I.D. x Length (mm)	Product Number
1.0 x 150	07869-11	4.6 x 150	07056-51
1.0 x 250	07870-71	4.6 x 150 3 lots set*	09385-23
2.0 x 30	08568-21	4.6 x 250	07057-41
2.0 x 50	07052-91	10 x 250	07059-21
2.0 x 100	08569-11	20 x 250	07060-81
2.0 x 150	07054-71	28 x 250	07875-21
2.0 x 250	07489-91		
3.0 x 150	07871-61		
3.0 x 250	07872-51		

*For 4.6 x 150 3 lots set, please refer to page 11.

COSMOSIL HILIC Guard Column

Column Size I.D. x Length (mm)	Product Number
4.6 x 10	07055-61
10 x 20	07058-31
20 x 20	07854-91
20 x 50	07873-41
28 x 50	07874-31

8. Mono- and Oligosaccharide Analysis Columns

Introduction

Saccharides are not retained on standard C₁₈ columns because of the low hydrophobicity of compounds. COSMOSIL Sugar-D and NH₂-MS are specifically designed for separation of saccharides. COSMOSIL C₁₈-PAQ is recommended for hydrophobic glycosides or saccharide derivatives.

Specifications

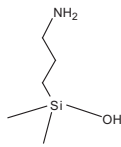
Packing Material	Sugar-D	NH ₂ -MS
Silica Gel	High Purity Porous Spherical Silica	
Average Particle Size	5 μm	
Average Pore Size	—	approx. 120 Å
Specific Surface Area	—	approx. 300 m ² /g
Bonded Phase Structure	—	
Bonded Phase	Secondary/Tertiary Amine	Aminopropyl Group
Bonding Type	—	Polymeric
Object Substances	Monosaccharides, Oligosaccharides	
End-capping Treatment	—	Near-perfect Treatment
Carbon Load	—	approx. 4%
Features	<ul style="list-style-type: none"> • First choice of saccharide analysis • High durability • Good quantitative analysis 	<ul style="list-style-type: none"> • Different selectivity from Sugar-D

Comparison of Retention

The conventional aminopropyl column is slightly more retentive than Sugar-D. The retention time can be adjusted by increasing the concentration of acetonitrile in the mobile phase by 5%–10%

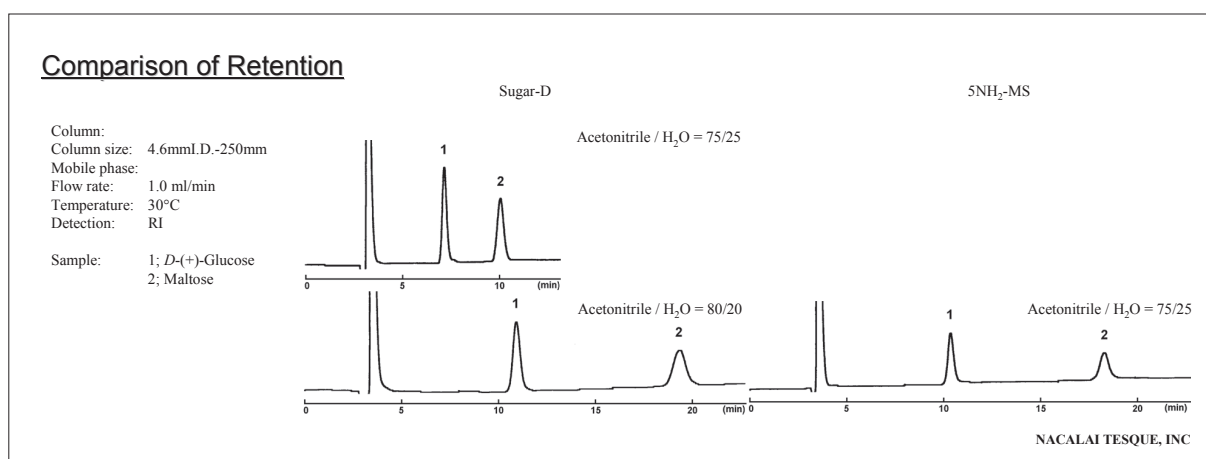

COSMOSIL Sugar-D

- Novel stationary phase for saccharides
- Superior durability to conventional amino columns
- Minimized undesirable adsorption

Comparison of Durability

The decrease of retention time was compared between COSMOSIL Sugar-D and conventional aminopropyl bonded stationary phase under severe condition of 100% water as eluent between tests. The capacity factor did not decrease in case of COSMOSIL Sugar-D.

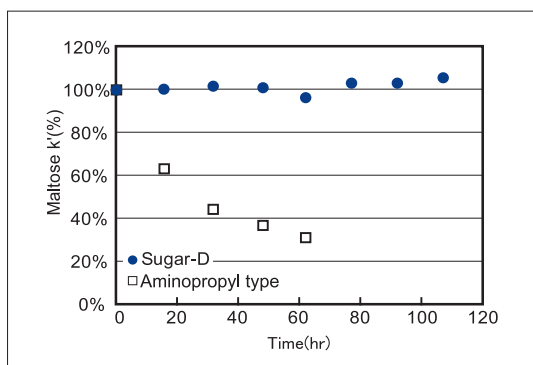

Decomposition Condition
 Solution Water
 Flow Rate 1.0 ml/min
 Temperature Room Temperature
 Column 4.6 mm I.D. x 250 mm
 Mobile Phase Acetonitrile : Water = 70 : 30
 Flow Rate 1.0 ml/min
 Temperature 30°C
 Detection RI
 Sample Maltose

Comparison of Adsorption

Certain types of saccharides such as arabinose or galactose are partially or temporarily adsorbed on conventional aminopropyl stationary phases causing tailing or no elution at all. COSMOSIL Sugar-D provides superior separation and high recovery for these saccharides.

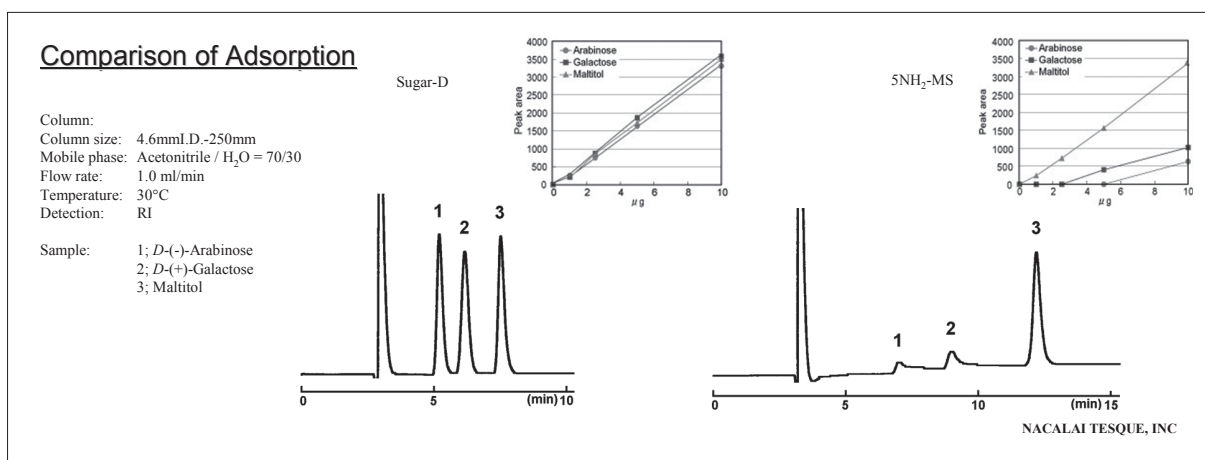

Applications

• Mono- and Oligosaccharides

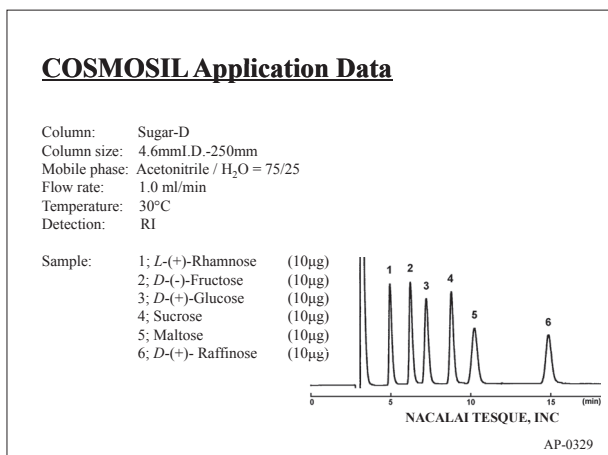

• Polyols

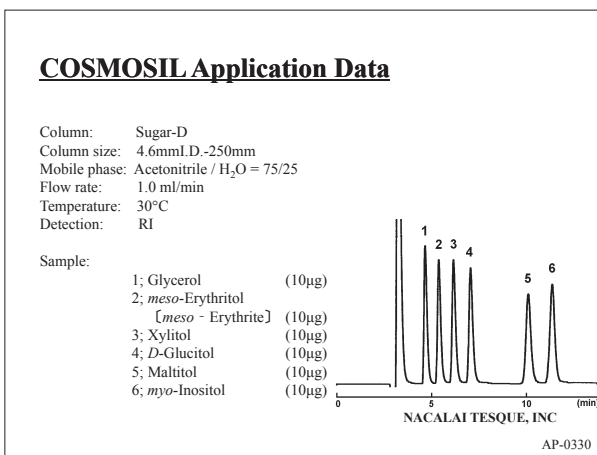

Applications

●Oligomaltoses

COSMOSIL Application Data

Column: Sugar-D
 Column size: 4.6mmI.D.-250mm
 Mobile phase: Acetonitrile / H₂O = 65/35
 Flow rate: 1.0 ml/min
 Temperature: 30°C
 Detection: RI

Sample:

- 1; D-(+)-Glucose (10µg)
- 2; Maltose (10µg)
- 3; Maltotriose (10µg)
- 4; Maltotetraose (10µg)
- 5; Maltopentaose (10µg)
- 6; Maltohexaose (10µg)
- 7; Maltoseptaose (10µg)

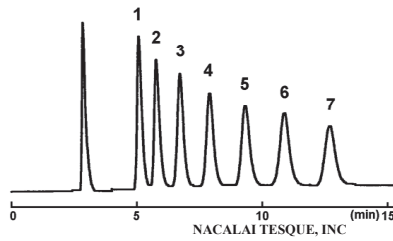

NACALAI TESQUE, INC

AP-0331

●Oligofructoses

COSMOSIL Application Data

Column: Sugar-D
 Column size: 4.6mmI.D.-250mm
 Mobile phase: Acetonitrile / H₂O = 70/30
 Flow rate: 1.0 ml/min
 Temperature: 30°C
 Detection: RI

Sample:

- Fructooligosaccharides (50µg)
- 1; L-Kestose
- 2; Nystose
- 3; L-Fructofuranosyl-D-nystose

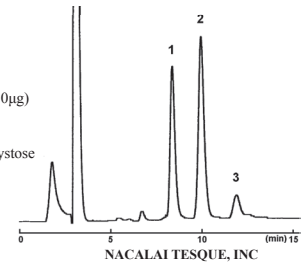

NACALAI TESQUE, INC

AP-0320

●Sweeteners

COSMOSIL Application Data

Column: Sugar-D
 Column size: 4.6mmI.D.-250mm
 Mobile phase: Acetonitrile/ H₂O = 85/15
 Flow rate: 1.0 ml/min
 Temperature: 30°C
 Detection: UV210nm

Sample:

- 1; Stevioside
- 2; Rebaudioside A

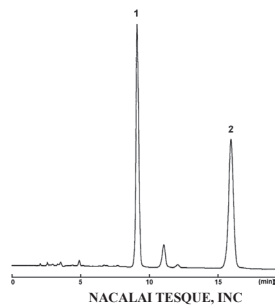

NACALAI TESQUE, INC

AP-1194

●Amino sugars

COSMOSIL Application Data

Column: Sugar-D
 Column size: 4.6mmI.D.-250mm
 Mobile phase: Acetonitrile/ 20mmol/l Phosphate buffer(pH7) = 70/30
 Flow rate: 1.0 ml/min
 Temperature: 30°C
 Detection: RI

Sample:

- 1; D-(+)-Mannose (10µg)
- 2; D-Mannosamine (10µg)

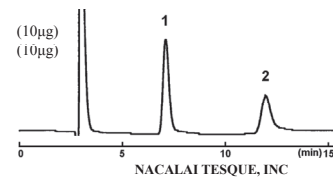

NACALAI TESQUE, INC

AP-0333

Comparison with Other Company Columns

The separation and the adsorption of monosaccharides were compared using COSMOSIL Sugar-D and other companies columns. Separation of aldoses, containing aldehyde group per molecule, is usually problematic with undesirable adsorption. COSMOSIL Sugar-D provides excellent separations for these saccharides.

Comparison

Column: Sugar-D
 Column size: 4.6mmI.D.-250mm
 Mobile phase: (Sugar-D, E Company) Acetonitrile / H₂O = 80/20
 (Others) Acetonitrile / H₂O = 75/25
 Flow rate: 1.0 ml/min
 Temperature: 30°C
 Detection: RI

- Sample:
- 1; L-(+)-Rhamnose (10 µg)
 - 2; D-(+)-Xylose (10 µg)
 - 3; D-(-)-Fructose (10 µg)
 - 4; D-(+)-Mannose (10 µg)
 - 5; D-(+)-Glucose (10 µg)

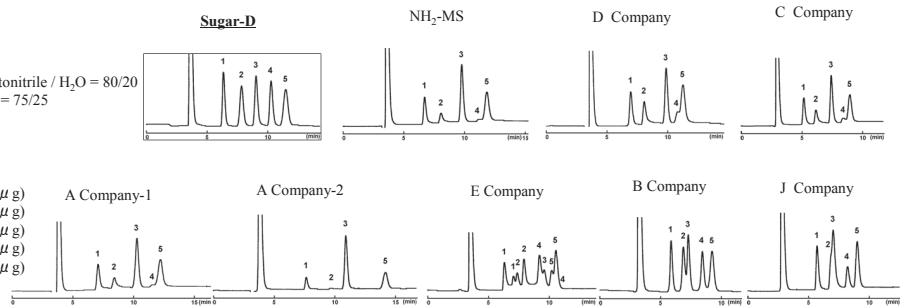

NACALAI TESQUE, INC

9. Protein Separation Columns

(1) Reversed Phase Chromatography

COSMOSIL Protein-R

- Excellent separation
- High recovery rate
- Outstanding stability at low pH

Specifications

Packing Material	Protein-R
Silica Gel	High Purity Porous Spherical Silica
Average Particle Size	5 μm
Average Pore Size	approx. 300 \AA
Specific Surface Area	approx. 150 m^2/g
Bonded Phase	Octadecyl Group
Bonding Type	Polymeric
Main Interaction	Hydrophobic Interaction
End-capping Treatment	Near-perfect Treatment
Features	<ul style="list-style-type: none"> • High recovery rate • Acid-resistant

Comparison of Separation

Protein-R shows sharper peaks for proteins than conventional C_{18} wide pore columns.

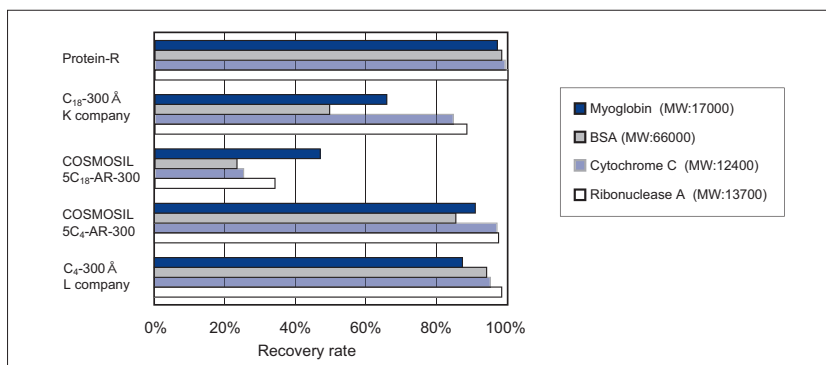
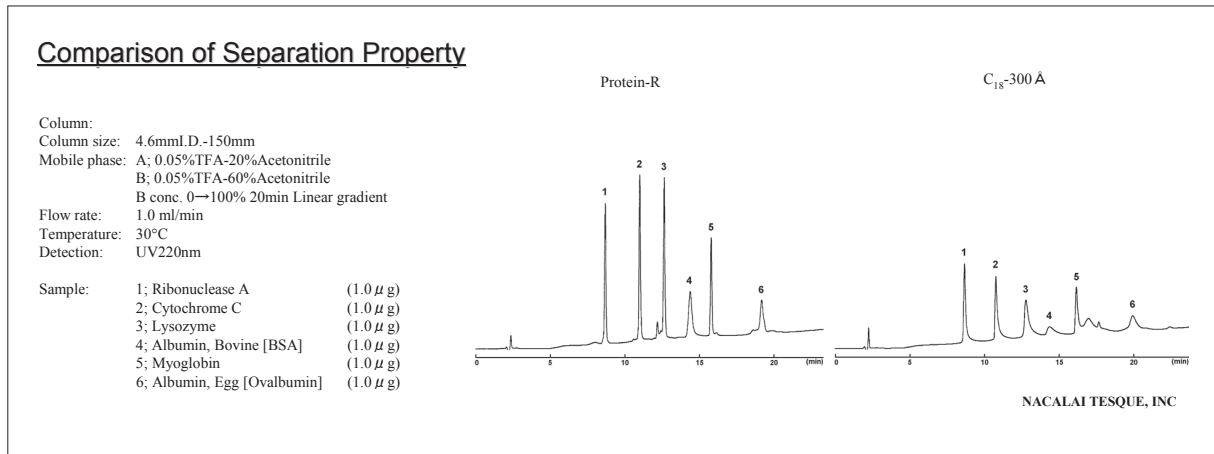

Recovery Rate

The figure left shows recovery rates for proteins using different columns. Protein-R shows a higher recovery rate than C_4 -300 and a much higher recovery rate than C_{18} -300.

Comparison of Durability Against Acidic Mobile Phase

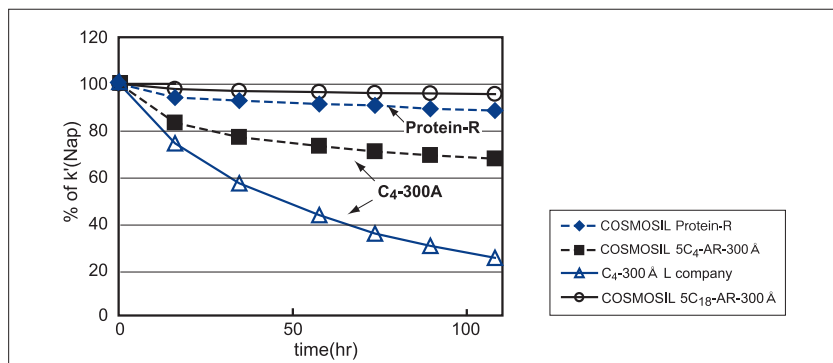

Degradation test with 0.1%–Trifluoroacetic Acid at 60°C
(k'): Napthalene in the mobile phase (Methanol : Water = 50 : 50)

The figure left shows durability against acidic mobile phase of various columns. Protein–R shows a higher acid durability than C₄–300.

Application of Peptide Separation

5C₁₈–MS–II (pore size 120 Å) shows better separation of low–molecular weight proteins, but Protein–R shows better separation of high–molecular weight proteins.

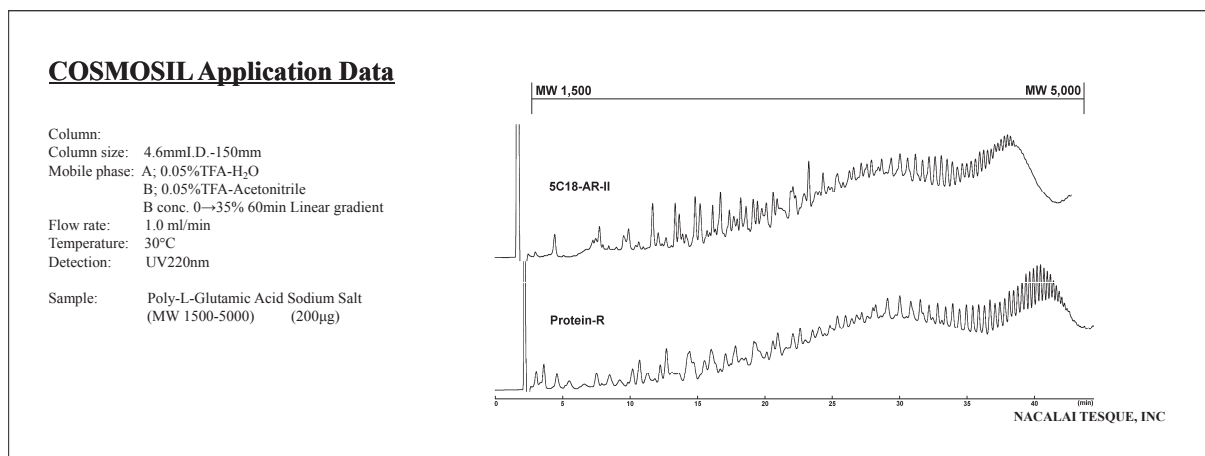

Ordering Information

- Analytical / Preparative Column (Particle Size: 5 µm)

COSMOSIL Protein–R Packed Column

Column Size I.D. x Length (mm)	Product Number	Column Size I.D. x Length (mm)	Product Number
2.0 x 150	06514–71	10 x 150	06529–91
4.6 x 50	06525–31	10 x 250	06530–51
4.6 x 150	06526–21	20 x 150	06531–41
4.6 x 250	06527–11	20 x 250	06532–31

COSMOSIL Protein–R Guard Column

Column Size I.D. x Length (mm)	Product Number
4.6 x 10	06518–31
10 x 20	06528–01
20 x 20	08692–81

COSMOSIL C₁₈-AR-300, C₈-AR-300, C₄-AR-300, Ph-AR-300

- Wide pore reversed phase column
- 4 types of phases (octadecyl, octyl, butyl and phenyl)

Specifications

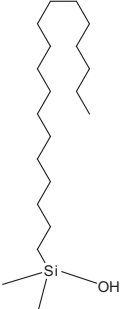
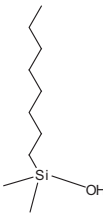
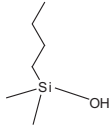
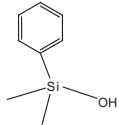
Packing Material	5C ₁₈ -AR-300	5C ₈ -AR-300	5C ₄ -AR-300	5Ph-AR-300
Silica Gel	High Purity Porous Spherical Silica			
Average Particle Size	5 μm			
Average Pore Size	approx. 300 Å			
Specific Surface Area	approx. 150 m ² /g			
Bonded Phase Structure				
Bonded Phase	Octadecyl Group	Octyl Group	Butyl Group	Phenyl Group
Bonding Type	Polymeric			
Main Interaction	Hydrophobic Interaction			Hydrophobic Interaction π-π Interaction
End-capping Treatment	Near-perfect Treatment			
Carbon Load	approx. 12%	approx. 7%	approx. 6%	approx. 7%

Comparison of Separation

COSMOSIL AR-300 packed column series offer 3 types of alkyl phases and a phenyl phase.

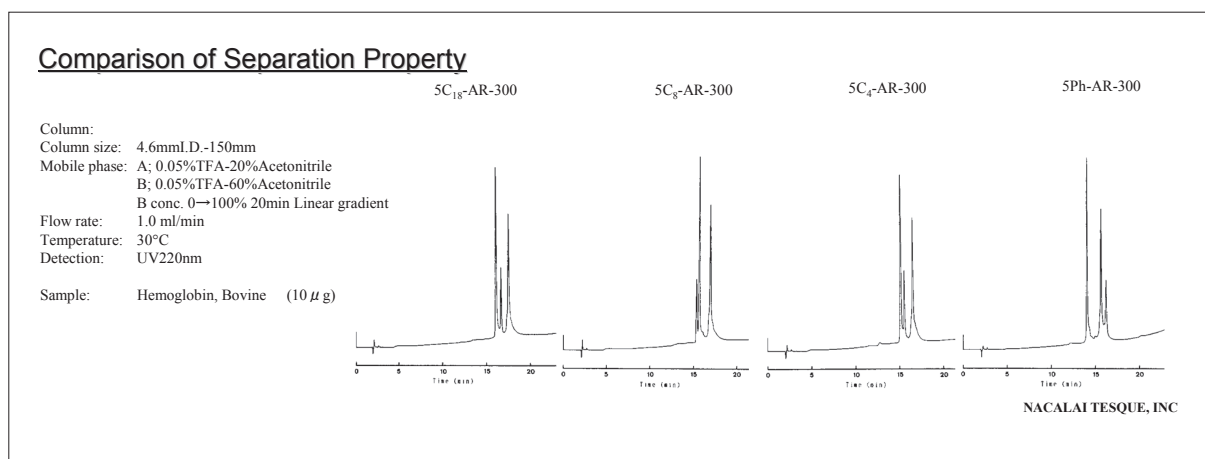

COSMOSIL Application Data

Column: 4.6mm I.D. -150mm
 Mobile phase: A: 0.05%TFA-20%Acetonitrile
 B: 0.05%TFA-60%Acetonitrile
 B conc. 0→100% 20min Linear gradient
 Flow rate: 1.0 ml/min
 Temperature: 30°C
 Detection: UV220nm, 0.64AUFS

Sample:
 1; Insulin (1.5µg)
 2; Trypsinogen (6.0µg)
 3; Transferrin (4.0µg)
 4; Trypsin Inhibitor (5.0µg)
 5; α-Chymotrypsinogen A (4.0µg)
 6; Carbonic Anhydrase (3.0µg)

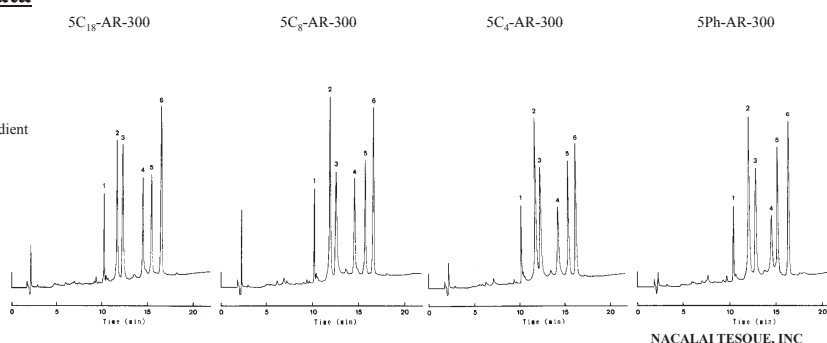
**Ordering Information**

- Analytical / Preparative Column (Particle Size: 5 µm)

COSMOSIL 5C₁₈-AR-300 Packed Column

Column Size I.D. x Length (mm)	Product Number
4.6 x 50	37911-01
4.6 x 150	37913-81
4.6 x 250	37914-71

COSMOSIL 5C₁₈-AR-300 Guard Column

Column Size I.D. x Length (mm)	Product Number
4.6 x 10	37910-11
10 x 20	37965-11

COSMOSIL 5C₈-AR-300 Packed Column

Column Size I.D. x Length (mm)	Product Number
4.6 x 50	37951-81
4.6 x 150	37953-61
4.6 x 250	37954-51

COSMOSIL 5C₈-AR-300 Guard Column

Column Size I.D. x Length (mm)	Product Number
4.6 x 10	37950-91
10 x 20	34464-61

COSMOSIL 5C₄-AR-300 Packed Column

Column Size I.D. x Length (mm)	Product Number
4.6 x 50	37956-31
4.6 x 150	37958-11
4.6 x 250	37959-01

COSMOSIL 5C₄-AR-300 Guard Column

Column Size I.D. x Length (mm)	Product Number
4.6 x 10	37955-41
10 x 20	05862-41

COSMOSIL 5Ph-AR-300 Packed Column

Column Size I.D. x Length (mm)	Product Number
4.6 x 50	37961-51
4.6 x 150	37963-31
4.6 x 250	37964-21

COSMOSIL 5Ph-AR-300 Guard Column

Column Size I.D. x Length (mm)	Product Number
4.6 x 10	37960-61
10 x 20	34268-41

Column Size I.D. x Length (mm)	Product Number
10 x 150	05865-11
10 x 250	34267-51
20 x 150	05866-01
20 x 250	34468-21

(2) Gel Filtration Chromatography Column (aqueous)

COSMOSIL Diol-120-II, Diol-300-II

- Ideal for the size-based separation of proteins and water soluble polymers
- Reduce undesirable adsorption

Specifications

Packing Material	5Diol-120-II	5Diol-300-II
Silica Gel	High Purity Porous Spherical Silica	
Average Particle Size	5 μm	
Average Pore Size	approx. 120 \AA	approx. 300 \AA
Bonded Phase	Diol Group	
Object Substance	Proteins, Water Soluble Polymers	
Flow Rate	0.5-1.0 (ml/min)	
Selection of Pore Size (protein)	5,000-100,000	10,000-700,000
Selection of Pore Size (water soluble polymers)	300-30,000	500-300,000

Calibration Curve

- Calibration Curve of Proteins

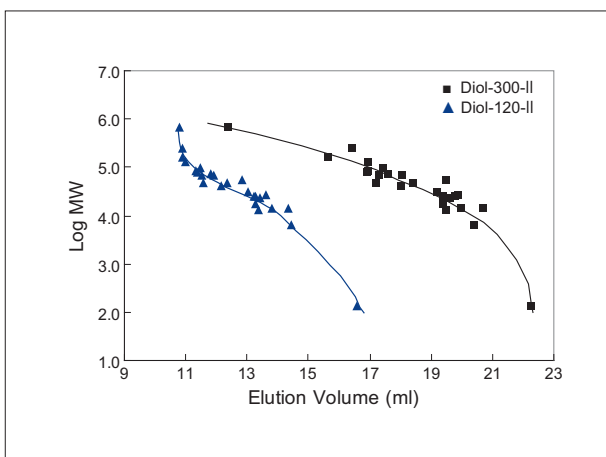

Column COSMOSIL 5Diol-II 7.5mm I.D. x 600 mm
 Mobile Phase 20mmol/l Phosphate Buffer (pH7.0)+100mmol/l Na₂SO₄
 Flow Rate 1.0ml/min
 Temperature 30°C

Sample	M.W.	Sample	M.W.
Thyroglobulin	660,000	Peroxidase	40,000
Catalase	250,000	Carbonic Anhydrase	30,000
Glucose Oxidase	160,000	α -Chymotrypsinogen A	25,700
Uricase	128,000	α -Chymotrypsin	25,200
Choline Oxidase	95,000	Trypsinogen	24,000
Transferrin	85,000	Trypsin (bovine)	23,300
Conalbumin	77,500	Myoglobin	17,000
Malate Dehydrogenase	70,000	Lysozyme	14,300
α -Glucosidase	68,500	Ribonuclease A	13,700
Albumin (BSA)	66,000	Cytochrome C	12,400
α -Amylase	52,500	Aprotinin	6,500
Fetuin	48,000	Gly-Gly	132
Albumin (Ovalbumin)	45,000		

Separation of Standard Proteins

COSMOSIL Diol-II series are available in two different pore sizes, Diol-120-II and Diol-300-II. Combination of these two columns enables separation of a wide M.W. range of samples.

Comparison of Separation Property

Column: 7.5mm I.D.-600mm
 Column size: 7.5mm I.D.-600mm
 Mobile phase: 20mmol/l Phosphate buffer(pH 7.0)
 + 100mmol/l Na₂SO₄
 Flow rate: 1.0 ml/min
 Temperature: Room temperature
 Detection: UV220nm

Sample: 1; Thyroglobulin
 2; Glucose Oxidase
 3; Conalbumin
 4; Peroxidase
 5; Myoglobin
 6; Aprotinin

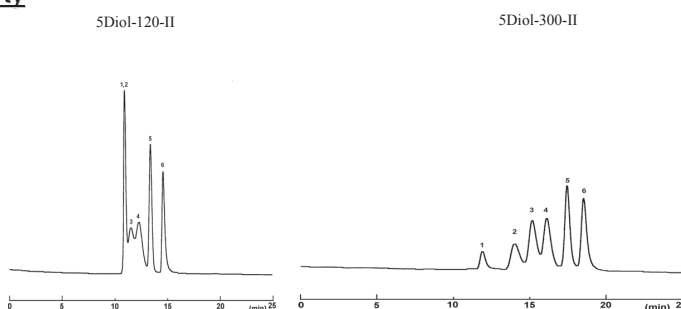

NACALAI TESQUE, INC

Comparison with Other Company Columns

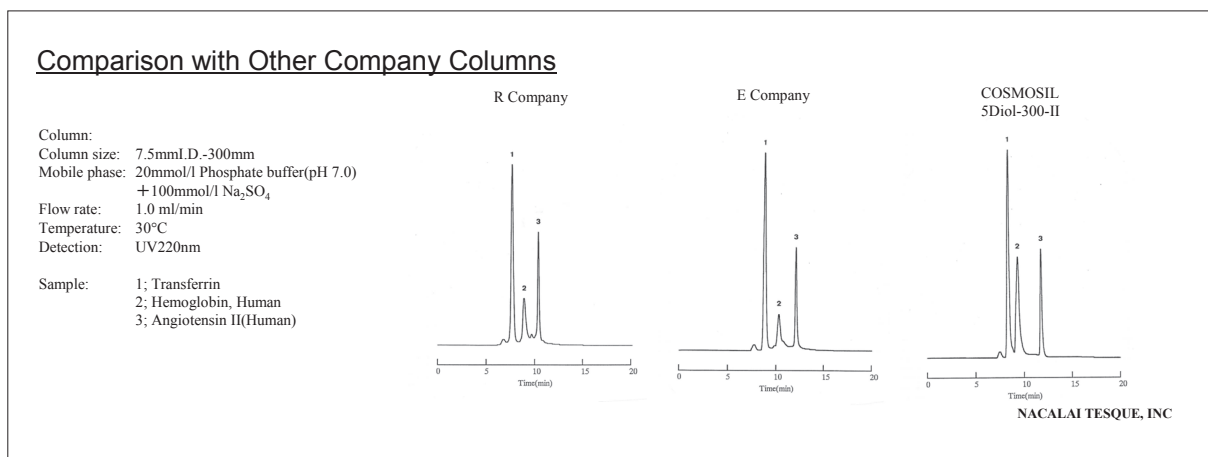

Applications

• Human Serum

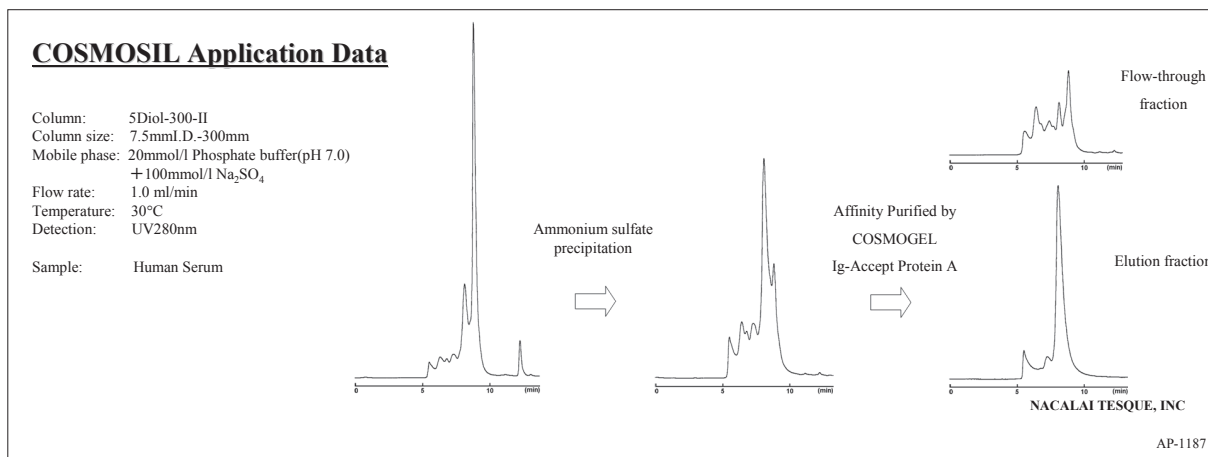

Ordering Information

• Analytical / Preparative Column (Particle Size: 5 μm)

COSMOSIL 5Diol-120-II Packed Column

Column Size I.D. x Length (mm)	Product Number
7.5 x 300	38050-51
7.5 x 600	38051-41

COSMOSIL 5Diol-120-II Guard Column

Column Size I.D. x Length (mm)	Product Number
7.5 x 50	38049-91

COSMOSIL 5Diol-300-II Packed Column

Column Size I.D. x Length (mm)	Product Number
7.5 x 300	38053-21
7.5 x 600	38054-11

COSMOSIL 5Diol-300-II Guard Column

Column Size I.D. x Length (mm)	Product Number
7.5 x 50	38052-31

(3) Ion Exchange Chromatography Column

COSMOGEL IEX Series

- Available in 3 different ion-exchange modes (Anion-exchange type, Cation-exchange type, Amphoteric ion-exchange type)
- Available for 3 different application areas (for Purification, for Ultra-fast analysis, for Precise analysis)
- For separation of biopolymers such as proteins or nucleic acids

Specifications

Packing Material	Type Q	Type Q-N	Type S	Type S-N	Type M	Type M-N
Gel/Average Particle Size	Totally Porous Spherical Hydrophilic Polymer / 5 µm					
Average Pore Size	1000 Å	Non-porous	1000 Å	Non-porous	1000 Å	Non-porous
Functional Group	-CH ₃ N ⁺ (CH ₃) ₃		-(CH ₂) ₃ SO ₃ ⁻		-CH ₃ N ⁺ (CH ₃) ₃ + -(CH ₂) ₃ SO ₃ ⁻	
Protein Binding Capacity	110-150 mg	12-20 mg	70-100 mg	10-18 mg	55-75 mg(BSA)/ml 35-50 mg(IgG)/ml	6-10 mg(BSA)/ml 5-9 mg(IgG)/ml
Column Size I.D. x Length (mm)	4.6-50	4.6-30 / 4.6-100	4.6-50	4.6-30 / 4.6-100	4.6-50	4.6-100
Column Material	PEEK					
Connection	Waters Type					

Type of Packing Material

COSMOGEL IEX Series are available in amphoteric ion-exchange type in which two kinds of packing materials are mixed, as well as in widely used anion-exchange type and cation-exchange type.

Type of Packing Material	Target Sample	Average Pore Size	
		Porous (1000 Å)	Non-porous
Anion-exchange Type	Acidic Proteins / DNA	Type Q	Type Q-N
Cation-exchange Type	Basic Proteins	Type S	Type S-N
Amphoteric ion-exchange Type	All Proteins	Type M	Type M-N

- Comprehensive isolation of proteins by Amphoteric ion-exchange type (Type M)

The amphoteric ion-exchange type enables the simultaneous separation of both acidic and basic proteins in one application.

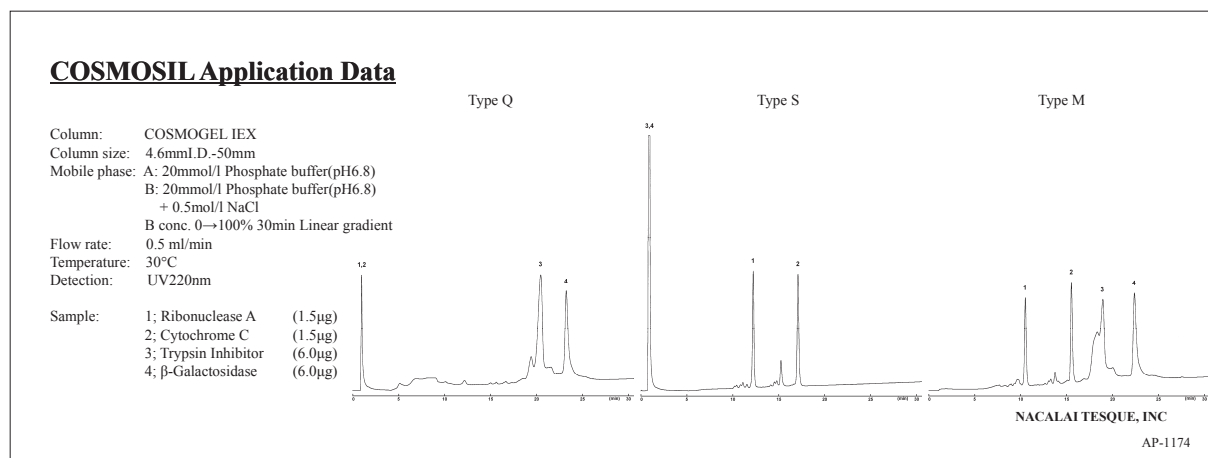

Type of Column

COSMOGEL IEX Series are available for 3 types of applications:

Application	Pore Size	Column Size I.D. x Length (mm)	Column		
For Purification	Porous (1000 Å)	4.6-50	Type Q	Type S	Type M
For Precise Analysis	Non-porous	4.6-100	Type Q-N	Type S-N	Type M-N
For Ultra-fast Analysis	Non-porous	4.6-30	Type Q-N	Type S-N	—

- For Purification: Type Q, Type S, Type M

The type of porous packing materials have higher binding capacity of proteins than the respective non-porous type, which means that peak shape does not spread even with injection of a large volume of sample. Therefore they are highly suitable for purification of large sample.

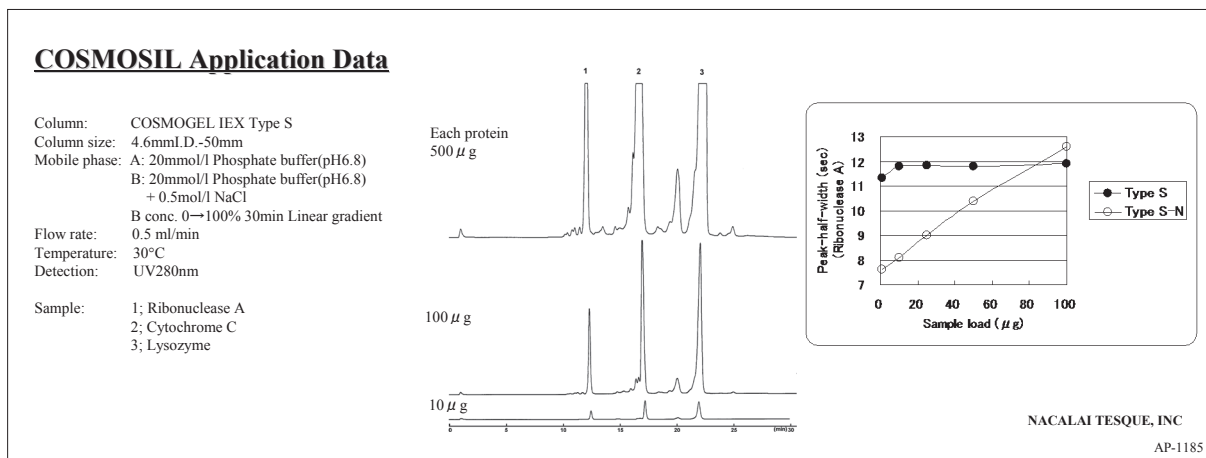

- For Precise Analysis: Type Q-N, Type S-N, Type M-N

The type of non-porous packing materials reduce spreading of samples in packing materials, result in high resolution separation for precise analysis such as quality control of antibody drugs. The longer column length also contributes to the sharper peaks.

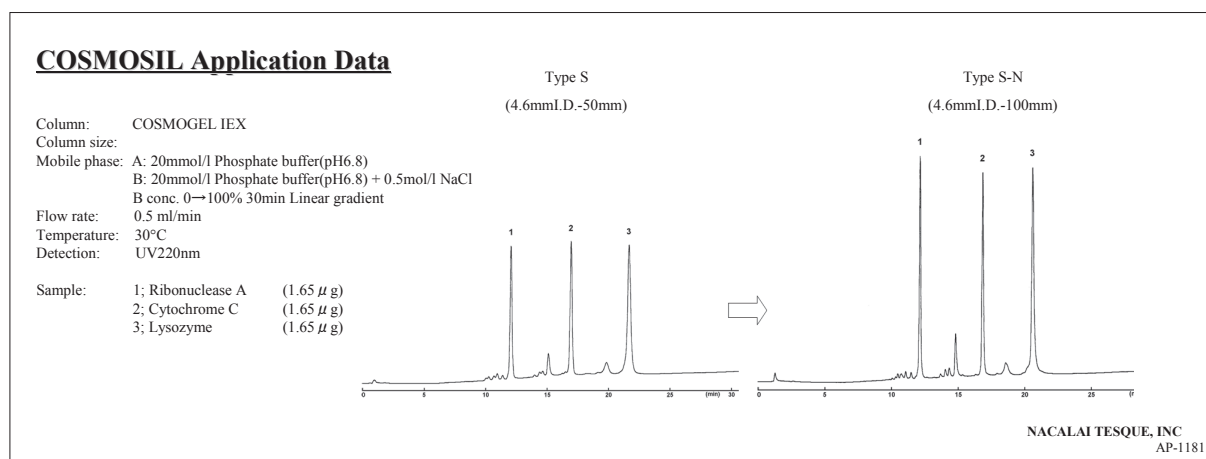

- For Ultra-fast Analysis: Type Q-N, Type S-N

The type of non-porous packing materials is not much affected by high flow rate and thus the materials are suitable for fast analysis. The shorter column length contributes to the fast analysis.

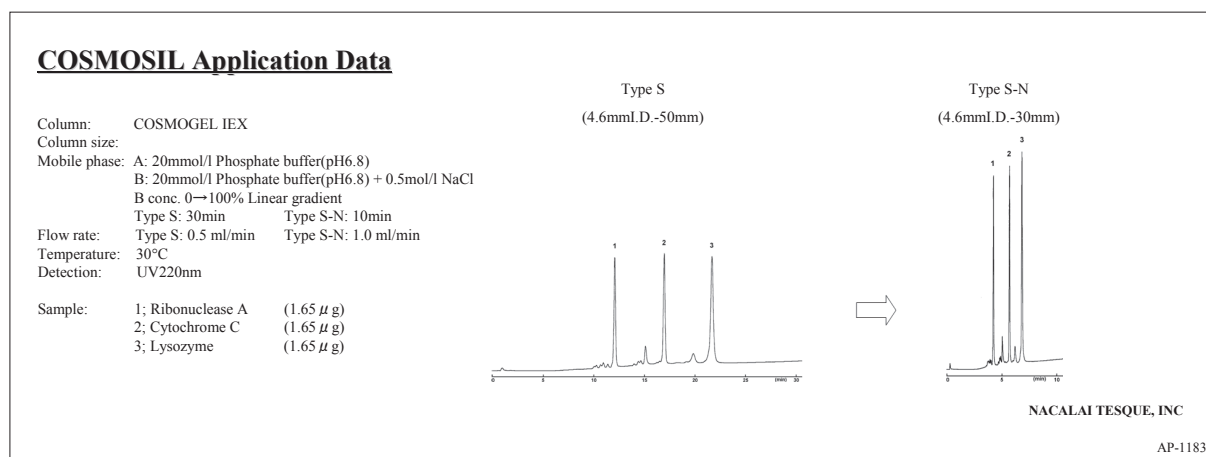

Applications

• Performance Comparison

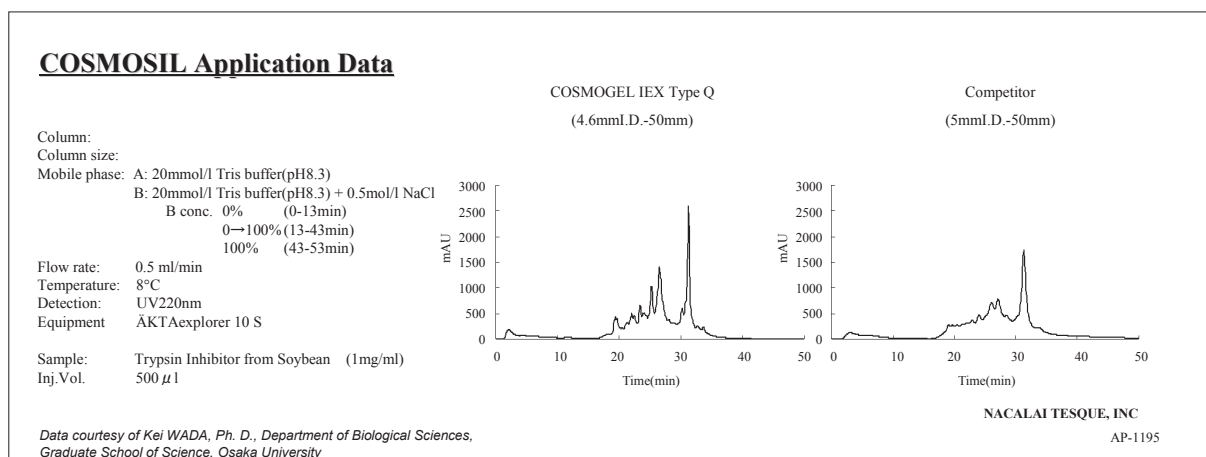

• Purification of His-tag Fusion Proteins

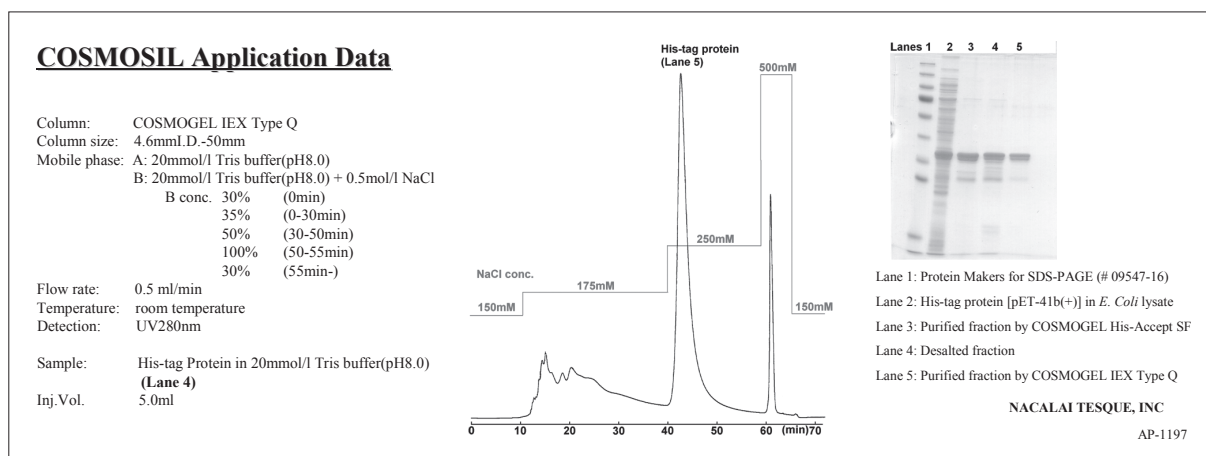

Ordering Information

Ion Exchange Mode	Product Name	Application	Column Size I.D. x Length (mm)	Product Number
Anion-exchange Type	COSMOGEL IEX Type Q	For Purification	4.6 x 50	06266-31
	COSMOGEL IEX Type Q-N	For Ultra-fast Analysis	4.6 x 30	06264-51
	COSMOGEL IEX Type Q-N	For Precise Analysis	4.6 x 100	06258-41
Cation-exchange Type	COSMOGEL IEX Type S	For Purification	4.6 x 50	06252-01
	COSMOGEL IEX Type S-N	For Ultra-fast Analysis	4.6 x 30	06251-11
	COSMOGEL IEX Type S-N	For Precise Analysis	4.6 x 100	06250-21
Amphoteric Ion-exchange Type	COSMOGEL IEX Type M	For Purification	4.6 x 50	06248-71
	COSMOGEL IEX Type M-N	For Precise Analysis	4.6 x 100	06244-11

COSMOSIL HIC

- Separate based on differences in hydrophobicity
- Little loss in enzyme activity and the tertiary structure of proteins

Specifications

Packing Material	HIC
Silica Gel	High Purity Porous Spherical Silica
Average Particle Size	5 μm
Average Pore Size	approx. 300 \AA
Specific Surface Area	approx. 150 m^2/g
Main Interaction	Hydrophobic Interaction

Applications

A buffer with high salt concentration, usually 1–2 mol/l of $(\text{NH}_4)_2\text{SO}_4$, is used as an initial mobile phase for adsorption of samples to a weakly hydrophobic stationary phase. The elution is done with a decreasing salt gradient. The application in lower left shows myoglobin elutes first than BSA under the buffer with high salt concentration, suggesting that myoglobin is less hydrophobic than BSA.

• Separation of Protein Standards

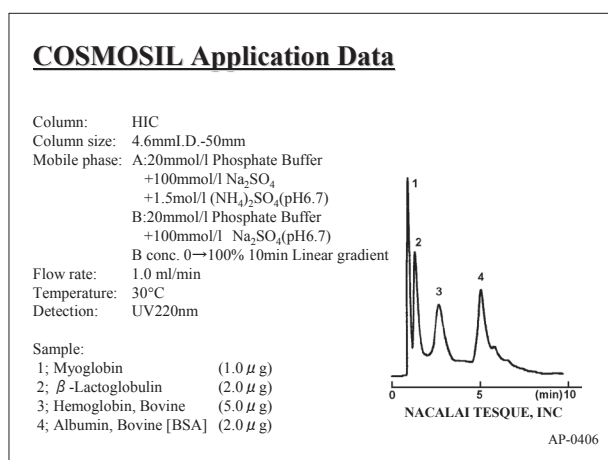

• Separation of β -Glucosidase

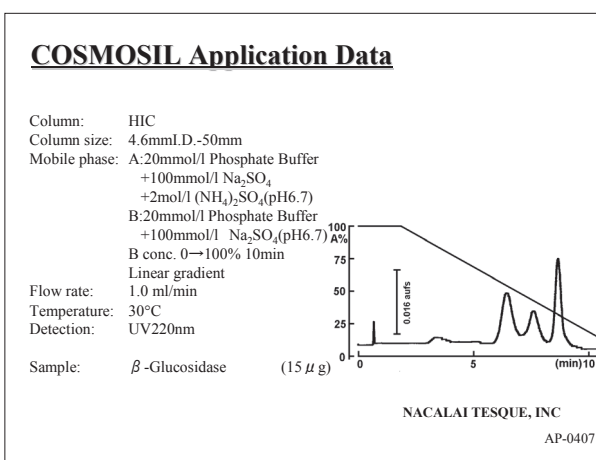

Ordering Information

- Analytical / Preparative Column (Particle Size: 5 μm)

COSMOSIL 5HIC Packed Column

Column Size I.D. x Length (mm)	Product Number
4.6 x 50	04263-21

10. Columns for Fullerene Separation

Introduction

Separation of fullerenes, especially preparative scale separation, on conventional HPLC columns are always problematic due to the low solubility and low recovery rate of fullerenes. COSMOSIL offers a variety of columns designed for preparative scale separation of fullerenes including higher fullerenes, metallofullerenes and fullerene derivatives.

Specifications

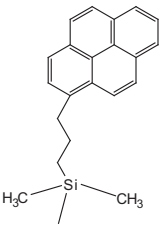
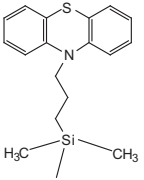
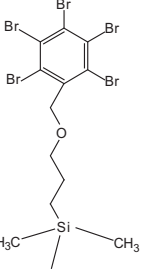
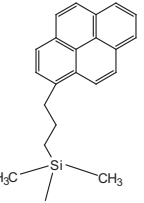
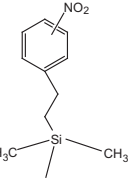
Packing Material	Buckyprep	Buckyprep-M	PBB	PYE	NPE
Silica Gel	High Purity Porous Spherical Silica				
Average Particle Size	5 μm				
Average Pore Size	approx. 120 \AA				
Specific Surface Area	approx. 300 m^2/g				
Bonded Phase Structure					
Bonded Phase	Pyrenylpropyl Group	Phenothiazinyl Group	Pentabromobenzyl Group	Pyrenylethyl Group	Nitrophenylethyl Group
Bonding Type	Monomeric				
End-capping Treatment	Near-perfect Treatment	None	Near-perfect Treatment		
Carbon Load	approx. 17%	approx. 13%	approx. 8%	approx. 18%	approx. 9%
Features	• Standard column for fullerene separation.	• Designed to separate metallofullerenes	• Designed for preparative separation of C_{60} , C_{70}	• Separation of fullerene and structural isomers	• Separation of fullerene derivatives

Comparison of Retention

The figure below shows the retention time of C_{60} and C_{70} in toluene. Buckyprep, Buckyprep-M and PBB, and PYE nicely separate C_{60} and C_{70} . On the other hand, C_{18} with alkyl group and NPE can not separate them in toluene.

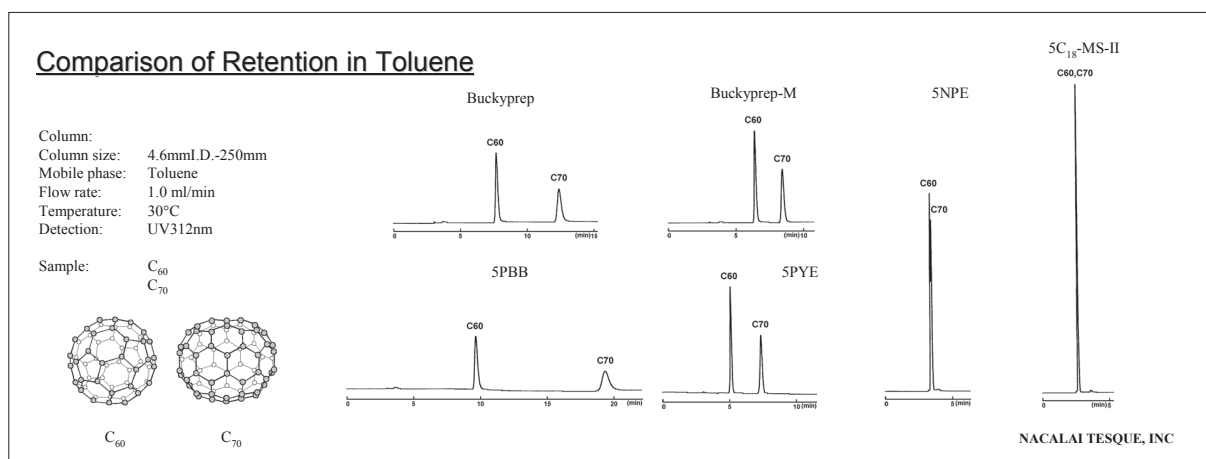

Solubility and Boiling Point of Each Solvent for C₆₀

Solubility and boiling point of each solvent for C₆₀

Solvent	mg/ml	b.p. (°C)
Methanol	0.001	64.5
Acetonitrile	0.018	81.8
n-Hexane	0.046	68.7
Toluene	3.2	111
Chlorobenzene*	7.0	132
Carbon disulfide	12	46.3
1,2,4-Trichlorobenzene	21.3	213
o-Dichlorobenzene*	27	180

*R.S.Ruoff, et al., *J. phy. Chem.*, 97, 3379 (1993)

The table on the left shows solubility and boiling point of each solvent for C₆₀. Toluene is the most suitable solvent for due to its high solubility, appropriate boiling point, low cost and low corrosivity. Although C₁₈ column with alkyl group can not separate C₆₀ and C₇₀ in toluene, by mixing acetonitrile and toluene, they can be separated as shown in the figure below. However, increase injection volume in preparative purification triggers tailing that result in practical injection volume limit of only 70 µl (175 µg). On the other hand, Buckyprep can separate well in toluene with non-tailing with the maximum injection volume of 2,500 µl (6.25 mg).

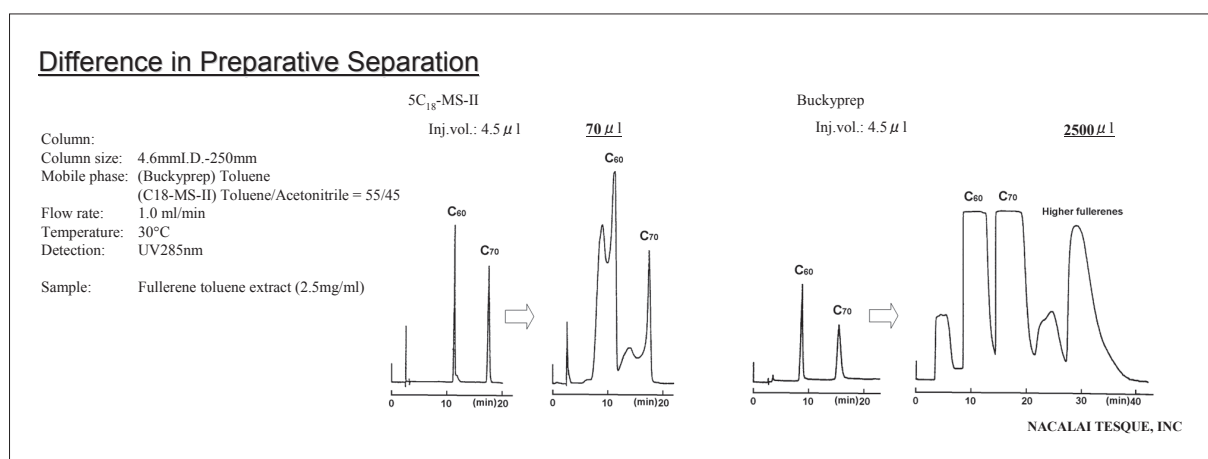

Suggested Solvents

• Features of suggested solvents for fullerene separation

Solvent	Feature
Chlorobenzene	Stronger the elution effect than toluene. Recommended for higher fullerenes.
o-Dichlorobenzene	Stronger the elution effect than chlorobenzene. Excellent solubility for fullerenes.
1,2,4-Trichlorobenzene	The strongest elution effect. It is suitable not only for mobile phase but also for washing solution for adsorbed higher fullerenes. In case of injecting continuously for high purity, recommend to wash the columns each purification . (4.6 mm I.D. x 250 mm) injection volume for washing: approx. 3ml (20 mm I.D. x 250 mm) injection volume for washing: approx. 50ml
Hexane	Weak elution effect. Recommended for weakly retained fullerenes.
Acetonitrile	Weak elution effect. Recommended for weakly retained fullerenes.

Note: Use them after filtration or distillation, if they are not for HPLC.

Except for alkali aqueous and strong acid solutions, other solvents can be used (water-free pyridine and others). Depending on solvents, pay attention to high pressure caused by high solvent viscosity.

COSMOSIL Buckyprep

- Standard column for fullerene separation
- Excellent separation for higher and derivatized fullerenes

Applications

• Higher Fullerenes

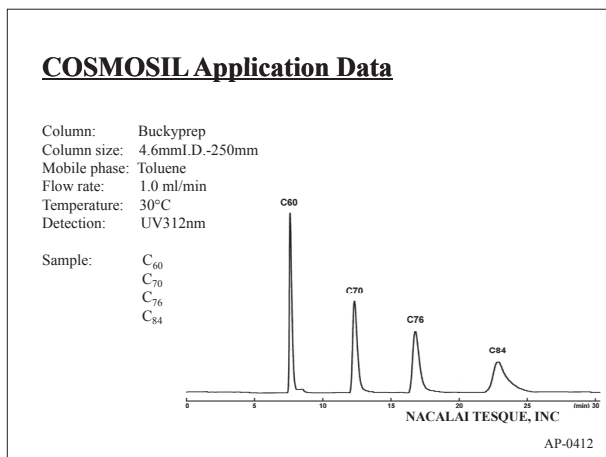

• Derivatized Fullerenes

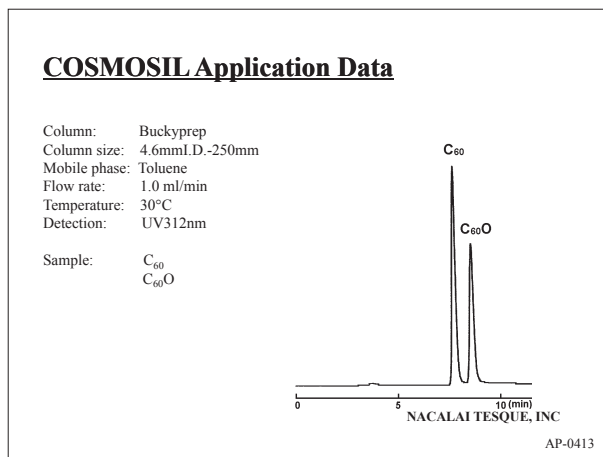

Fullerene Chromatogram Index

Fullerene Chromatogram Index includes more than 100 chromatograms. If you are interested in this index, please feel free to e-mail us at info.intl@nacalai.com. The online version is available at the website of The Fullerenes, Nanotubes and Graphene Research Society below.

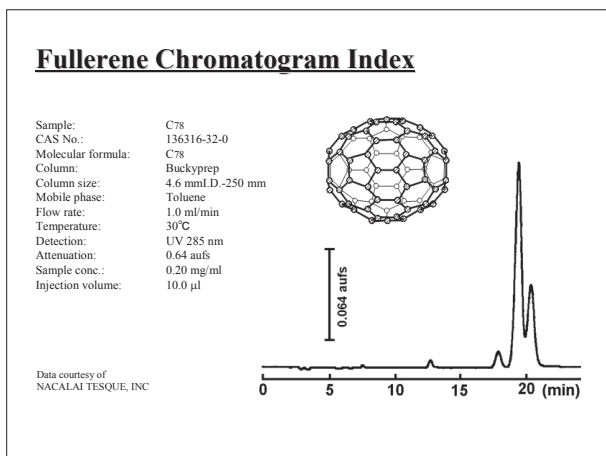

The Fullerenes, Nanotubes and Graphene Research Society
 Website: http://fullerene-jp.org/jp/chromato_index_3.pdf

Ordering Information

- Analytical / Preparative Column (Particle Size: 5 µm)

COSMOSIL Buckyprep Packed Column

COSMOSIL Buckyprep Guard Column

Column Size I.D. x Length (mm)	Product Number	Column Size I.D. x Length (mm)	Product Number
4.6 x 250	37977-61	4.6 x 10	37983-71
10 x 250	37981-91	10 x 20	37984-61
20 x 250	37982-81	20 x 50	34374-41
28 x 250	34346-11	28 x 50	05871-21

COSMOSIL Buckyprep-M

- Different selectivity with Buckyprep
- Excellent separation for metallofullerenes

Applications

• Metallofullerenes

COSMOSIL Buckyprep-M is a phenothiazinyl group bonded silica based column specifically designed for metallofullerene separation. Metallofullerenes are retained more strongly than other fullerenes on this column. COSMOSIL Buckyprep-M is also effective for the separation of higher fullerenes and fullerene derivatives.

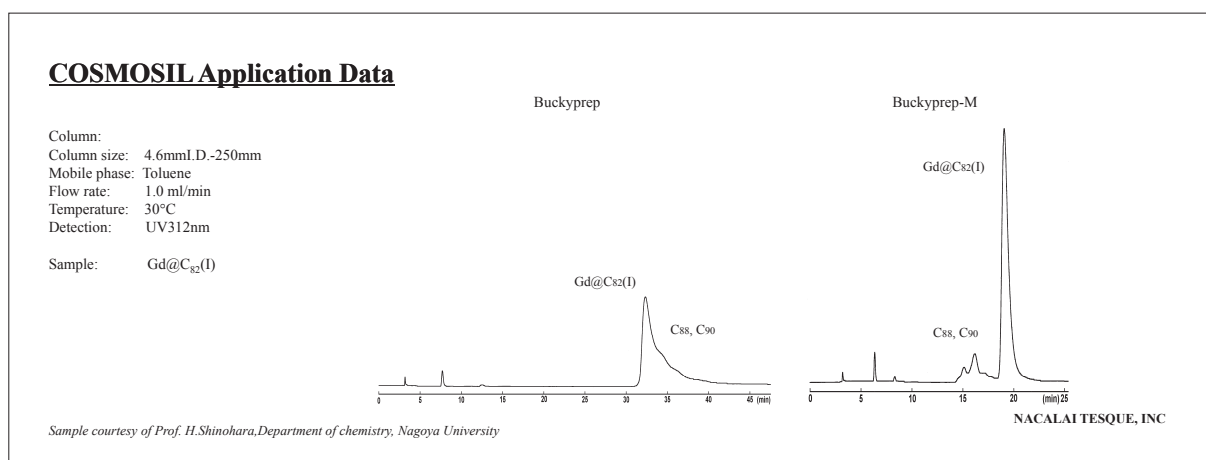
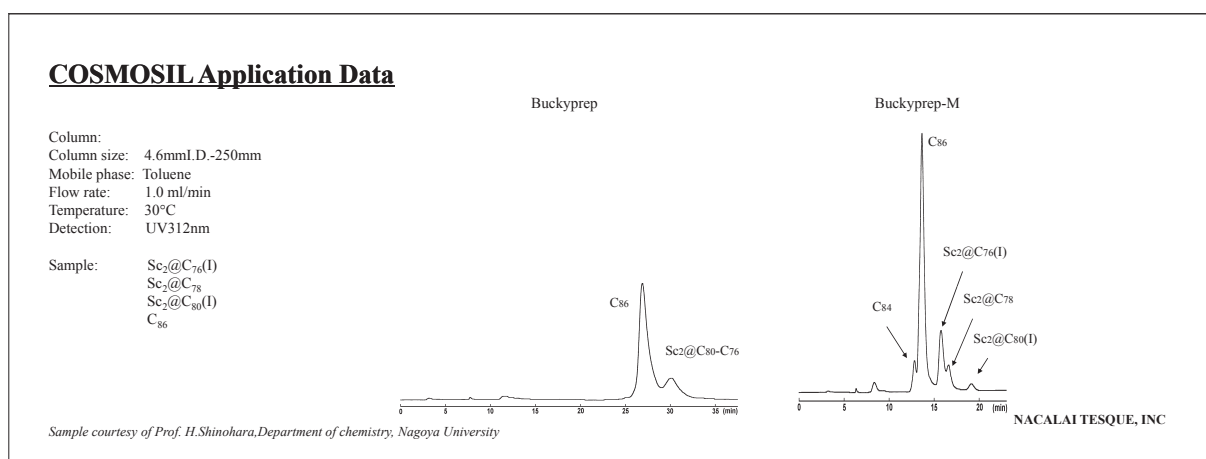

Ordering Information

- Analytical / Preparative Column (Particle Size: 5 μm)

COSMOSIL Buckyprep-M Packed Column

COSMOSIL Buckyprep-M Guard Column

Column Size I.D. x Length (mm)	Product Number	Column Size I.D. x Length (mm)	Product Number
4.6 x 250	04138-71	4.6 x 10	04139-61
10 x 250	04141-11	10 x 20	04140-21
20 x 250	04142-01	20 x 50	34474-31
28 x 250	05873-01	28 x 50	05872-11

COSMOSIL PBB

- Designed for preparative separation of fullerenes and higher fullerenes
- Can be used with *o*-dichlorobenzene or carbon disulfide
- Suitable for preparative scale separation

Separation of Fullerenes with Different Mobile Phases

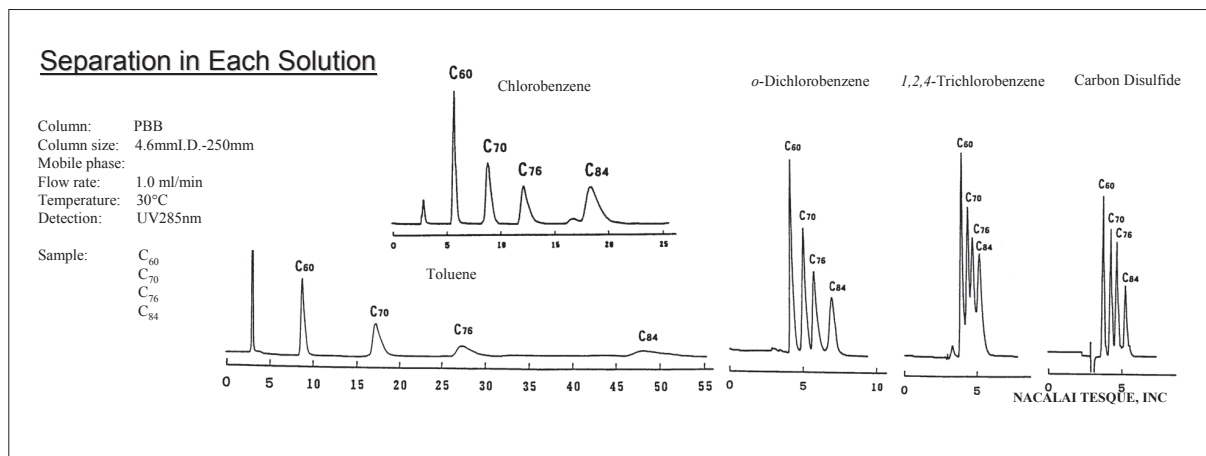

Preparative-scale Separation

The loading capacity of COSMOSIL PBB for C₆₀ and C₇₀ can be three times greater than COSMOSIL Buckyrep.

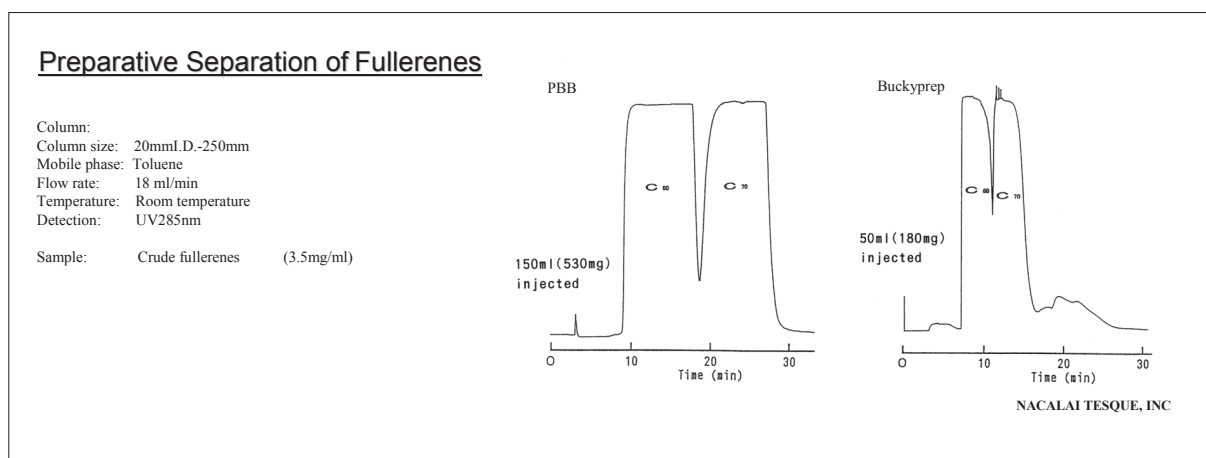

Ordering Information

- Analytical / Preparative Column (Particle Size: 5 µm)

COSMOSIL 5PBB Packed Column

COSMOSIL 5PBB Guard Column

Column Size I.D. x Length (mm)	Product Number	Column Size I.D. x Length (mm)	Product Number
4.6 x 250	37980-01	4.6 x 10	37987-31
10 x 250	37985-51	10 x 20	37988-21
20 x 250	37986-41	20 x 50	34375-31

COSMOSIL NPE

- Different selectivity from Buckyprep or PBB
- Excellent separation for derivatized fullerenes

Applications

- PCBM, PCBB

COSMOSIL NPE retains derivatized C₆₀ stronger than C₆₀.

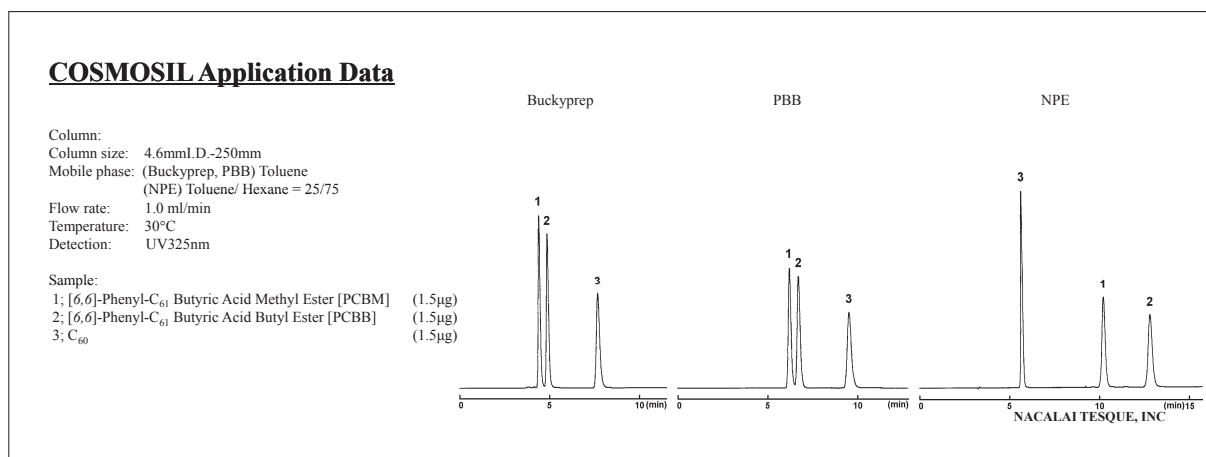

Need to add the Hexane into mobile phase due to weak retention effect.

Ordering Information

- Analytical / Preparative Column (Particle Size: 5 µm)

COSMOSIL 5NPE Packed Column

Column Size I.D. x Length (mm)	Product Number
4.6 x 150	37902-21
4.6 x 250	37990-71
10 x 250	05469-11
20 x 250	38046-21

COSMOSIL 5NPE Guard Column

Column Size I.D. x Length (mm)	Product Number
4.6 x 10	37904-01
10 x 20	38045-31
20 x 50	05869-71

COSMOSIL PYE

Ordering Information

- Analytical / Preparative Column (Particle Size: 5 µm)

COSMOSIL 5PYE Packed Column

Column Size I.D. x Length (mm)	Product Number
4.6 x 250	37989-11
10 x 250	37996-11
20 x 250	38044-41
28 x 250	34300-91

COSMOSIL 5PYE Guard Column

Column Size I.D. x Length (mm)	Product Number
4.6 x 10	37903-11
10 x 20	38041-71
20 x 50	34475-21

11. Columns for Soluble Carbon Nanotube Separation

COSMOSIL CNT-300, CNT-1000, CNT-2000

- Size-based separation of soluble carbon nanotubes
- Three types of pore size (300 Å, 1000 Å, 2000 Å)
- High durability

Specifications

Packing Material	CNT-300	CNT-1000	CNT-2000
Silica Gel	High Purity Porous Spherical Silica		
Average Particle Size	5 μm		
Average Pore Size	approx. 300 Å	approx. 1000 Å	approx. 2000 Å
Bonded Phase	Hydrophilic Group (neutral)		
pH Range	2.0-7.5		
Pressure	15MPa and below		

Applications

- Carbon nanotubes

COSMOSIL CNT columns offered improved separation for DNA wrapped carbon nanotubes by connecting three columns with different pore sizes.

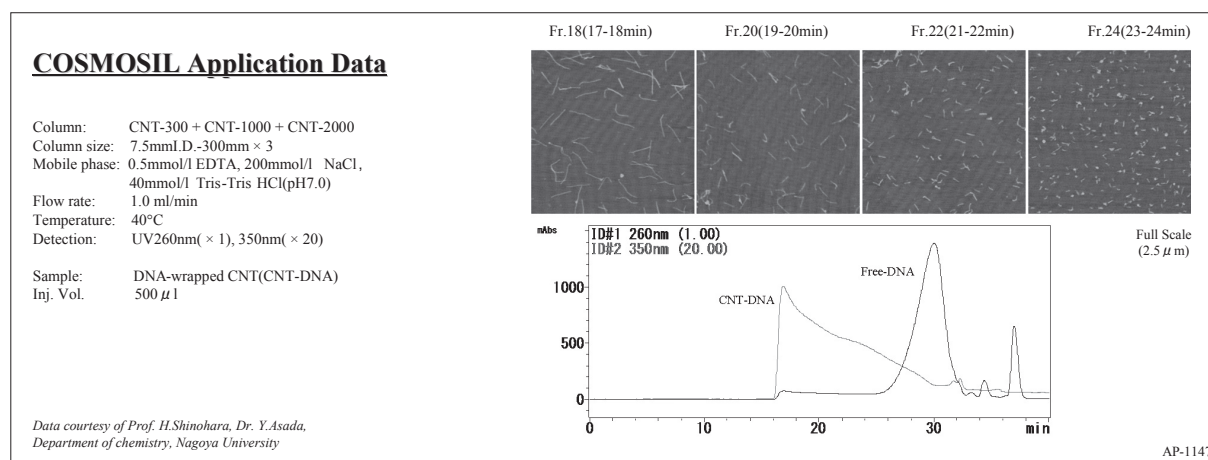

Ordering Information

- Analytical column (Particle Size: 5μm)

COSMOSIL CNT-300 Packed Column

Column Size I.D. x Length (mm)	Product Number
7.5 x 300	09195-71

COSMOSIL CNT-300 Guard Column

Column Size I.D. x Length (mm)	Product Number
7.5 x 50	09194-81

COSMOSIL CNT-1000 Packed Column

Column Size I.D. x Length (mm)	Product Number
7.5 x 300	09197-51

COSMOSIL CNT-1000 Guard Column

Column Size I.D. x Length (mm)	Product Number
7.5 x 50	09196-61

COSMOSIL CNT-2000 Packed Column

Column Size I.D. x Length (mm)	Product Number
7.5 x 300	09199-31

COSMOSIL CNT-2000 Guard Column

Column Size I.D. x Length (mm)	Product Number
7.5 x 50	09198-41

12. Conventional Columns

Introduction

A period of more than 32 years has passed since the first COSMOSIL 5C₁₈ columns were developed and offered for sale. Continuous technical improvement has made many of these columns obsolete and not of the highest quality and performance available any more. However, many long-term users continue to employ these older conventional columns for routine analysis and quality control. Nevertheless, the manufacture of these older columns will eventually cease and we strongly urge customers to replace the conventional columns with their higher performance equivalents outlined in the table below. For additional information, contact the manufacturer or your local distributor directly.

Conventional Columns versus High Performance Columns

Conventional Columns versus High Performance Column List

Conventional Columns (old)		High Performance Columns (new)	
5C ₁₈ -AR	→	5C ₁₈ -AR-II	
5C ₁₈	→	5C ₁₈ -MS-II	
5C ₁₈ -MS	→	5C ₁₈ -MS-II	
5C ₁₈ -P	→	5C ₁₈ -PAQ	
5C ₁₈ -P-MS	→	5C ₁₈ -PAQ	
5C ₈	→	5C ₈ -MS	
5TMS	→	5TMS-MS	
5PE	→	5PE-MS	
5CN-R	→	5CN-MS	
5NH ₂	→	5NH ₂ -MS	
5C ₁₈ -300	→	5C ₁₈ -AR-300	For information on performance comparison of COSMOSIL 5C ₁₈ -MS-II (new), 5C ₁₈ -MS (old) and 5C ₁₈ (old), please refer to page 213.
5C ₈ -300	→	5C ₈ -AR-300	
5C ₄ -300	→	5C ₄ -AR-300	For COSMOSIL 5C ₁₈ -AR-II (new) and 5C ₁₈ -AR (old), please refer to page 214.
5SL	→	5SL-II	

Ordering Information

Conventional Columns List

Product Name	Column Size I.D. x Length (mm)	Product Number
COSMOSIL 5C ₁₈ Packed Column	4.6 x 150	39047-81
	4.6 x 250	39265-21
COSMOSIL 5C ₁₈ -MS Packed Column	4.6 x 150	37971-21
	4.6 x 250	37972-11
COSMOSIL 5C ₁₈ -AR Packed Column	4.6 x 150	37861-61
	4.6 x 250	37862-51
COSMOSIL 5C ₁₈ -P Packed Column	4.6 x 150	39103-31
	4.6 x 250	39280-11
COSMOSIL 5C ₁₈ -P-MS Packed Column	4.6 x 150	37995-21
	4.6 x 250	37994-31
COSMOSIL 5C ₈ Packed Column	4.6 x 150	39042-31
	4.6 x 250	39260-71
COSMOSIL 5TMS Packed Column	4.6 x 150	39057-51
	4.6 x 250	39275-91
COSMOSIL 5CN-R Packed Column	4.6 x 150	39114-91
	4.6 x 250	39285-61
COSMOSIL 5NH ₂ Packed Column	4.6 x 150	39150-11
	4.6 x 250	39290-81
COSMOSIL 5C ₁₈ -300 Packed Column	4.6 x 150	39607-41
COSMOSIL 5SL Packed Column	4.6 x 150	39037-11
	4.6 x 250	39255-51

Other conventional columns may available, please inquire.



UHPLC Columns

COSMOSIL 2.5C₁₈-MS-II, 2.5Cholester, 2.5πNAP 62

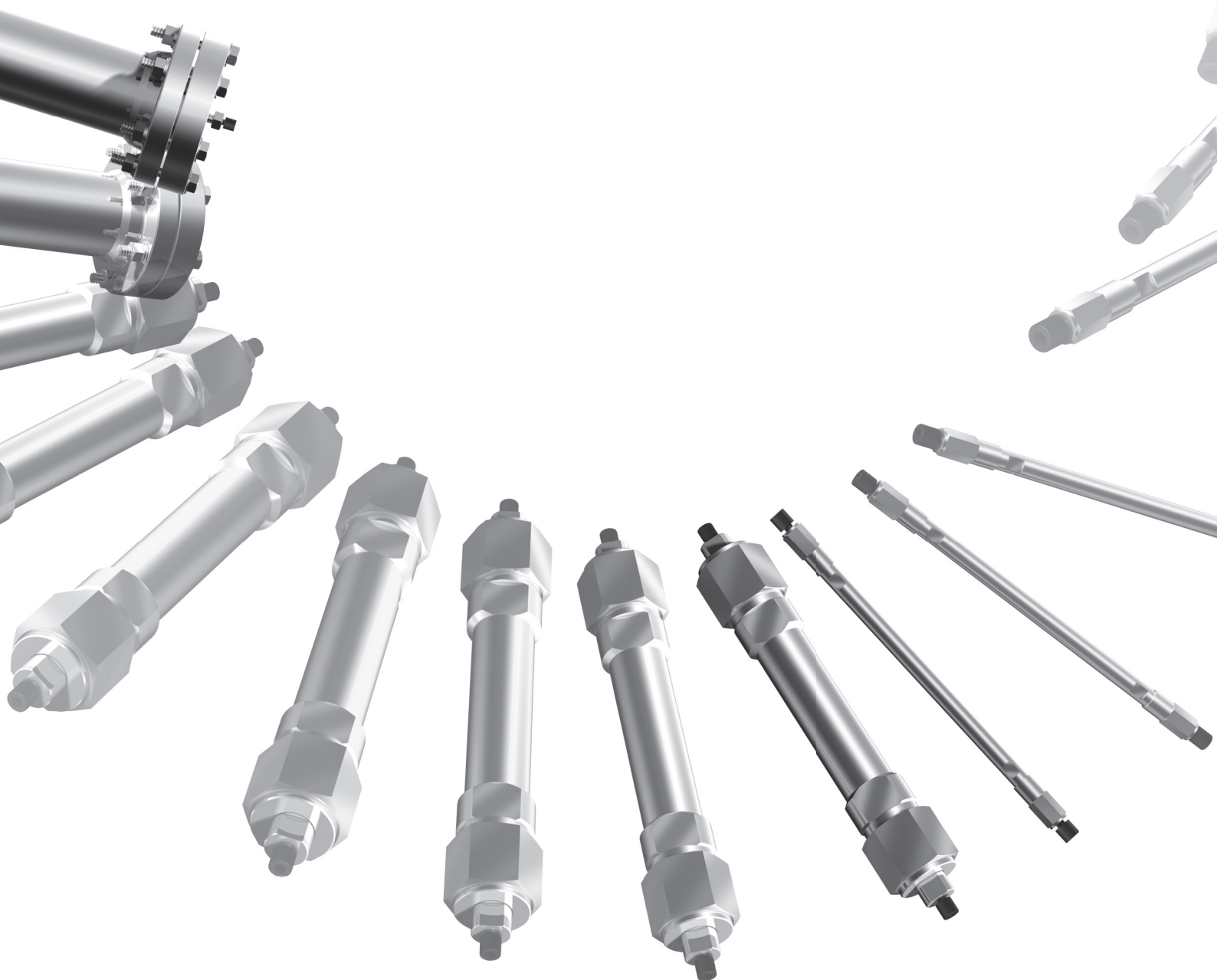

COSMOSIL 2.5C₁₈-MS-II, 2.5Cholester, 2.5πNAP

- Low back pressure (2.5 μm silica gel)
- 3 types of stationary phases (monomeric C₁₈, cholesterol group and naphthalene group)

Specifications

Packing Material	C ₁₈ -MS-II	Cholester	πNAP
Silica Gel	High Purity Porous Spherical Silica		
Average Particle Size	2.5 μm		
Average Pore Size	approx. 130 Å		
Specific Surface Area	approx. 330 m ² /g		
Bonded Phase	Octadecyl Group	Cholesteryl Group	Naphtylethyl Group
Bonding Type	Monomeric Type		
Main Interaction	Hydrophobic Interaction	Hydrophobic Interaction Molecular Shape Selectivity	Hydrophobic Interaction π-π Interaction
End-capping Treatment	Near-perfect Treatment		
Carbon Load	approx. 18%	approx. 21%	approx. 14%
Feature	• First choice of reversed phase column	• The same mobile phase as C ₁₈ • High molecular shape selectivity	• Stronger π-π interactions than phenyl columns

Ultra High Performance Liquid Chromatography (UHPLC)

Very fast and efficient separation can be achieved using 2.5 μm particles.

Note: Ultra high performance liquid chromatography system or some modification of HPLC system is required for UHPLC analysis. The following application is acquired by HPLC equipment for semi-micro column, and response of detector is 0.02 sec.

To Ultra Fast Liquid Chromatography

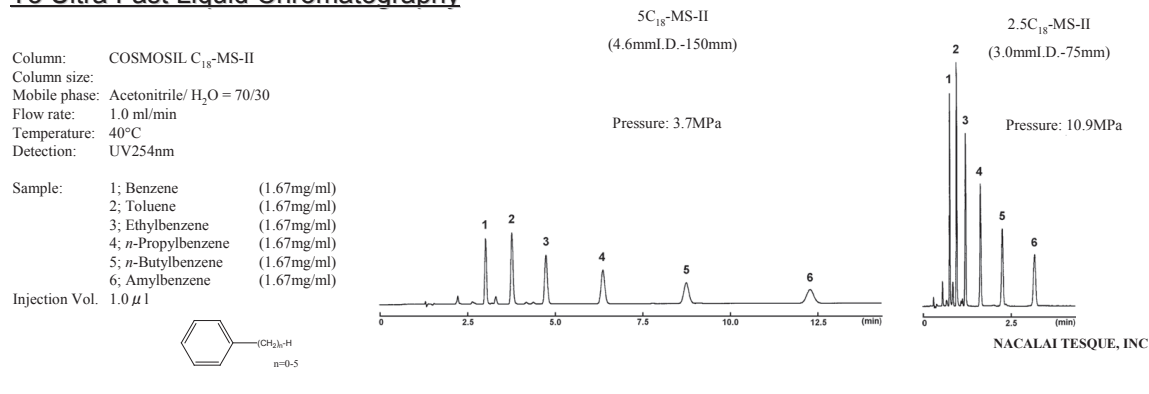

Comparison of Analytical Pressure

COSMOSIL 2.5 series can be used under lower pressure than competitors' 2 μm columns.

Comparison of Analytical Pressure

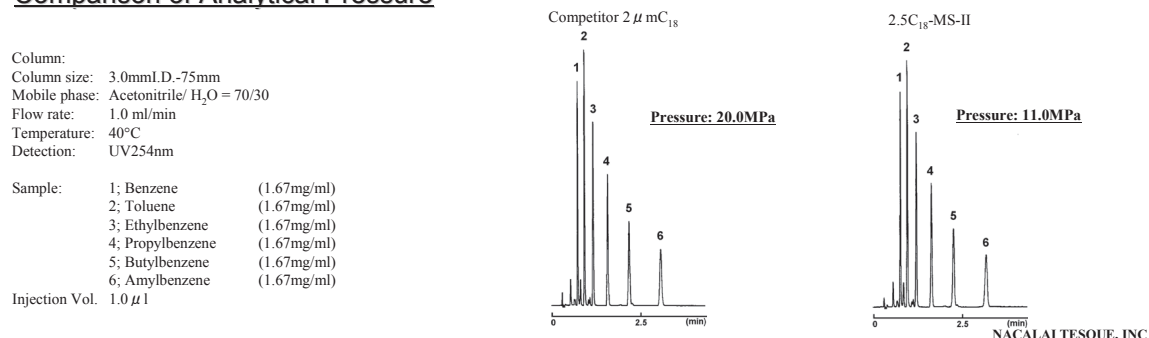

Applications

COSMOSIL 2.5Cholester offers improved resolution for compounds difficult to analyze with C₁₈ without changing analytical conditions. For more information on Cholester, refer to page 21.

• Saikosaponins

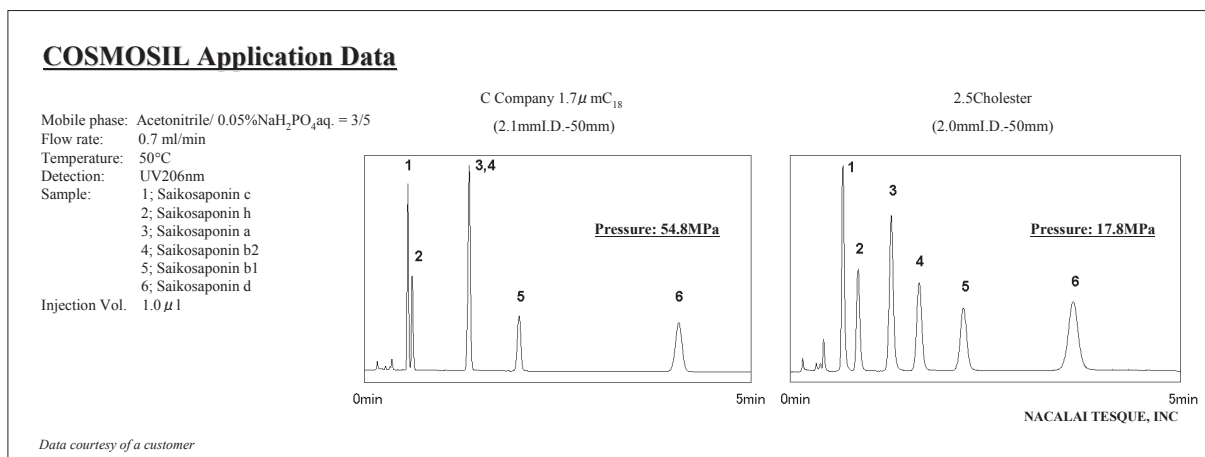

COSMOSIL 2.5πNAP provides greater performance in separating positional isomers and other closely related compounds which are difficult to analyze with C₁₈. For more information on πNAP, refer to page 24.

• Tocopherols

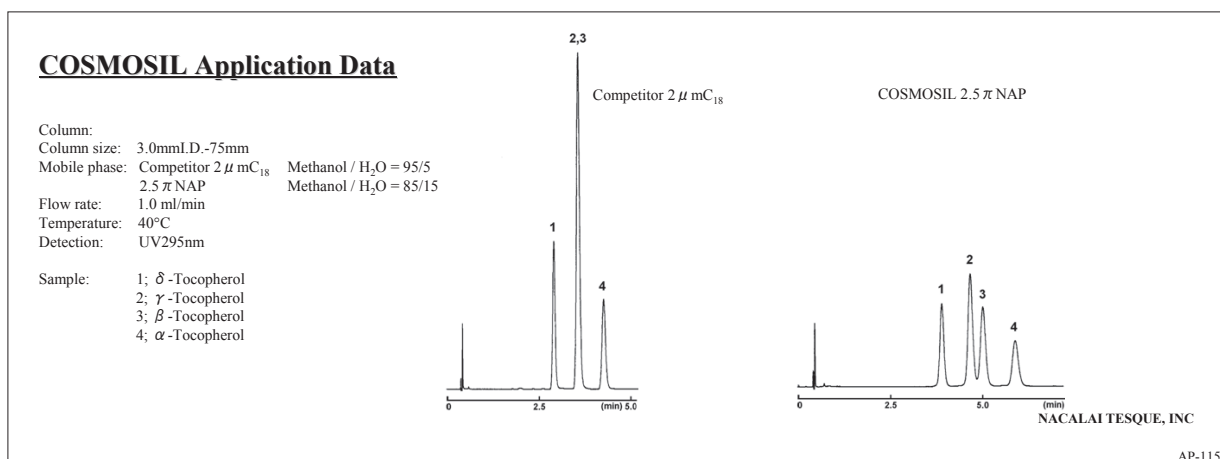

Ordering Information

• Analytical Column (Particle Size: 2.5 μm)

COSMOSIL 2.5C₁₈-MS-II Packed Column

Column Size I.D. x Length (mm)	Product Number
2.0 x 50	08994-31
2.0 x 75	08995-21
2.0 x 100	08996-11
3.0 x 50	08997-01
3.0 x 75	08998-91
3.0 x 100	08999-81

COSMOSIL 2.5Cholester Packed Column

Column Size I.D. x Length (mm)	Product Number
2.0 x 50	09000-01
2.0 x 75	09047-11
2.0 x 100	09048-01
3.0 x 50	09049-91
3.0 x 75	09050-51
3.0 x 100	09051-41

COSMOSIL 2.5πNAP Packed Column

Column Size I.D. x Length (mm)	Product Number
2.0 x 50	06062-91
2.0 x 75	06051-31
2.0 x 100	06052-21
3.0 x 50	06054-01
3.0 x 75	06055-91
3.0 x 100	06057-71



Preparative Packing Materials



1. Normal and Reversed Phase Packing Materials	66
COSMOSIL C ₁₈ -OPN	67
COSMOSIL C ₁₈ -PREP	70
COSMOSIL SL-II-PREP	71
Silica Gel (spherical, neutral)	72
Silica Gel (for column chromatograph)	73

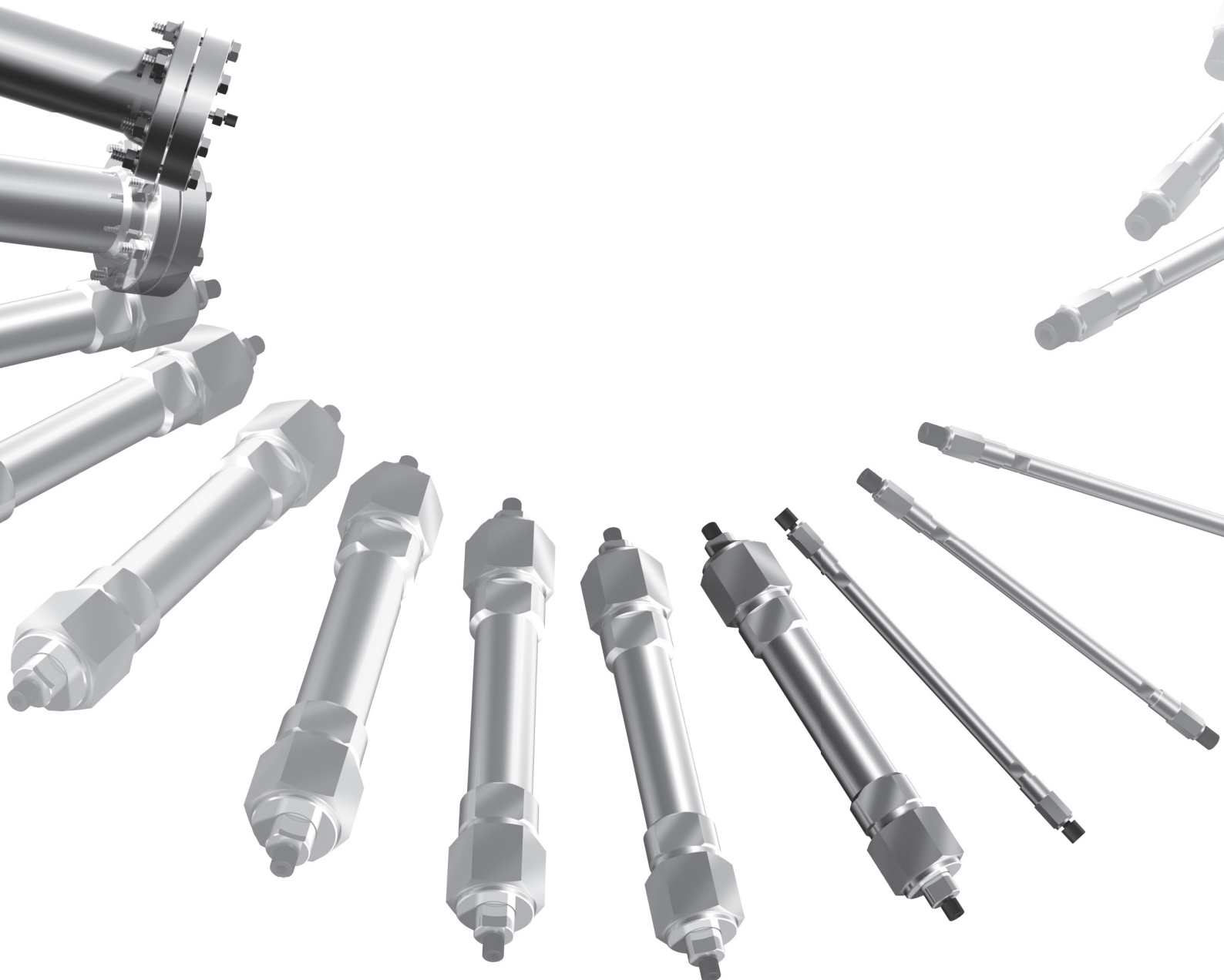

1. Normal and Reversed Phase Packing Materials

Introduction

Open column chromatography is an excellent and easy technique for large-scale preparation and purification at low cost. COSMO-SIL offers both normal and reversed phase packing materials based on totally porous spherical silica, which provides higher separation, less pressure and higher reproducibility than irregular silica.

Specifications

Packing Material	C ₁₈ -OPN	C ₁₈ -PREP	SL-II-PREP	Silica Gel 60 (neutral)
Silica Gel	High Purity Porous Spherical Silica			
Average Particle Size	75, 140 µm	40, 75, 140 µm	75, 140 µm	
Average Pore Size	approx. 120 Å			approx. 60 Å
Specific Surface Area	approx. 300 m ² /g			approx. 500 m ² /g
Bonded Phase	Octadecyl Group		None	
Carbon Load	—	approx. 19%	0%	
Residual Silanol Group	Yes	None	—	
Application	Open Column Chromatography / Flash Column Chromatography			
	Reversed Phase Chromatography		Normal Phase Chromatography	

For more informations on other silica gel, please refer to page 73.

Selection Guide (reversed phase)

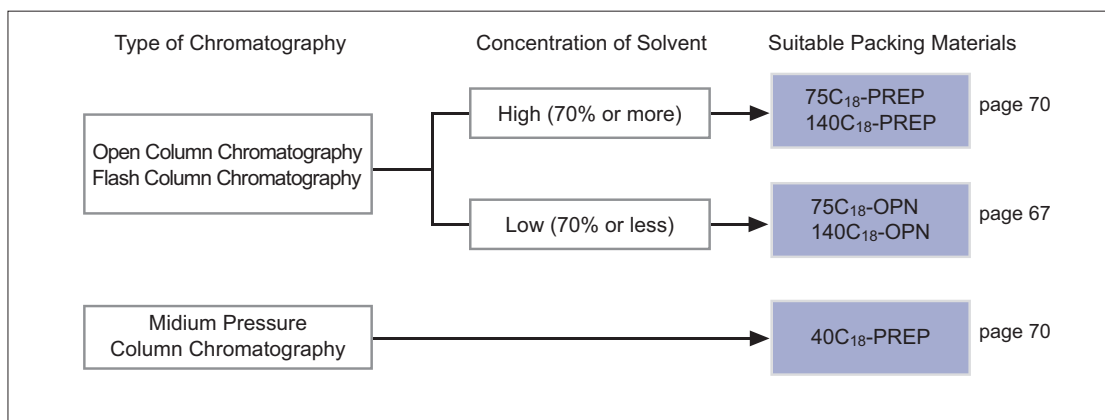

Selection Guide (normal phase)

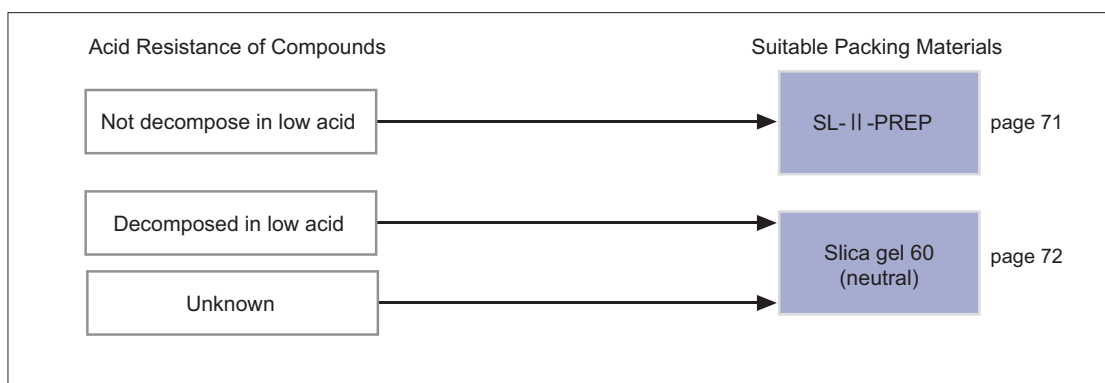

COSMOSIL C₁₈-OPN

- A new “Water-Wet” C₁₈ packing material for reversed phase open column chromatography
- Usable under 100% aqueous eluents

Characteristic

The external surface of the C₁₈-OPN gel is coated with hydrophilic group to increase wettability of the gel, and octadecyl group is bonded in the pore of the gel. Conventional reversed phase C₁₈ packing materials are restricted to about 30–50% water in the mobile phase. The COSMOSIL C₁₈-OPN is a new “Water-Wet” C₁₈ packing material developed for reversed phase open column chromatography. The C₁₈-OPN material can be used in 100% aqueous eluents.

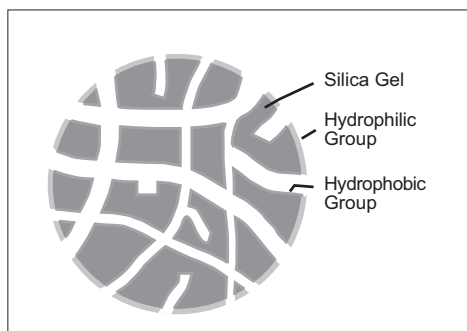

Figure 1. Structure of C₁₈-OPN

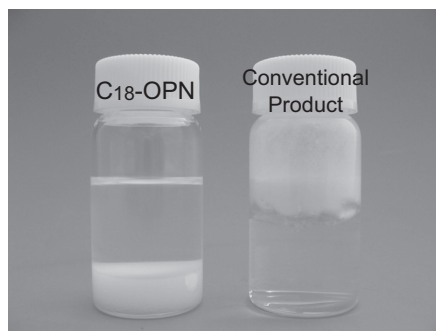
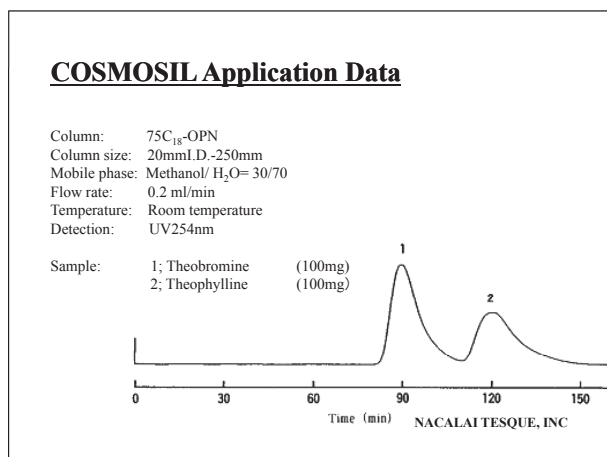

Figure 2. Packing material in water

- Left: C₁₈-OPN provides good resolution
Can be used with low concentration of organic solvent on open, flash column chromatography.
- Right: C₁₈-PREP float up
Use with 70% or more organic solvent on open, flash column chromatography.

Applications

- Separation of hydrophilic compounds in aqueous solution



In reversed phase chromatography, hydrophilic compounds such as Theobromine and Theophylline could be separated under low concentration of organic solvent. The figure shows they are clearly separated by reversed open column chromatography with 70% of water.

Influence of Particle Size

The table below shows comparison between 75 μm and 140 μm particle size silica. Although peak shapes and flow rate may differ based on particle size of silica, elution behavior is the same.

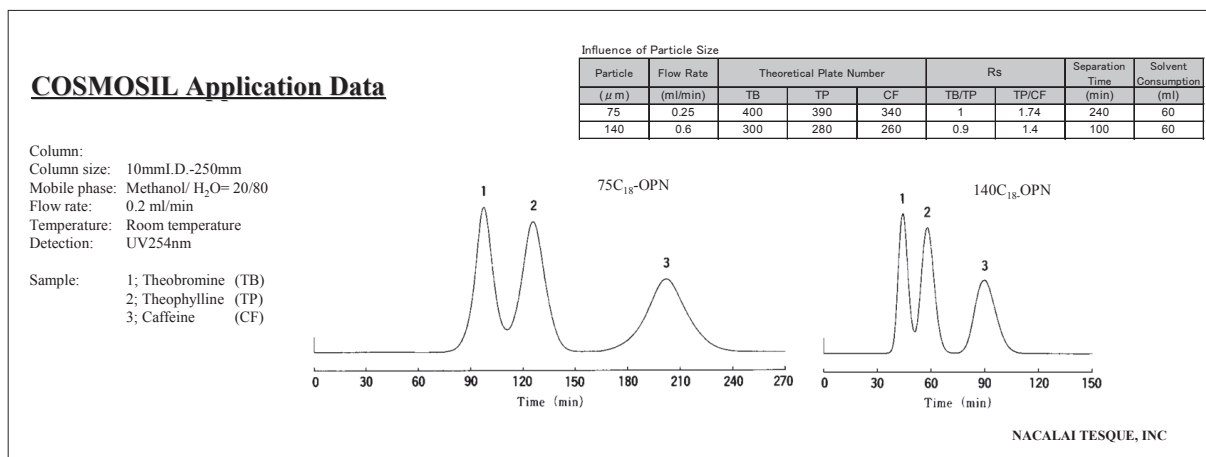

Flow Rate

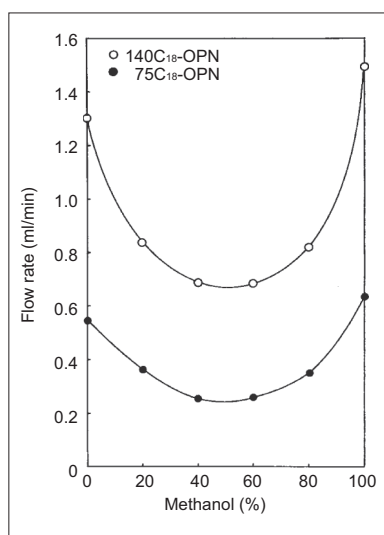

Since reversed phase chromatography generally employs high viscosity solvents such as water and methanol, the flow rate is lower than that of normal phase chromatography. The flow rate of reversed phase depends on the mobile phase composition. The figure left indicates that the flow rate of the COSMOSIL 140C₁₈-OPN (140 μm in particle size) is about 2.5 times higher than that of the COSMOSIL 75C₁₈-OPN.

Figure. Concentration of methanol against flow rate

Column size: 10 mm I.D. x 180 mm bed height (gravitational liquid flow)

Comparison of Normal Phase

- Separation of *p*-Cresol and *p*-Ethylphenol by normal and reversed phase mode

Since the structural difference between *p*-Cresol and *p*-Ethylphenol is only one methylene group, it is difficult to separate such samples under normal phase condition. On the other hand, the samples are clearly separated under reversed phase condition with COSMOSIL C₁₈-OPN packing material.

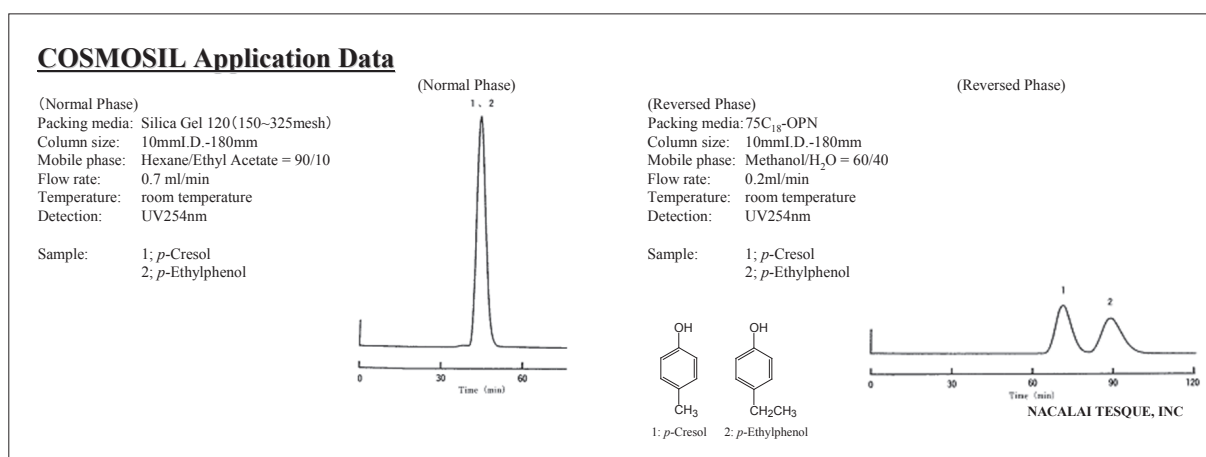

Column Packing Instructions

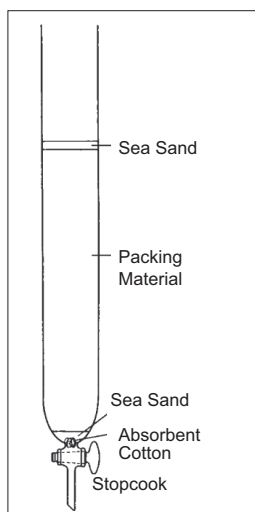

1. Use a standard open glass column, close the stopcock, pack a small amount of absorbent cotton in the bottom of the column and add solvent to approximately 1/3 of the column length.
2. Add a thin layer (5 mm) of sea sand to the surface of the absorbent cotton.
3. Prepare a slurry solution of the packing material (30% w/v) with solvent right before packing. (Make sure to prepare enough slurry solution to form a column bed sufficient to separate the compounds of interest.)
4. Simultaneously open the stopcock and add the slurry solution to the column to form the column bed.
5. After packing the column, wash the newly packed column bed with 5–10 column volumes of solvent. Allow the bed to stabilize overnight in solvent.
6. Add a thin layer (5 mm) of sea sand to the top of the bed in order to prevent disturbance of the top of the column bed during sample or solvent addition.

Column Size and Required Amount of Packing Material

Table. Column size and required amount of C₁₈-OPN packing material

Column I.D. (mm)	Bed Height (mm)	Amount of C ₁₈ -OPN (g)
10	150	4
	250	7
20	150	17
	250	28
30	150	38
	250	63

Reproducibility and Washing Methods

Wash the COSMOSIL C₁₈-OPN packing material with tetrahydrofuran, chloroform or other solvents to remove the impurities. This packing material has excellent reproducibility and can be used repeatedly.

“Attention”

1. Do not wash with basic solvents of pH 7 or more which will dissolve the silica gel or pH 2 or less which will cleave the C₁₈ stationary phase.
2. Dry the packing material at 50°C or less.

Ordering Information

● COSMOSIL C₁₈-OPN

Product Name	Average Particle Size	Product Number	PKG Size
COSMOSIL 75C ₁₈ -OPN	75µm	37842-66	100 g
		37842-95	500 g
		37842-11	1 kg
COSMOSIL 140C ₁₈ -OPN	140µm	37878-16	100 g
		37878-45	500 g
		37878-61	1 kg

COSMOSIL C₁₈-PREP

- Standard reversed phase packing material for open chromatography
- End-capping treated
- 3 types of particle size (40, 75, 140 μm)

Particle Size, Flow Rate and Theoretical Plate Number

Because reversed phase chromatography employs mobile phase of high viscosity such as methanol and water, the flow rate is lower than that of normal phase chromatography, which uses mobile phase of low viscosity such as hexane and ethyl acetate.

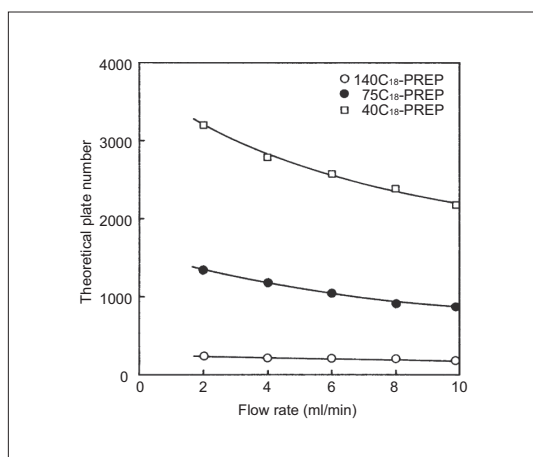

Figure 1. Flow rate against theoretical plate number
Column size: 20 mm I.D. x 300 mm

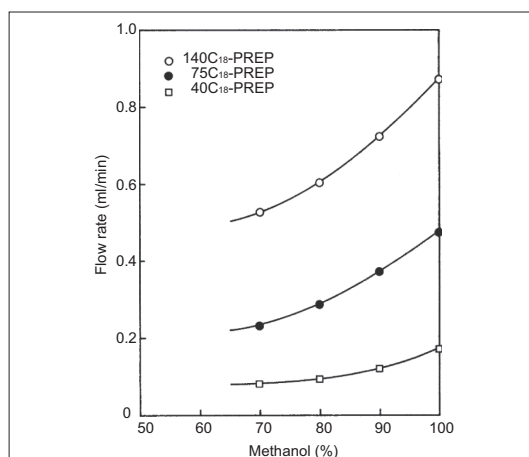
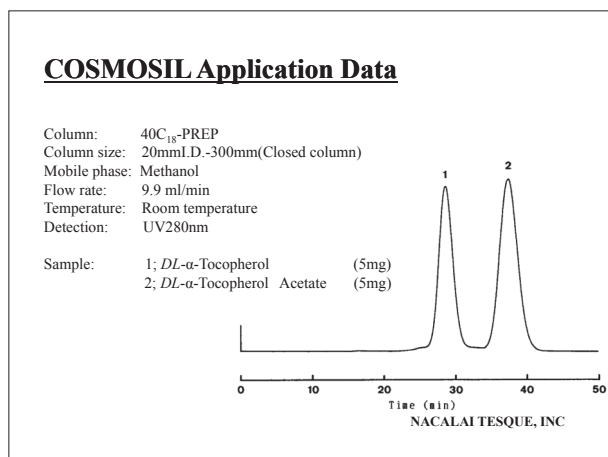

Figure 2. Concentration of methanol against flow rate
Column size: 10 mm I.D. x 180 mm bed height
(gravitational liquid flow)

Applications

• Vitamin E



• Natural Compounds

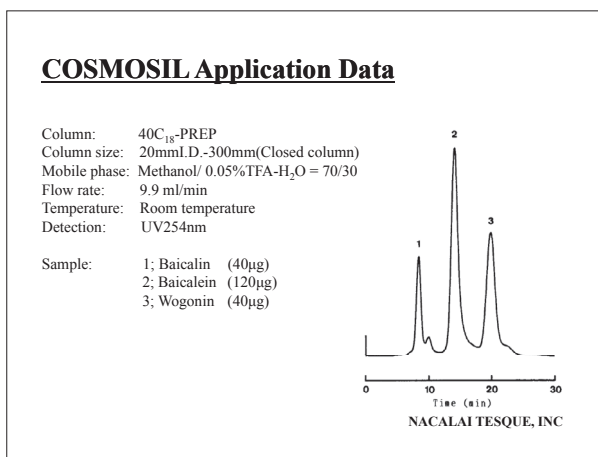

Ordering Information

• COSMOSIL C₁₈-PREP

Product Name	Average Particle Size	Product Number	PKG Size
COSMOSIL 40C ₁₈ -PREP	40 μm	37932-86	100 g
		37932-15	500 g
		37932-31	1 kg
COSMOSIL 75C ₁₈ -PREP	75 μm	37933-76	100 g
		37933-05	500 g
		37933-21	1 kg
COSMOSIL 140C ₁₈ -PREP	140 μm	37934-66	100 g
		37934-95	500 g
		37934-11	1 kg

COSMOSIL SL-II-PREP

- Standard packing materials for normal phase chromatography
- Ultra pure silica gel packing material more than 99.99% purity

Performance for Chelating Compounds

Highly purified silica gel of COSMOSIL SL-II-PREP enables separation of metal coordination compounds without adsorption.

• Metal Coordination Compounds

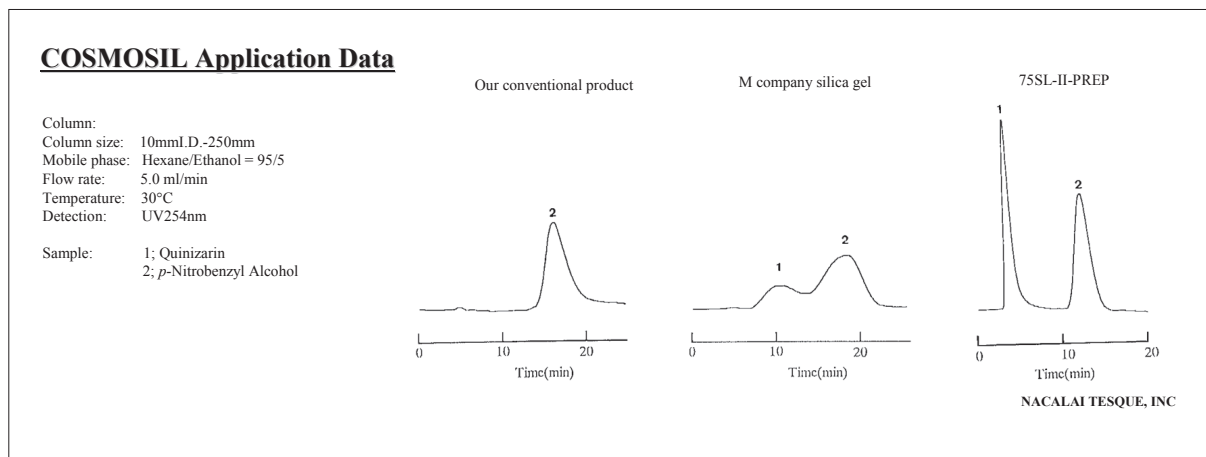

• Organic Acid and Amide

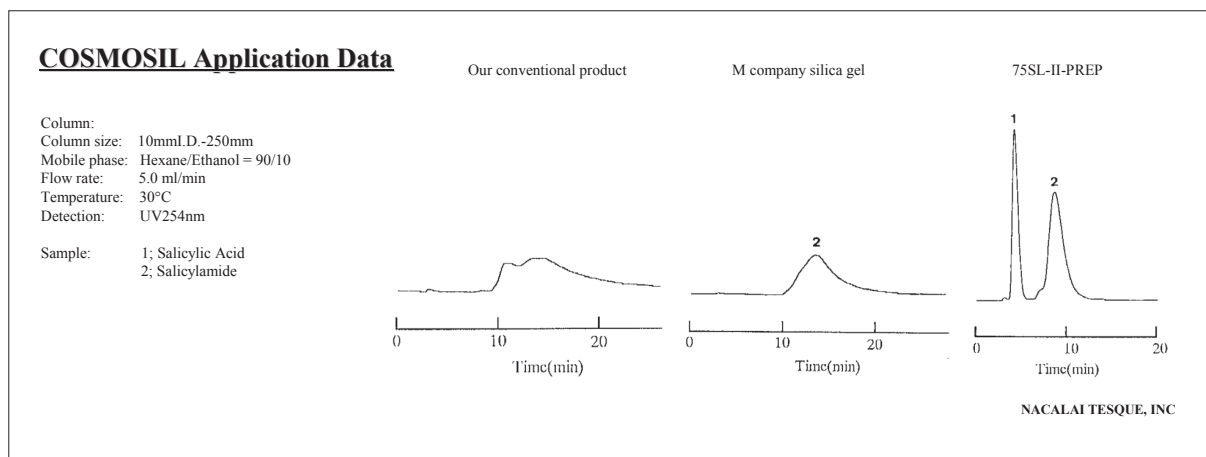

Ordering Information

• COSMOSIL SL-II-PREP

Product Name	Average Particle Size	Product Number	PKG Size
COSMOSIL 75SL-II-PREP	75 μm	38012-64	100 g
		38012-35	500 g
		38012-51	1 kg
COSMOSIL 140SL-II-PREP	140 μm	38013-54	100 g
		38013-41	1 kg

Silica Gel (spherical, neutral)

- The pH of Silica Gel is adjusted to neutral
- Suitable for the separation of pH sensitive compounds

Comparison with Conventional Silica Gel

- Purification of Acetal -1

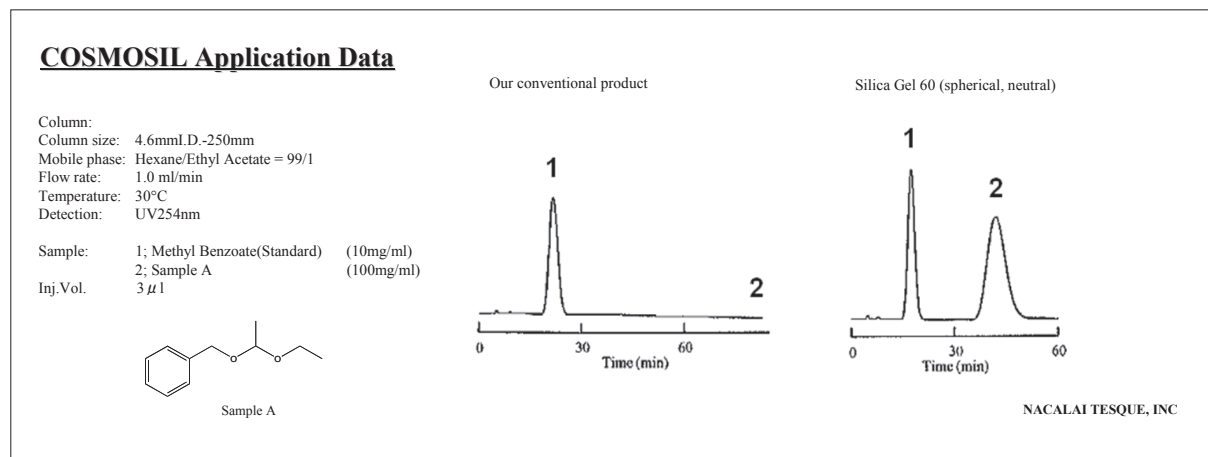

- Purification of Acetal -2

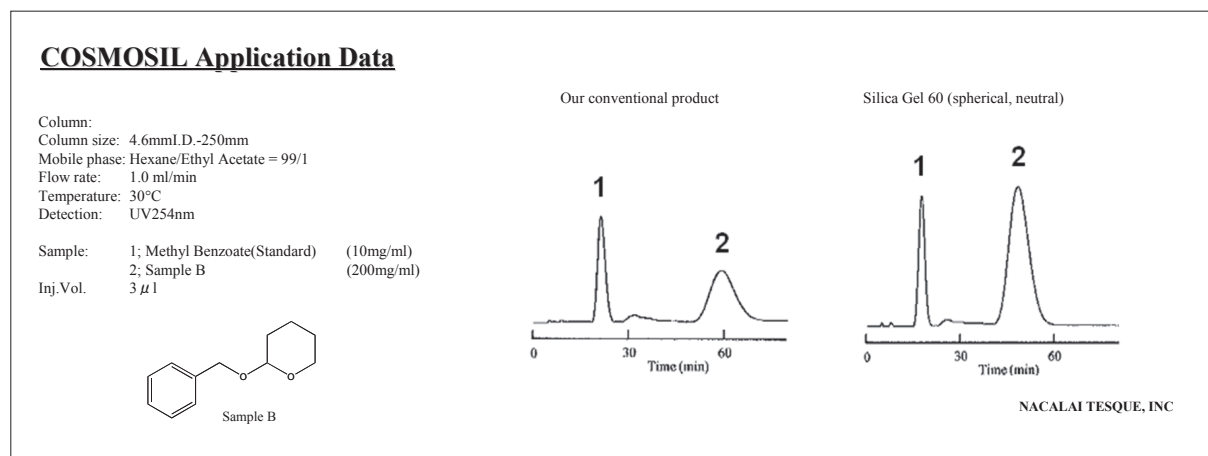

Ordering Information

- Silica gel 60 (spherical, neutral)

Product Name	Average Particle Size	Product Number	PKG Size
Silica Gel 60 (spherical, neutral) for Column Chromatograph	75 µm	30511-64	100 g
		30511-35	500 g
		30511-51	1 kg
		30511-06	5 kg
		30511-22	25 kg
	140 µm	30518-94	100 g
		30518-65	500 g
		30518-81	1 kg
		30518-52	25 kg

Silica Gel (for column chromatograph)

Ordering Information

• Silica Gel (spherical)

Product Name	Particle Size	Pore Size	Grade	Product Number	PKG Size
Silica Gel 60, Spherical	approx. 70 ~ 230 mesh	60 Å	SP	30731-71	1 kg
				30731-42	25 kg
	approx. 150 ~ 325 mesh		SP	30733-51	1 kg
				30733-22	25 kg
Silica Gel 120, Spherical	approx. 70 ~ 230 mesh	120 Å	SP	30734-41	1 kg

• Silica Gel (irregular)

Product Name	Particle Size	Pore Size	Grade	Product Number	PKG Size
Silica Gel 60	approx. 70 ~ 230 mesh	60 Å	SP	30724-55	500 g
				30724-71	1 kg
				30724-84	5 kg
				30724-42	25 kg
	approx. 230 ~ 400 mesh		SP	30721-85	500 g
				30721-01	1 kg
			30721-14	5 kg	

IV

Related Products

1. Reagents for Mobile Phase Preparation.....	76
Solvents, Additives	76
Phosphate Buffer Solution (pH 2.5) (5x).....	77
Ion-pair Reagents	78
2. Prefiltration Tool for Liquid Chromatography	80
Cosmonice Filter.....	80
Cosmospin Filter.....	80
Labeling Reagents.....	82
3. Column Care Products	85
Cleaning Solution Kit for Reversed Phase HPLC Columns.....	85
Storage Solution for Reversed Phase HPLC Columns.....	86
4. COSMOSIL HPLC Accessories.....	87

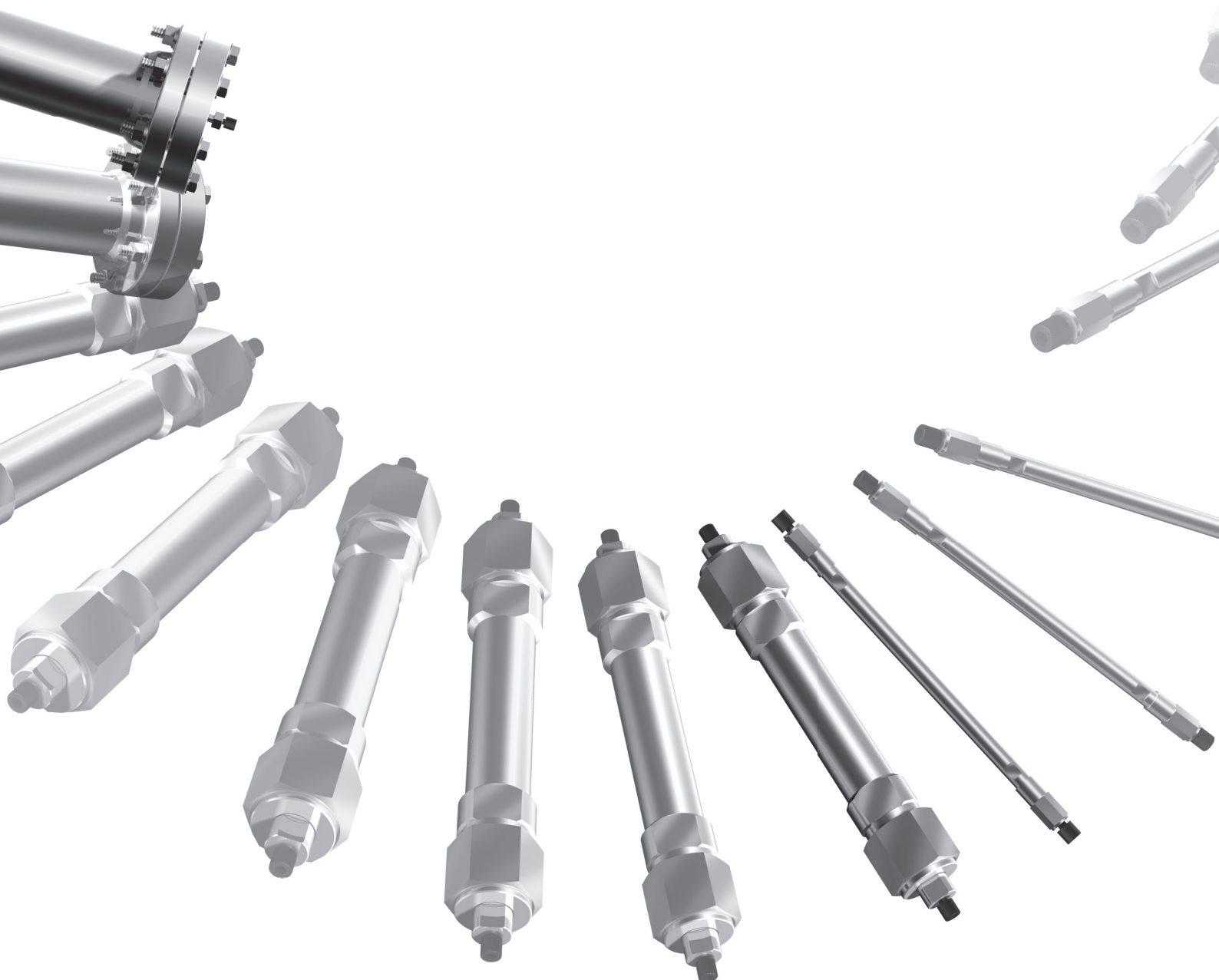

1. Reagents for Mobile Phase Preparation

Solvents, Additives

Specification

HPLC grade solvents and additives are specifically designed for HPLC applications with the specifications including; purity, specific gravity, refraction index, absorbance, water, non-volatile matter, peroxide and fluorescence.

* Specifications vary by solvent.

Ordering Information

• Solvents

Product Name	Grade	Product Number	Package Size
Acetone	SP	00325-31	1 L
Acetonitrile	SP	00430-25	500 ml
		00430-41	1 L
		00430-83	3 L
Benzene	SP	04028-11	1 L
1-Butanol	SP	06024-91	1 L
<i>t</i> -Butyl Methyl Ether	SP	06332-64	200 ml
		06332-51	1 L
Chloroform	SP	08426-71	1 L
		08426-13	3 L
Cyclohexane	SP	10034-31	1 L
<i>o</i> -Dichlorobenzene	SP	11635-31	1 L
1,2-Dichloroethane	SP	15223-01	1 L
Dichloromethane	SP	22423-61	1 L
<i>N,N</i> -Dimethylformamide	SP	13024-71	1 L
1,4-Dioxane	SP	13631-11	1 L
Distilled Water	SP	14029-91	1 L
		14029-33	3 L
Ethanol (99.5V%)	SP	14741-25	500 ml
		14741-41	1 L
		14741-83	3 L
Ethyl Acetate	SP	14746-91	1 L
		14746-33	3 L
Heptane	SP	17623-01	1 L
1,1,1,3,3,3-Hexafluoro-2-propanol	SP	17814-14	100 g
		17814-85	500 g
Hexane	SP	17929-11	1 L
		17929-53	3 L
Methanol	SP	21929-81	1 L
		21929-23	3 L
Phosphate Buffer Solution (pH 2.5) (5x)	SP	08969-71	1 L
Phosphate Buffer Solution (pH 7.0) (5x)	SP	08968-81	1 L
1-Propanol	SP	29033-61	1 L
2-Propanol	SP	29128-31	1 L
		29128-73	3 L
Tetrahydrofuran	SP	33125-31	1 L
		33125-73	3 L
Toluene	SP	34130-21	1 L
		34130-63	3 L

• Additives

Product name	Grade	Product Number	Package Size
Acetic Acid	SP	08963-02	25 ml
Formic Acid	SP	08965-82	25 ml
Phosphoric Acid, Ortho	SP	08964-92	25 ml
Trifluoroacetic Acid	SP	34840-21	5×1 ml
		34840-76	5×1.5 ml
		34840-63	5×3 ml
		34840-34	10 ml

Phosphate Buffer Solution (pH 2.5) (5x)

- pH adjusted
- Filtered (0.2 µm)
- UV, Fluorescence tested
- Easy to prepare the mobile phase used in COSMOSIL Applications

How to Prepare

Dilute this product 1:4 with HPLC grade distilled water to make the 20 mmol/l phosphate buffer used in the following COSMOSIL Applications.

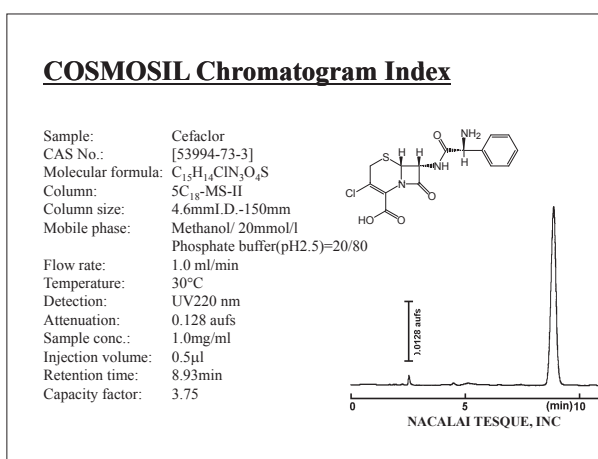
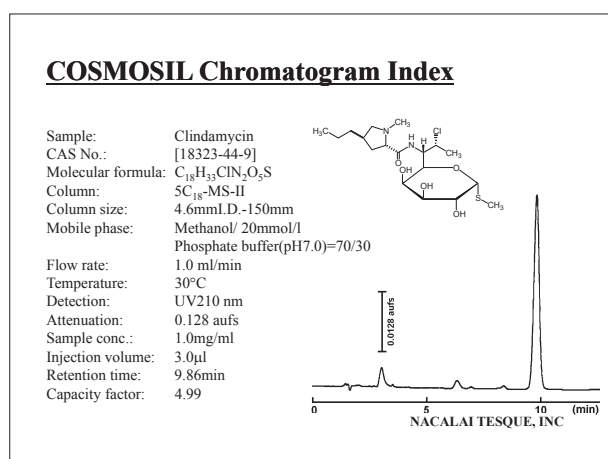

For more information on COSMOSIL Chromatogram Applications, please refer to page 90.

Attention

1. This product is designed to prepare the 20 mmol/l phosphate buffer. If the product is diluted to different concentrations, confirm pH before use.
2. Use distilled water (Product No. 14029).
3. Keep refrigerated and use promptly after opening.

Ordering Information

- Phosphate Buffer Solution (5x)

Product Name	Grade	Product Number	PKG Size
Phosphate Buffer Solution (pH 2.5) (5x)	SP	08969-71	1 L
Phosphate Buffer Solution (pH 7.0) (5x)	SP	08968-81	1 L

Ion-pair Reagents

Introduction

The use of ion pair reagents as mobile phase additives extends the applicability of reversed phase HPLC. Ionic or highly polar compounds are difficult to analyze by reversed phase using only organic solvent and buffer solution because of the short retention time. Ion pair reagents are strong hydrophobic ions which form neutral ion pairs with oppositely charged samples molecules, making the efficient ODS columns amenable to separate ionic or highly polar samples. Nacalai Tesque offers a broad range of ion pair reagents for pharmaceutical compounds and other highly polar materials.

General Use of Ion-pair Reagents

When using ion pair reagents, ample time should be allowed for establishing equilibrium and for cleaning the column.

When using ion pair reagents with an alkyl chain of C₁₀ or shorter, it typically takes 20 minutes for establishing equilibrium and 30 minutes for cleaning. It may take more than 1 hour to clean the column when using ion pair reagents with an alkyl chain longer than C₁₀. Therefore, it is highly recommended to prepare a column for exclusive use with ion pair reagents.

Condition Setting

Follow the condition setting below.

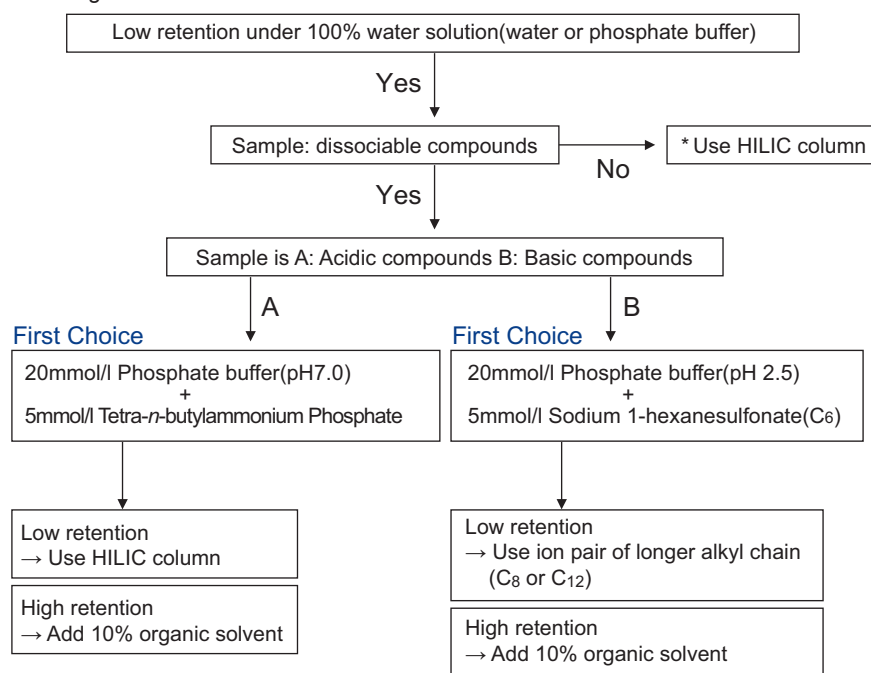

*For HILIC column, please refer to page 36.

Condition Setting

Column: 5C₁₈-PAQ
Column size: 4.6mm I.D.-150mm
Mobile phase:
Flow rate: 1.0 ml/min
Temperature: 30°C
Detection: UV270nm

Sample: 1; L-Noradrenaline
2; L-Adrenaline
3; L-DOPA
4; Dopamine

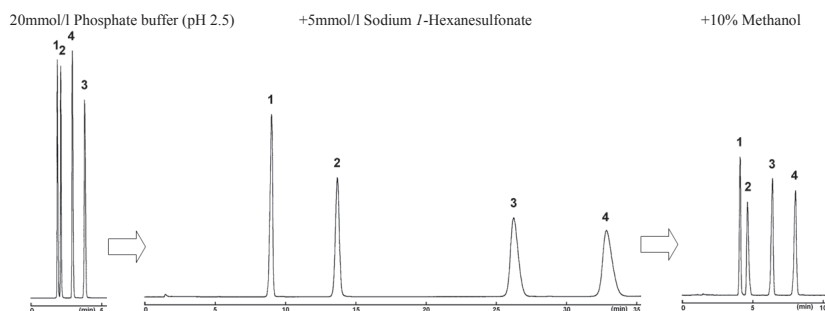

Applications

• Low-molecular-weight Unsaturated Carboxylic Acids

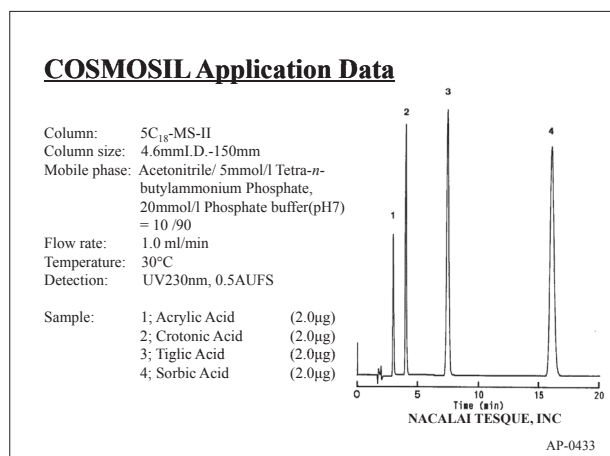

• Amino Acids

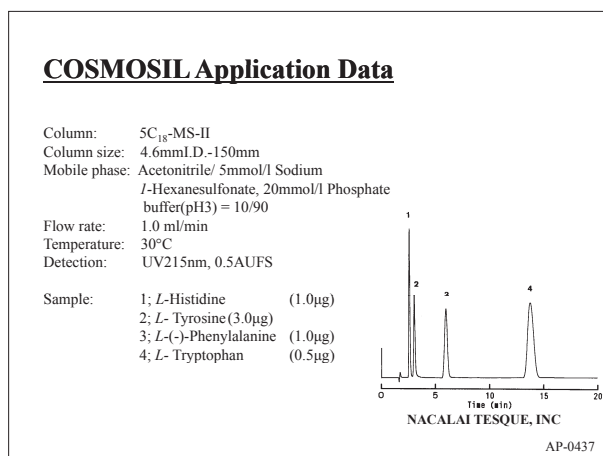

Ordering Information

• for Basic Samples

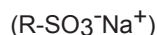

Product Name	R:	Grade	Product Number	PKG Size
Sodium 1-Butanesulfonate	C ₄ H ₉ -	SP	31331-94	5 g
Sodium 1-Pentanesulfonate	C ₅ H ₁₁ -	SP	31730-64	5 g
			31730-22	25 g
Sodium 1-Hexanesulfonate	C ₆ H ₁₃ -	SP	31529-24	5 g
			31529-82	25 g
Sodium 1-Heptanesulfonate	C ₇ H ₁₅ -	SP	31528-34	5 g
			31528-92	25 g
Sodium 1-Octanesulfonate	C ₈ H ₁₇ -	SP	31729-04	5 g
			31729-62	25 g
Sodium 1-Nonanesulfonate	C ₉ H ₁₉ -	SP	31626-44	5 g
Sodium 1-Decanesulfonate	C ₁₀ H ₂₁ -	SP	31429-34	5 g
Sodium 1-Dodecanesulfonate	C ₁₂ H ₂₅ -	SP	31426-64	5 g
Sodium Lauryl Sulfate	**	SP	31623-32	25 g

0.5M Solution

Sodium 1-Butanesulfonate	C ₄ H ₉ -	SP	31332-84	5×10 ml
Sodium 1-Hexanesulfonate	C ₆ H ₁₃ -	SP	31532-64	10 ml
			31532-06	5×10 ml
Sodium 1-Octanesulfonate	C ₈ H ₁₇ -	SP	31733-34	10 ml
			31733-76	5×10 ml

• for Acid Samples

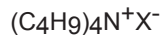

Product Name	X ⁻ :	Grade	Product Number	PKG Size
Tetra- <i>n</i> -butylammonium Bromide	-Br	SP	32824-72	25 g
Tetra- <i>n</i> -butylammonium Chloride	-Cl	EP	32935-51	1 g
			32935-64	5 g
			32935-22	25 g
Tetra- <i>n</i> -butylammonium Hydrogensulfate	-HSO ₄	GR	32924-62	25 g
Tetra- <i>n</i> -butylammonium Iodide	-I	SP	32905-54	5 g
			32905-12	25 g
Tetra- <i>n</i> -butylammonium Perchlorate	-ClO ₄	SP	32906-44	5 g
			32906-02	25 g
Tetra- <i>n</i> -butylammonium Phosphate	-H ₂ PO ₄	SP	32929-54	5 g

0.5M Solution

Tetra- <i>n</i> -butylammonium Phosphate	-H ₂ PO ₄	SP	32926-26	10 ml
			32926-84	5×10 ml

2. Prefiltration Tool for Liquid Chromatography

Cosmonice Filter

- For sample filtration
- Just attach a filter on top of a syringe

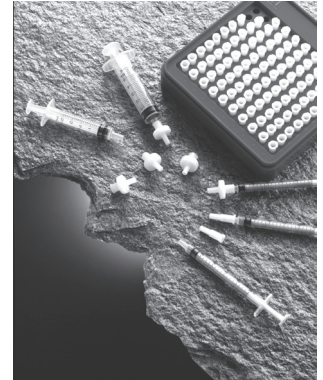

W Series (aqueous solution)

W series are installed new material of low-adsorptive and low-extractive durapore-filter (poly vinylidenedifluoride, PVDF) which can be used for the various solvents. So they are able to minimize the loss of the proteins in the small amount of sample, and to prevent from secondary contamination at the prefiltration.

S Series (organic solvents)

S series are installed teflon-filter (poly tetrafluoroethylene, PTFE) shows strong resistance for solvents, acids, and alkalis. It is the best for the prefiltration of the sample extracted with solvents such as chloroform, tetrahydrofuran, and so on.

Please refer to Technical Information 4, Sample pretreatment for HPLC at page 193.

Ordering Information

- Cosmonice Filter

Product Name	Diameter (mm)	Pore Size (µm)	Process Volume	Hold-up Volume	Product Number	PKG Size
Cosmonice Filter W (aqueous)	4	0.45	1 ml or less	< 10 µl	06543-04	100 pkg
	13	0.45	0.5~10 ml	< 30 µl	06544-94	100 pkg
Cosmonice Filter S (solvent)	4	0.45	1ml or less	< 10 µl	06541-24	100 pkg
	13	0.45	0.5~10 ml	< 30 µl	06542-14	100 pkg

[Connection] Inlet: luer-lock, Outlet: luer-slip, Connectable needles
*housing : polyethylene

Cosmospin Filter

- For Sample filtration
- Easy to use by centrifugation
- Omnipore hydrophilic PTFE membrane filter



Please refer to Technical Information 4, Sample pretreatment for HPLC at page 193.

Ordering Information

- Cosmospin Filter

Product Name	Pore Size (µm)	Maximum Sample Volume	Hold-up Volume	Maximum Centrifugal Force	Rotor Size (fixed-angle)	Filtration Area	Color	Product Number	PKG Size
Cosmospin Filter G	0.2	0.4 ml	5 µl	5000 xg	1.5 ml	0.2 cm ²	Brown	06549-44	100 pkg
Cosmospin Filter H	0.45	0.4 ml	5 µl	5000 xg	1.5 ml	0.2 cm ²	White	06540-34	100 pkg

Dimension: Diameter 10.6 mm x Length 45 mm Membrane: Omnipore Hydrophilic PTFE Sample reservoir and collection tube: Polypropylene

Chemical Compatibility

Solvent	Cosmonice W series	Cosmonice S series	Cosmospin	Solvent	Cosmonice W series	Cosmonice S series	Cosmospin
Acetic acid, 98%	+	+	+	Hydrogen gas	+	+	+
Acetone	-	+	+	Hydrogen peroxide (3%)	+	+	
Acetonitrile	+	+	+	Hydraulic oil (5606)	+	+	+
Ammonia solution (6N)	+	+	+	Hypo (photo)	+	+	+
Ammonium hydroxide (conc.)	+	+	-	Isopropyl acetate	+	+	+
Amyl alcohol	+	+	+	Isopropyl alcohol	+	+	+
Benzene	+	+	-	Kerosene	+	+	+
Benzyl alcohol	+	+	-	Methanol	+	+	+
Boric acid	+		+	Methyl ethyl ketone	-	+	+
Butyl acetate		+		Methyl isobutyl ketone	+	+	-
Carbon tetrachloride	+	+	+	2-Methyl-1-propanol	+	+	+
Chloroform	+	+	+	Nitric acid (6N)	+	+	
Cyclohexanone	-	+	-	Nitrobenzene	+	+	-
Dichloromethane	+	+	-	Ozone gas	-	+	-
Dimethylacetamide	-	+	+	Paraldehyde		+	
Dimethylformamide	+	+	+	Pentane	+	+	-
Dimethylsulfoxide	-	+	-	Petroleum ether	+	+	
Dioxane	+	+	+	Phenol (water saturation)	+	+	-
DMSO	-	+	-	Phosphate buffer solution	+		+
Ethers	+	+	+	2-Propanol	+	+	+
Ethyl acetate	+	+	+	Pyridine	-	+	+
Ethyl alcohol	+	+	+	Seawater	+	+	+
Ethyl cello solve	+	+	+	Silicone oils	+	+	+
Ethylene glycol	+	+	+	Sodium hydroxide (conc.)	+	+	+
Formamide	+	+	+	Sulfuric acid (6N)		+	
Freon, TF or PCA solvent	+	+	+	Toluene	+	+	-
Gasoline	+	+	+	THF	-	+	-
Glycerine (Glycerol)	+	+	+	Trichloroacetic acid	+	+	+
Helium gas		+	+	Trichloroethane	+	+	-
Hexane	+	+	-	Trichloroethylene	+	+	-
Hydrochloride (6N)	+	+	+	TFA	+	+	-
Hydrofluoric acid	-	+	-	Xylene	+	+	+

+ : Recommended, - : Not recommended, (blank) : Not data available

I. HPLC Columns

II. UHPLC Columns

III. Preparative Packing Materials

IV. Related Products

V. Applications

VI. Technical Notes

VII. Index

Labeling Reagents

Introduction

Labeling reagents enable high sensitivity detection and improved separation of amino acids or lipids. These reagents are available with various types.

• Dabsyl Chloride (4-Dimethylaminoazobenzene-4'-sulfonyl Chloride) (Visible labeling reagent)

Dabsyl Chloride is a dark-red crystalline, amino group labeling reagent with melting point of 185–188°C. It is insoluble in water and slightly soluble in acetone. Dabsyl derivatives with strong absorption in the visible part (maximum absorption of 430 nm) are formed when the chemical bonding occurs between Dabsyl Chloride and amines, or amino acids. It shows 100-fold increased sensitivity comparing to DNBC (3,5-Dinitrobenzoyl Chloride), and the same sensitivity as with fluorescence labeling reagent, Dansyl Chloride.

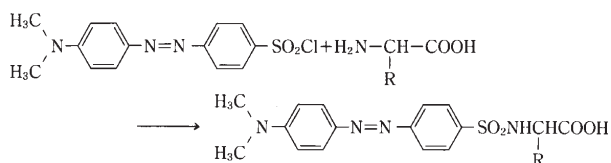

COSMOSIL Application Data

Column: 5C₁₈-MS-II
Column size: 4.6mm I.D.-150mm
Mobile phase: Methanol/ 20mmol/l Phosphoric Acid = 70/30
Flow rate: 1.0 ml/min
Temperature: 30°C
Detection: UV430nm, 2.56AUFS

Sample: 1; Dabsyl-Glycine
2; Dabsyl-L-Alanine
3; Dabsyl-L-Valine
4; Dabsyl-L-Leucine

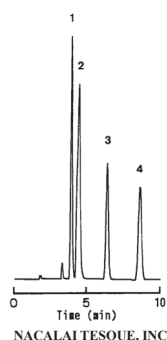

NACALAI TESQUE, INC
AP-0438

E.g.,) 1) Labeling of amino acids

Dissolve 60 nmol amino acid in 0.3 ml of sodium hydrogen carbonate buffer (pH 8.9, 0.1 mol/l). Add 0.3 ml of 10 μmol/l acetone solution of Dabsyl Chloride. Agitate the solution at 70°C for 6 minutes.

2) Labeling of Peptides

Dissolve 300 nmol sample in 0.3 ml of sodium hydrogen carbonate buffer (pH 8.9). Add 0.5 ml of 10 μmol/l acetone solution of Dabsyl Chloride. Agitate the solution at 70°C for 6 minutes. Vacuum dry the solution. Add 1.5 ml of 5.7 N-hydrochloric acid, and hydrolyze it at 105°C for 3 hours.

Ref. 1) J.K.Lin, J.Y.Chang, *Anal. Chem.*, 47, 1634 (1975)
2) J.Y.Chang, E.H.Creaser, *J. Chromatogr.*, 116, 215 (1976)
3) J.K.Lin, C.C.Lai, *Anal. Chem.*, 52, 630 (1980)

• p-Bromophenacyl Bromide (PBPB) (UV labeling reagent)

PBPB is a white crystalline, carboxylic acid labeling reagent soluble in alcohol. The melting point is 108–111°C. Using crown ether as the catalyst, fatty acid is reacted with PBPB to form p-bromophenacyl ester. The shorter the alkyl chain length of fatty acids is, the higher sensitivity can be achieved. (E.g., 1 ng propanoic acid, 50 ng stearic acid)

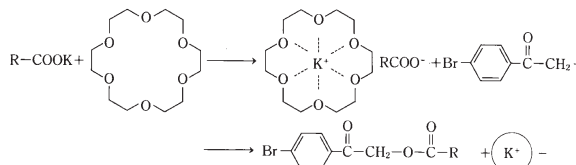
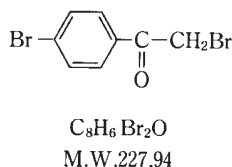

COSMOSIL Application Data

Column: 5C₁₈-MS-II
Column size: 4.6mm I.D.-150mm
Mobile phase: Acetonitrile
Flow rate: 1.0 ml/min
Temperature: 30°C
Detection: UV254nm, 2.56AUFS

Sample: 1; Lauric Acid p-Bromophenacyl Ester
2; Myristic Acid p-Bromophenacyl Ester
3; Palmitic Acid p-Bromophenacyl Ester
4; Stearic Acid p-Bromophenacyl Ester

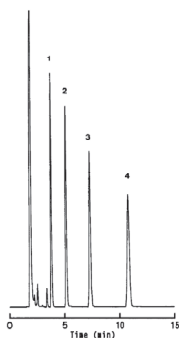

NACALAI TESQUE, INC
AP-0439

E.g.,) Dissolve sample (1 ng propanoic acid, 50 ng stearic acid) as potassium salt in 10 ml acetonitrile. Add mix solution of PBPB and 18-crown-6 (20:1) in the sample solution, and incubate at 80°C for 15 minutes. Cool down the reaction solution to room temperature.

Ref. 1) Durst, H.D., Milano, M., Kikta, E.J., Cinnelly, S.A., Grushka, E., *Anal. Chem.*, 47, 1797 (1975)
2) F.A. Fitzpatrick, *Anal. Chem.*, 48, 499 (1976)
3) P.C. Bossle, J.J. Martin, E.W. Sarver, H.Z. Sommer, *J. Chromatogr.*, 267, 209 (1983)
4) Kihara, S., Rokushika, H., Hatano, *Bunseki Kagaku*, 33, 647 (1984)
5) S. Konosu, A. Shinagawa, K. Yamaguchi, *Bulletin of Japanese Society of Scientific Fisheries*, 52, 869 (1986)

• **3,5-Dinitrobenzoyl Chloride (DNBC) (UV labeling reagent)**

DNBC is a yellow crystalline labeling reagent soluble in alcohol, ether and benzene. The melting point is 67–69°C. DNBC reacts with hydroxyl group (R–OH) to produce 3,5-dinitrobenzoyl ether. It also reacts with amino group (R–NH₂, R–NH–R') to produce 3,5-dinitrobenzamide.

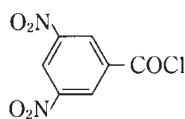

C₇H₃ClN₂O₅
M.W. 230.56

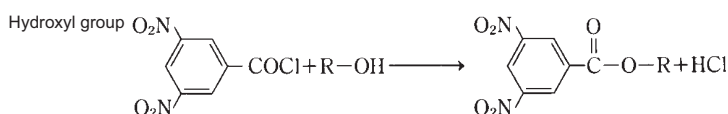

COSMOSIL Application Data

Column: 5C₁₈-MS-II
Column size: 4.6mm I.D.-150mm
Mobile phase: Methanol/ H₂O = 80/20
Flow rate: 1.0 ml/min
Temperature: 30°C
Detection: UV240nm, 0.64AUFS

Sample:
1; 3,5-Dinitrobenzoic Acid n-Propyl Ester
2; 3,5-Dinitrobenzoic Acid n-Butyl Ester
3; 3,5-Dinitrobenzoic Acid n-Pentyl Ester
4; 3,5-Dinitrobenzoic Acid n-Hexyl Ester
5; 3,5-Dinitrobenzoic Acid n-Heptyl Ester
6; 3,5-Dinitrobenzoic Acid n-Octyl Ester

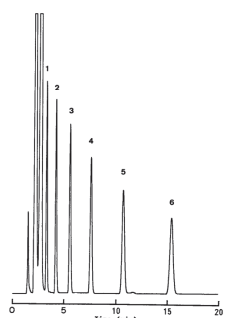

AP-0441

E.g.,) Dissolve a few mg of a sample in 5ml tetrahydrofuran. Add 40 mg of DNBC and 2–3 drops of pyridine, and seal to react at 60°C for 1 hour. Cool down the reaction solution to room temperature. If pyridine or triethylamine is used to eliminate hydrochloric acid, clean up is required before analysis.

How to clean up: Eliminate solvent and extract ether. Wash ether layer with dilute hydrochloric acid and water.

- Ref. 1) T.H.Jupile, *Am.Lab.*, 8, 85 (1976)
2) M.A.Carey, H.E.Persinger, *J.Chromatogr.Sci.*, 10, 573 (1972)
3) Y. Suzuki, N. Tsuchiya, *Bunseki Kagaku*, 30, 240 (1981)
4) L.J.Elrod, L.B.White, S.G.Spanton, D.G.Stroz, P.J.Cugier, L.A.Luka, *Anal.Chem.*, 56, 1786 (1984)

• **NBD Chloride (7-Chloro-4-nitrobenz-2-oxa-1,3-diazole) (Fluorescence-labeling reagent)**

NBD Chloride is a yellow crystallin labeling reagent soluble in alcohol. It is more soluble in water than dansyl chloride. The melting point is 95–98°C. NBD Chloride reacts with amino group (R–NH₂, R–NH–R'). It is also reacts with mercapto group (R–SH).

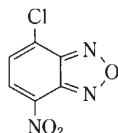

C₆H₂ClN₃O₃

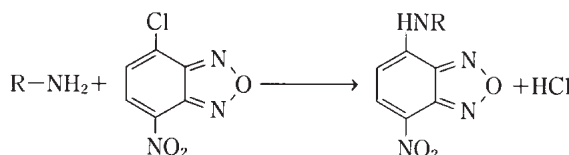

COSMOSIL Application Data

Column: 5C₁₈-MS-II
Column size: 4.6mm I.D.-150mm
Mobile phase: Methanol/ 20mmol/l Phosphoric Acid = 60/40
Flow rate: 1.0 ml/min
Temperature: 30°C
Detection: Ex. 465nm Em. 520nm, RANGE 128

Sample:
1; NBD-Glycine
2; NBD-L-Alanine
3; NBD-L-Valine
4; NBD-L-Leucine

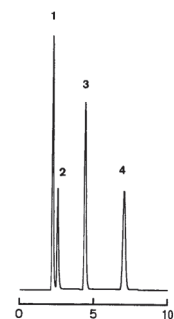

AP-0447

E.g.,) Prepare 25–500 ul of methanol solution containing 1–20 ug of amine. Add 0.05% methanol solution containing 4–8 times higher molar concentration of NBD Chloride than the concentration of amine. Add 50–100 ul of 0.1M sodium hydrogen carbonate, and incubate at 55°C for 1–5 hours. Cool down the reaction solution to room temperature.

- Ref. 1) J.F.Lawrence, R.W.Frei, *Anal.Chem.*, 44, 2046 (1972)
2) H.F.Van, A.Heyndrickx, *Anal.Chem.*, 46, 286 (1974)
3) H.J.Klimisch, L.Stadlen, *J.Chromatogr.*, 90, 141 (1974)
4) J.H.Wolfram, *J.Chromatogr.*, 132, 37 (1977)
5) Y.Nishikawa, K.Kuwata, *Anal.Chem.*, 57, 1864 (1985)

• ***o*-Phthalaldehyde,recryst (OPA) (Fluorescence-labeling reagent)**

OPA is a yellow crystallin labeling reagent soluble in water and most of organic solvents and insoluble in ether. The melting point is 56–57°C. OPA reacts with primary amine and thiol compound.

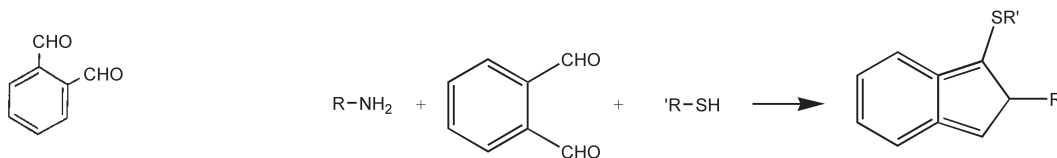

COSMOSIL Application Data

Column: 5C₁₈-MS-II
 Column size: 4.6mm I.D.-150mm
 Mobile phase: Methanol/ 20mmol/l Phosphoric Acid = 70/30
 Flow rate: 1.0 ml/min
 Temperature: 30°C
 Detection: Ex.340nm Em.450nm, RANGE 128

Sample: 1; OPA-Glycine
 2; OPA-L-Alanine
 3; OPA-L-Valine
 4; OPA-L-Leucine

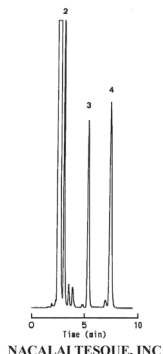

NACALAI TESQUE, INC
 AP-0448

E.g.,) Prepare 0.05ml of 10% hydrochloric acid containing 5 ml of sample as acidic solution. Add 2 ml of 4 mg/ml methanol solution of OPA. Add 0.05 ml of 2-mercaptoethanol and 3 ml of pH9 carbonate buffer. Incubate at room temperature for one minute and filter.

• ***N*-(9-Acridinyl)maleimide (NAM) (Fluorescence-labeling reagent)**

NAM is a yellow crystallin labeling reagent. The melting point is 257–262°C. NAM react with mercapto group.

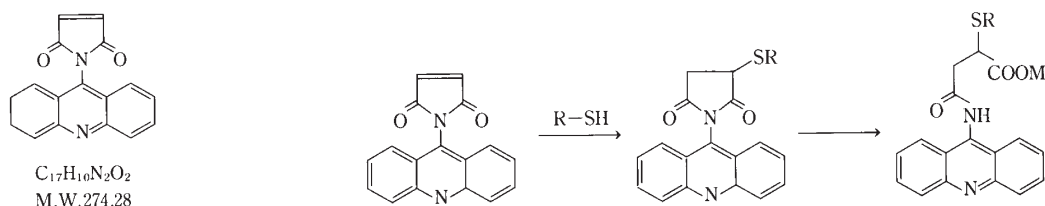

E.g.,) Prepare 2 ml of 1 mmol sample solution containing 0.4ml of 30% sodium hydroxide and 1 ml of 0.2 mol boric acid buffer (pH8.8). Add 0.5 ml of 10 mmol acetone solution of NAM. Incubate at room temperature for 30 minutes.

- Ref. 1) Y.Nara,K.Tujimura,*Agric.Biol.Chem.*,42,793 (1978)
 2) H.Takahashi,Y.Nara,K.Tujimura,*Agric.Biol.Chem.*,43,1493 (1979)
 3) H.Takahashi,T. Yoshida,Meguro,*Bunsekikagaku*,30,339 (1981)

Ordering Information

Product name	Grade	Storage	Product number	PKG Size
Dabsyl Chloride	SP	Room temp.	10427-91	1 g
<i>p</i> -Bromophenacyl Bromide (PBPB)	GR	Refrigerator	05802-92	25 g
3,5-Dinitrobenzoyl Chloride (DNBC)	SP	Dark and Cool	13530-44	5 g
NBD Chloride	SP	Refrigerator	24113-61	1 g
<i>o</i> -Phthalaldehyde (OPA)	SP	Refrigerator	27824-61	1 g
			27824-74	5 g
			27824-32	25 g
<i>N</i> -(9-Acridinyl) maleimide (NAM)	SP	Refrigerator	00842-64	50 mg

3. Column Care Products

Introduction

It is important to preserve a column by washing it with suitable cleaning methods before storing it under appropriate conditions to obtain stable data and prolong the column life time.

Applicable column

Cleaning Solution Kit and Storage Solution for Reversed Phase HPLC Columns are only applicable to reversed phase HPLC columns such as COSMOSIL 5C₁₈-MS-II, AR-II, PAQ, Cholester, πNAP, PYE and PBB-R. Please note that these products are not applicable for Sugar-D, HILIC, Normal phase and Ion Exchange columns.

Cleaning Solution Kit for Reversed Phase HPLC Columns

Components

Product Name	Main Compositions	PKG Size	Quantity	Container
Cleaning Solution A	Methanol	500 ml	2	Brown Glass Bottle
Cleaning Solution B	Tetrahydrofuran, Methanol	500 ml	1	Brown Glass Bottle

Application

Cleaning Solution Kit for Reversed Phase HPLC Columns is designed for washing away contaminant adsorption and stationary phase shedding. If you experience the following symptoms, please try their corresponding solution first.

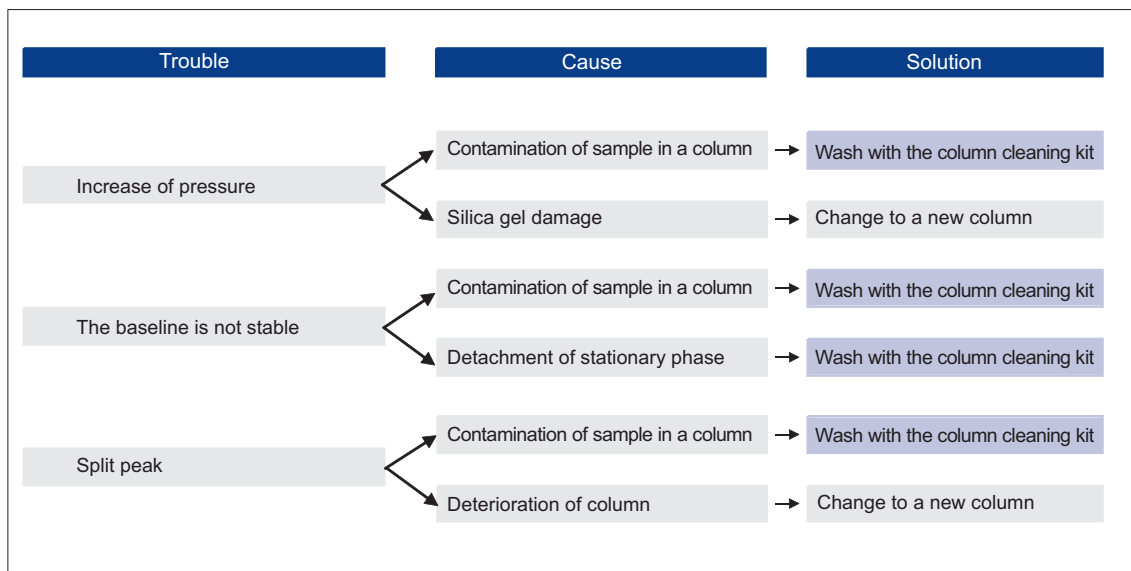

Procedure

(For 4.6 mm I.D. x 150 mm)

- Replace solvent with HPLC-grade distilled water (1 ml/min, 30 min).
(*This step is for mobile phase containing high concentration buffer. If you are using a salt-free mobile phase, please start from step (2).)
- Run the "Cleaning Solution A" through the column for 15 min at a flow rate of 1ml/min.
- Run the "Cleaning Solution B" through the column at a flow rate of 1ml/min until the baseline becomes stable (approx. 15 min).
- Run the "Cleaning Solution A" through the column for 15 min. The column is ready for storage.

Example of pressure difference between washed and unwashed columns

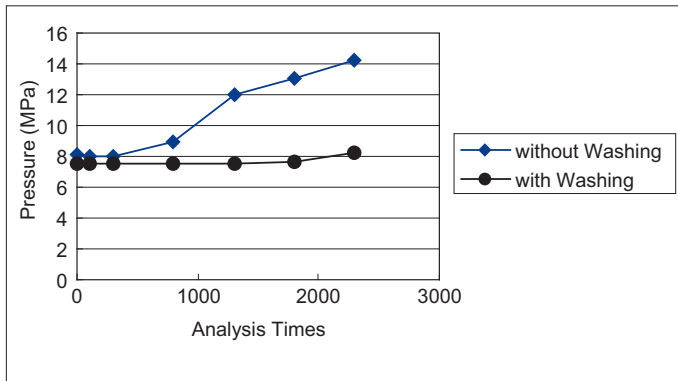

The figure shows pressure comparison between washed and unwashed columns using Cleaning Solution Kit. Repeated analysis of natural products was conducted using COSMOS-IL 5C₁₈-MS-II 4.6 mm I.D. x 150 mm.

(Condition)

Column: COSMOSIL 5C₁₈-MS-II (4.6 mm I.D. x 150 mm)

Mobile phase: Methanol / H₂O = 70 / 30, Flow rate: 1.0ml/min, Temp.: 40°C

As shown in the figure above, the column pressure increases if you use column continuously without washing. If you wash the column, you can extend the column life time and ease the pressure burden on your HPLC equipment.

Example of a Stable Baseline

The baseline may be unstable if sample components with very long retention remain in the column or the stationary phase shedding occurs. Especially when analyzing crude compounds that have components with wide range of chemical characteristics, some unwanted components may be strongly retained in the column and slowly elute out in subsequent runs. The resulting unstable baseline can be eliminated by washing the column with the Cleaning Solution Kit.

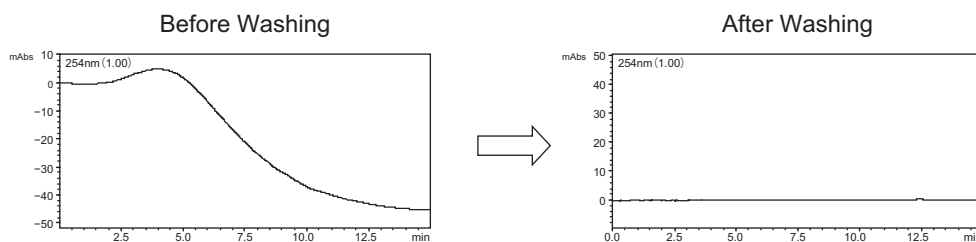

Ordering Information

Product Name	Grade	Product No..	PKG Size
Cleaning Solution for Reversed Phase HPLC Columns	SP	08966-30	1 kit

Storage Solution for Reversed Phase HPLC Columns

Application

Storage Solution for Reversed Phase HPLC Columns is designed for storing column under suitable condition.

Procedure

(For 4.6 mm I.D. x 150 mm)

(1) Replace solvent with HPLC-grade distilled water. (1 ml/min, 30 min)

(*This step is for mobile phase containing high concentration buffer. If you are using a salt-free mobile phase, please start from step(2).)

(2) Run the "Storage Solution" through the column for 15 min at a flow rate of 1ml/min, and store.

Ordering Information

Product Name	Grade	Product No	PKG Size
Storage Solution for Reversed Phase HPLC Columns	SP	08967-20	1 kit (500 ml)

4. COSMOSIL HPLC Accessories

Ordering Information

COSMOSIL Guard Cartridge Holder

Product number	PKG Size
38009-79	1 PKG



Guard Cartridge Holder is required for Guard Cartridge.

COSMOSIL Column Prefilter

Product number	PKG Size
39361-19	1 PKG



COSMOSIL Column Prefilter employs filter with smaller pore size (1 μm) than that of column frit (2 μm).

COSMOSIL Column Spare Filter for Prefilter

Product number	PKG Size
39539-09	2 PKG



Column spare filter for prefilter

COSMOSIL Column Connecting Tube

Product number	PKG Size
37843-69	1 PKG



for connecting columns



Applications



1. COSMOSIL Applications	90
2. Applications of Drug Substances in the Japanese Pharmacopeia, 15th	91
3. COSMOSIL Applications	92
(1) Drugs	92
(2) Crude Drugs	125
(3) Natural Compounds.....	130
(4) Pesticides	133
(5) Food Additives	135
(6) Vitamins.....	137
(7) Metabolites	140
(8) Carbohydrates	142
(9) Lipids	145
(10) Nucleic Acid Related Substances.....	147
(11) Amino Acids, Peptides and Proteins	149
(12) The Others.....	156
4. Reference List	163

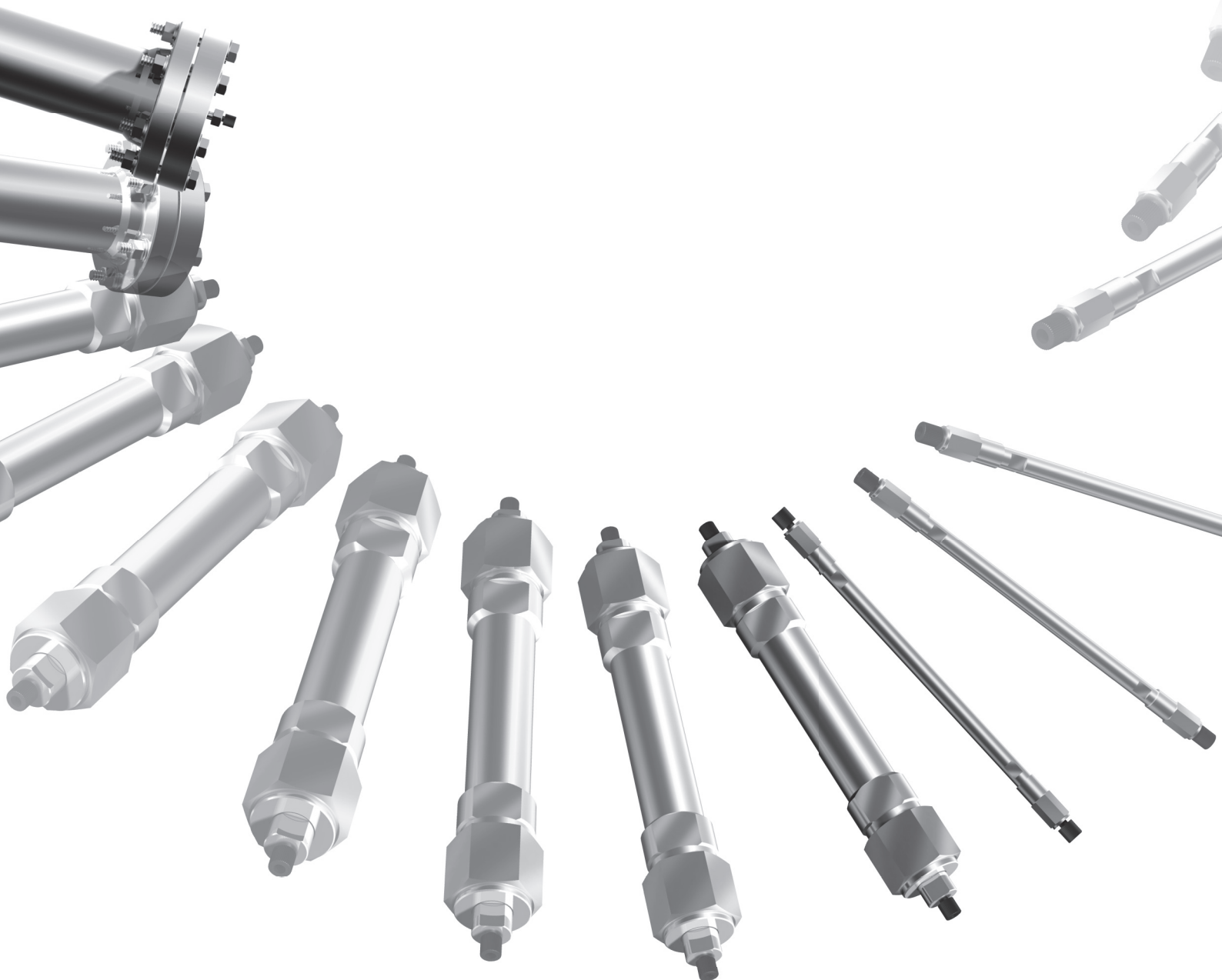

1. COSMOSIL Applications

Introduction

COSMOSIL Application has more than 7,000 applications using COSMOSIL columns. Setting optimal HPLC experimental parameters is the one of the most important processes that requires experience and time. COSMOSIL Application provides you with sample analysis conditions with widely used ODS columns and other specialty columns. For more information, please visit COSMOSIL Application page on our website at <http://www.nacalai.co.jp/global/cosmosil/>.

- Over 7,000 applications
- Easy to search

How to Search

The application is searchable by sample category, sample name, CAS No., column name and particle size. If you have any questions regarding the application or separations of compounds not listed here, please feel free to contact us at info.intl@nacalai.com

COSMOSIL Application Image

COSMOSIL Application, which includes more than 7,000 applications using COSMOSIL columns, is now available. The application is searchable by sample category, sample name, CAS No., column name and particle size. If you have any questions regarding the application or separations of compounds not listed here, please feel free to contact us.

Only show new applications added on Dec. 20th 2011

Category: No Appointment, Amino acids & derivatives, Peptides & Proteins, Nucleic acids & relative compounds, Drugs & related compounds, Antibiotics, Vitamins

Column name: No Appointment, C18-MS-II, C18-AR-II, C18-PAQ, Cholesterol, tTNap, PYE

Sample Name: begins with

CAS number: (ex:498-02-2)

Particle Size: ALL

Result/Page: 20

Search Result

Data No.	Data Name	Sample	Particle Size (µm)	Column	CAS No.
AP-1153	Berberine	Berberine	2.5	C18-MS-II	633-65-8
		Palmitate Chloride			3486-67-7
AP-1153	Berberine	Berberine	2.5	tTNAQ	633-65-8
		Palmitate Chloride			3486-67-7
AP-1024	Berberine	Berberine	5	C18-MS-II	633-65-8
		Palmitate Chloride			3486-67-7
AP-1024	Berberine	Berberine	5	PE-MS	633-65-8
		Palmitate Chloride			3486-67-7
AP-1024	Berberine	Berberine	5	tTNAQ	633-65-8
		Palmitate Chloride			3486-67-7
AP-0964	Phelodendron Bark	Berberine	5	C18-PAQ	633-65-8
		Palmitate Chloride			3486-67-7
AP-0963	Phelodendron Bark	Berberine	5	C18-AR-II	633-65-8
		Palmitate Chloride			3486-67-7
AP-0962	Phelodendron Bark	Berberine	5	C18-MS-II	633-65-8
		Palmitate Chloride			3486-67-7
A-80090	Index	Berberine	5	C18-AR-II	633-65-8
M-80090	Index	Berberine	5	C18-MS-II	633-65-8

An Example of the COSMOSIL Application

COSMOSIL Chromatogram INDEX has been combined with COSMOSIL Application, Features are shown below respectively.

Applications of each sample category or comparison by each column

COSMOSIL Application Data

Column: SC₂-MS-II
 Column size: 4.6x150-3.0mm
 Mobile phase: Acetonitrile / Normal 5 Sodium Lauryl Sulfate
 Gradient: 0.5% to 100%
 Flow rate: 1.0 ml/min
 Temperature: 40°C
 Detection: UV-254nm
 Sample: 1. Berberine (1.0 µg)
 2. Berberine (1.0 µg)

Chromatograms and structure of each compound

COSMOSIL Application Data

Column: SC₂-PAQ
 Column size: 4.6x150-3.0mm
 Mobile phase: Acetonitrile / Normal 5 Sodium Lauryl Sulfate
 Gradient: 0.5% to 100%
 Flow rate: 1.0 ml/min
 Temperature: 40°C
 Detection: UV-254nm
 Sample: 1. Berberine (1.0 µg)
 2. Berberine (1.0 µg)

2. Applications of Drug Substances in the Japanese Pharmacopoeia, 15th

Introduction

We have prepared drug analysis HPLC data using three different COSMOSIL C₁₈ columns as specified in Japanese Pharmacopoeia, 15th version. 5 μm silica gel column size 4.6mm I.D. x 150 mm or 250 mm were used with reagent grade samples. Furthermore, we analyzed reference drug substances with internal standard and impurities. The data are available at our web site at <http://www.nacalai.co.jp/global/cosmosil/>, or search "COSMOSIL Japanese Pharmacopoeia" on the web. An example of the application is shown after page 92.

Interpretation of Application

THE JAPANESE PHARMACOPOEIA (Fifteenth Edition) JP15
-001

1

Acetaminophen (Purity)

Acetaminophen [103-90-2]

C₈H₉NO₂: 151.16

N-(4-Hydroxyphenyl) acetamide

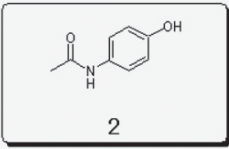
2

	5C ₁₈ -MS-II	5C ₁₈ -AR-II	5C ₁₈ -PAQ
3	10.7	10.5	11.2
Suitability	○	○	○
5	recommendation		

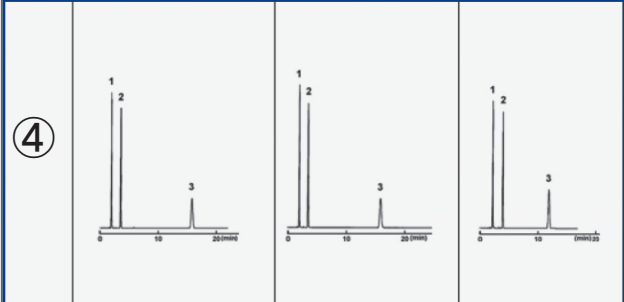
4

Column size 4.6 mm I.D. x 150 mm

Mobile phase Methanol : 0.05 mol/L potassium dihydrogenphosphate (pH 4.7) = 20 : 80

Temperature 40°C

Detection UV 225 nm

Flow rate 1.0 mL/min

Sample 1: p-Aminophenol Hydrochloride (0.02 mg/mL) [Internal standard]
2: Acetaminophen (0.02 mg/mL) [Purity sample]
3: 4-Acetoxyacetamide (0.02 mg/mL) [Impurity]

Test solution Mobile phase

Injection volume 10 μL

[Items described in The Japanese Pharmacopoeia]
(Flow rate) Adjust the flow rate so that the retention time of Sample 2 is about 5 minutes.
(Selection of column) (*)
Use a column eluting off Sample 1 before Sample 2, and resolution (R_s) between those 2 peaks should not be less than 7.
(Detection sensitivity)
Adjust the detection sensitivity so that the peak height of Sample 2 obtained from 10 μL of the standard solution is about 15% of the full scale.
(Time span of measurement)
About 6 times as long as the retention time of Sample 2 after the solvent peak.
(Point to notice)
* 0.05 mol/L potassium dihydrogenphosphate (pH 4.7)
Dissolve 6.80 g of potassium dihydrogenphosphate in 900 mL of water, adjust pH to exactly 4.7 with dilute sodium hydroxide test solution, and add water to make 1000 mL solution.

6

NACALAI TESQUE, INC

- ① Substance Name
- ② Substance Information
- ③ Suitability (○ : suitable, × : unsuitable, ** : depend on condition)
- ④ HPLC Chromatogram
- ⑤ Recommended Column

Recommended column is determined by resolution of internal standard substances or impurities, theoretical plate number, peak symmetry of the target sample and analysis conditions.
- ⑥ Condition and Japanese Pharmacopoeia Description

3. COSMOSIL Applications

(1) Drugs	Page 92 (Application data of substances in Japanese Pharmacopoeia page 92-121, page 125-129)
(2) Crude Drugs	Page 125
(3) Natural Compounds	Page 130
(4) Pesticides	Page 133
(5) Food Additives	Page 135
(6) Vitamins	Page 137
(7) Metabolites	Page 140
(8) Carbohydrates	Page 142
(9) Lipids	Page 145
(10) Nucleic Acid Related Substances	Page 147
(11) Amino Acids, Peptides and Proteins	Page 149
(12) The Others	Page 156

(1) Drugs

● Acrinol

COSMOSIL Application Data

Column: 5C₁₈-PAQ
 Column size: 4.6mm I.D.-250mm
 Mobile phase: Acetonitrile/ 4.6mmol/l Sodium
 7-Octanesulfonate, 65mmol/l NaH₂PO₄
 (pH2.8 with H₃PO₄) = 30/70
 Flow rate: 1.0 ml/min
 Temperature: 25°C
 Detection: UV268nm

Sample:
 1; 6,9-Diamino-2-ethoxyacridine Lactate
 [Acrinol] (0.04µg)

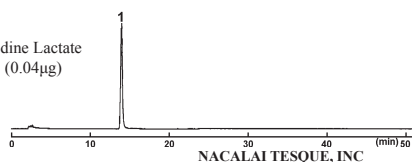

AP-0457

● Azathioprine

COSMOSIL Application Data

Column: 5C₁₈-AR-II
 Column size: 4.6mm I.D.-150mm
 Mobile phase: Methanol/ 25mmol/l KH₂PO₄
 (pH2.5 with H₃PO₄) = 20/80
 Flow rate: 1.0 ml/min
 Temperature: 40°C
 Detection: UV296nm

Sample: 1; 6-Mercaptopurine (0.16µg)
 2; Azathioprine (0.16µg)
 3; Benzoic Acid (9.6µg)

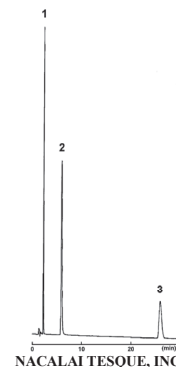

AP-0471

● Aztreonam

COSMOSIL Application Data

Column: 5C₁₈-AR-II
 Column size: 4.6mm I.D.-250mm
 Mobile phase: Methanol/ 5mmol/l Tetra-*n*-butylammonium
 Hydrogensulfate (pH3.0 with 0.5mol/l Na₂HPO₄)
 = 35/65
 Flow rate: 1.0 ml/min
 Temperature: 40°C
 Detection: UV280nm

Sample: 1; *p*-Aminobenzoic Acid (0.5µg)
 2; Aztreonam (5.0µg)

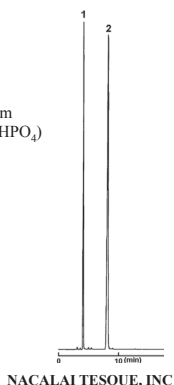

AP-0474

● Acetaminophen

COSMOSIL Application Data

Column: 5C₁₈-MS-II
 Column size: 4.6mm I.D.-150mm
 Mobile phase: Methanol/ 50mmol/l KH₂PO₄
 (pH4.7 with NaOH) = 20/80
 Flow rate: 1.0 ml/min
 Temperature: 40°C
 Detection: UV225nm

Sample: 1; *p*-Aminophenol (0.2µg)
 2; *p*-Acetamidophenol (0.2µg)
 3; 4'-Acetoxyacetanilide (0.2µg)

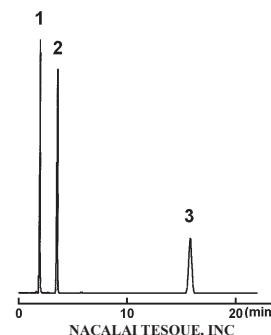

AP-0452

● Atenolol

COSMOSIL Application Data

Column: 5C₁₈-AR-II
 Column size: 4.6mm I.D.-150mm
 Mobile phase: Methanol/Tetrahydrofuran/
 4.6mmol/l Sodium *I*-Octanesulfonate,
 1.2mmol/l Tetra-*n*-butylammonium Hydrogensulfate,
 25mmol/l KH₂PO₄(pH3.0 with H₃PO₄)
 = 9/1/40
 Flow rate: 1.0 ml/min
 Temperature: 25°C
 Detection: UV226nm
 Sample: 1; Atenolol (0.1µg)

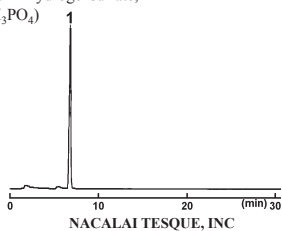

● Amikacin Sulfate

COSMOSIL Application Data

Column: 5C₁₈-PAQ
 Column size: 4.6mm I.D.-250mm
 Mobile phase: Methanol/ 20mmol/l KH₂PO₄
 (pH6.5 with KOH) = 72/28
 Flow rate: 1.5 ml/min
 Temperature: 35°C
 Detection: UV340nm

Sample:
 1; Amikacin Sulfate 2,4,6-trinitrobenzenesulfonic
 Acid Derivative (0.6µg)
 2; Kanamycin Sulfate 2,4,6-trinitrobenzenesulfonic
 Acid Derivative (0.6µg)

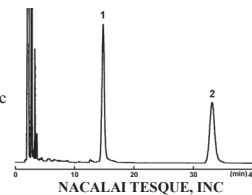

● Meglumine Sodium Amidotrizoate

COSMOSIL Application Data

Column: 5C₁₈-MS-II
 Column size: 4.6mm I.D.-250mm
 Mobile phase: Acetonitrile/ 6.25mmol/l Tetra-*n*-butylammonium
 Phosphate, 50mmol/l K₂HPO₄
 (pH7.0 with H₃PO₄) = 20/80
 Flow rate: 1.0 ml/min
 Temperature: 25°C
 Detection: UV254nm
 Sample: 1; Diatrizoic Acid (0.25µg)
 2; Acetrizoic Acid (0.30µg)

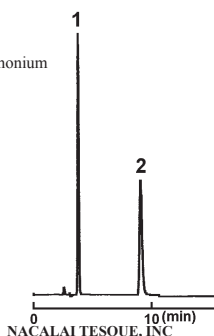

● Amlodipine Besilate

COSMOSIL Application Data

Column: 5C₁₈-MS-II
 Column size: 4.6mm I.D.-150mm
 Mobile phase: Methanol/ 30mmol/l KH₂PO₄ = 65/35
 Flow rate: 0.5 ml/min
 Temperature: 30°C
 Detection: UV237nm

Sample: 1; Amlodipine (0.56µg)
 2; Isobutyl *p*-Hydroxybenzoate (0.60µg)

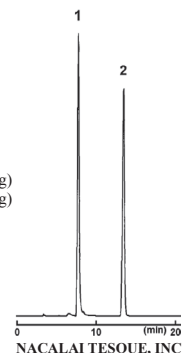

● Amoxicillin

COSMOSIL Application Data

Column: 5C₁₈-PAQ
 Column size: 4.6mm I.D.-150mm
 Mobile phase: Methanol/ 10mmol/l CH₃COONa
 (pH4.5 with CH₃COOH) = 5/95
 Flow rate: 1.0 ml/min
 Temperature: 30°C
 Detection: UV230nm

Sample: 1; Amoxicillin (3.0µg)

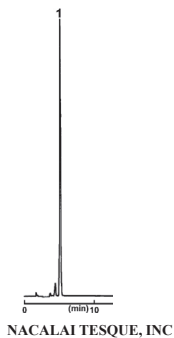

● Ampicillin

COSMOSIL Application Data

Column: 5C₁₈-MS-II
 Column size: 4.6mm I.D.-150mm
 Mobile phase: 10% Acetonitrile/ 90% 50mmol/l
 (NH₄)₂HPO₄ (pH5.0 with H₃PO₄)
 Flow rate: 1.0 ml/min
 Temperature: 25°C
 Detection: UV230nm

Sample: 1; Ampicillin (10µg)
 2; Guaiacol Glycerol Ether (5µg)

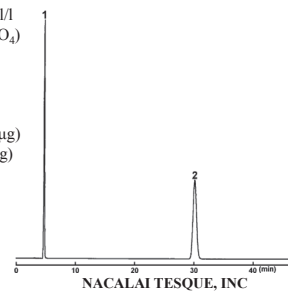

(1) Drugs

● Isoxsuprine Hydrochloride

COSMOSIL Application Data

Column: 5C₁₈-MS-II
Column size: 4.6mmI.D.-150mm
Mobile phase: Methanol/ 32.6mmol/l (NH₄)₂HPO₄,
18.4mmol/l Sodium *I* - Pentanesulfonate
(pH2.5 with H₃PO₄) = 40/60
Flow rate: 1.0 ml/min
Temperature: 40°C
Detection: UV269nm

Sample: 1; Isoxsuprine (2.0µg)



NACALAI TESQUE, INC

AP-1103

● Isoniazid

COSMOSIL Application Data

Column: 5C₁₈-MS-II
Column size: 4.6mmI.D.-250mm
Mobile phase: 10mmol/l-Sodium *I*-Tridecanesulfonate-
Methanol/ 50mmol/l Phosphate buffer
(pH2.5) =60/40

Flow rate: 0.5 ml/min
Temperature: 40°C
Detection: UV265nm

Sample: 1; Isonicotinic Acid
[Pyridine-4-carboxylic Acid] (0.4µg)
2; Isonicotinic Hydrazide
[Isoniazid] (0.5µg)

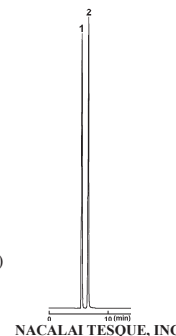

NACALAI TESQUE, INC

AP-0702

● Idoxuridine

COSMOSIL Application Data

Column: 5C₁₈-PAQ
Column size: 4.6mmI.D.-150mm
Mobile phase: Methanol/ H₂O = 13/87
Flow rate: 1.0 ml/min
Temperature: 30°C
Detection: UV254nm

Sample: 1; 2'-Deoxyuridine (0.3µg)
2; 5-Iodouracil (1.2µg)
3; 5-Iododeoxyuridine
[Idoxuridine] (3.0µg)
4; Sulfathiazole (0.5µg)

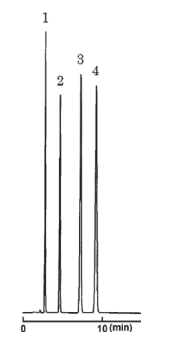

NACALAI TESQUE, INC

AP-0694

● Idoxuridine

COSMOSIL Application Data

Column: 5C₁₈-PAQ
Column size: 4.6mmI.D.-150mm
Mobile phase: Methanol/ H₂O = 4/96
Flow rate: 1.0 ml/min
Temperature: 30°C
Detection: UV254nm

Sample: 1; 2'-Deoxyuridine (0.04µg)
2; 5-Iodouracil (0.12µg)
3; 5-Iododeoxyuridine
[Idoxuridine] (0.40µg)

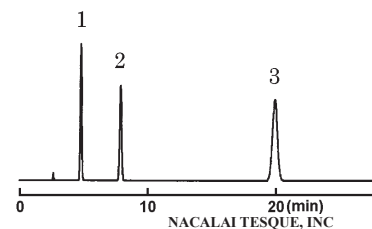

NACALAI TESQUE, INC

AP-0697

● Ipratropium Bromides

COSMOSIL Application Data

Column: 5C₈-MS
Column size: 4.6mmI.D.-150mm
Mobile phase: Acetonitrile/ 0.5% H₃PO₄/
Methanesulfonic Acid = 120/1000/10
Flow rate: 1.0 ml/min
Temperature: 30°C
Detection: UV210nm

Sample: 1; Ipratropium Bromide Derivative
2; Ipratropium Bromide

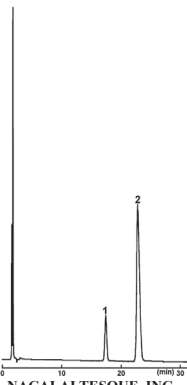

NACALAI TESQUE, INC

AP-0701

● Indomethacin

COSMOSIL Application Data

Column: 5C₁₈-MS-II
Column size: 4.6mmI.D.-250mm
Mobile phase: Methanol/ 0.1% H₃PO₄ = 80/20
Flow rate: 1.0 ml/min
Temperature: 25°C
Detection: UV254nm

Sample: 1; 4-Chlorobenzoic Acid (1.0µg)
2; Butyl *p*-Hydroxybenzoate (0.6µg)
3; Indometacin(Indomethacin) (1.0µg)

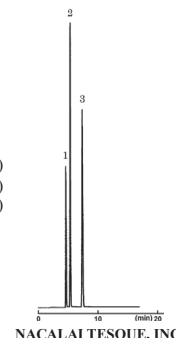

NACALAI TESQUE, INC

AP-0698

● Estradiol Benzoate

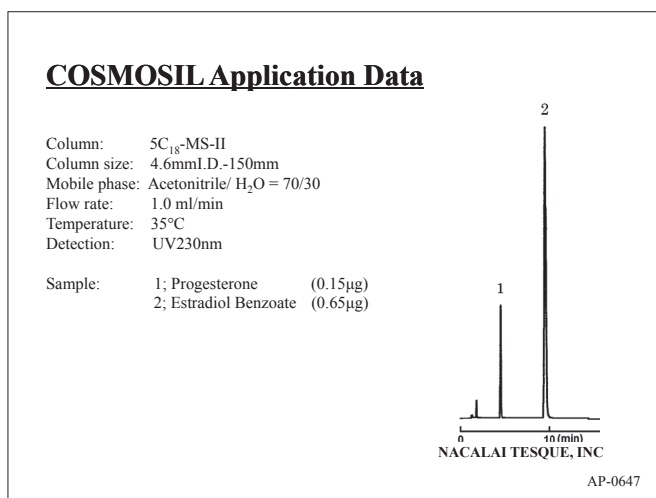

● Estriol

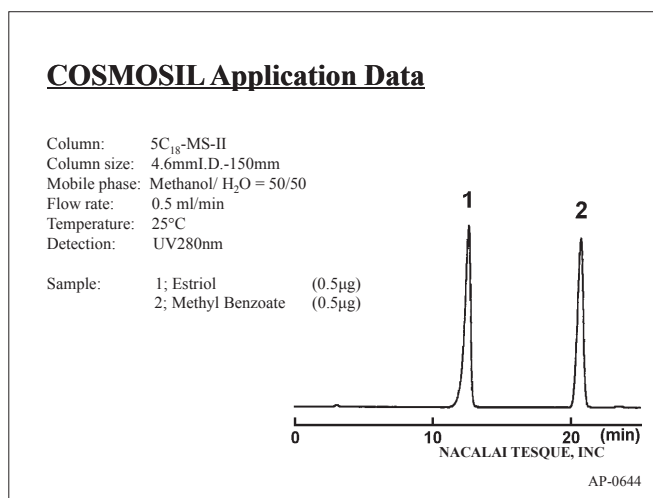

● Epirubicin Hydrochloride

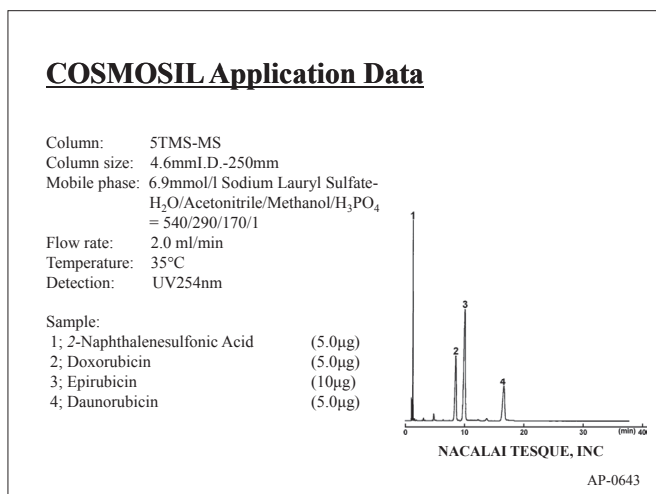

● Oxytocin

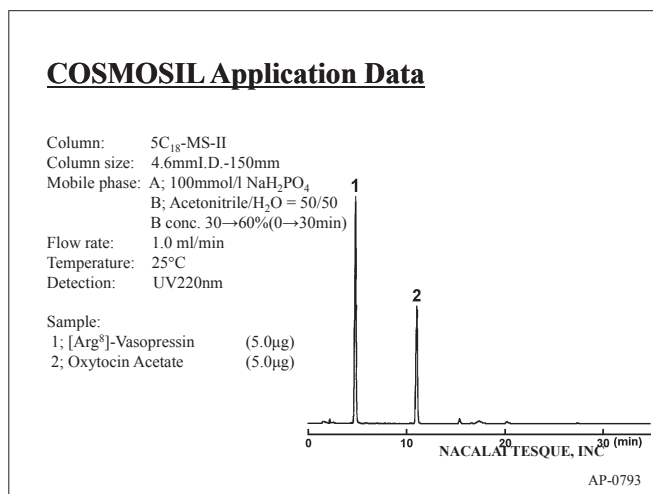

● Omeprazole

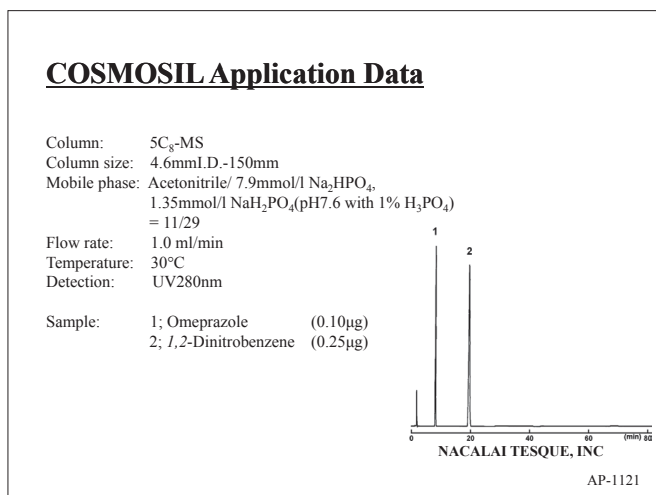

● Captopril

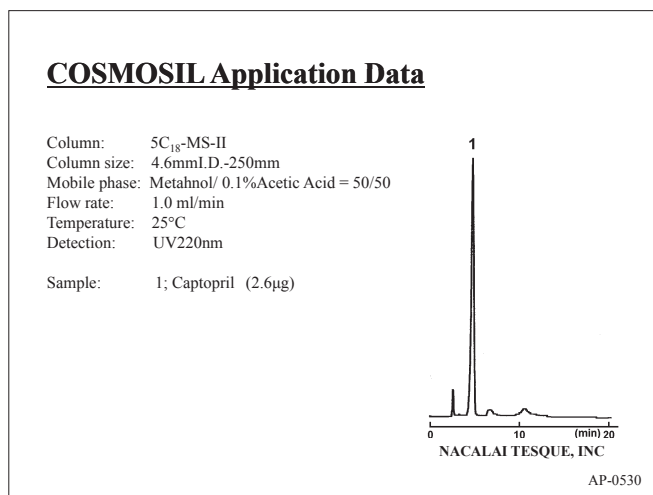

(1) Drugs

● Gabexate Mesilate

COSMOSIL Application Data

Column: 5C₁₈-MS-II
Column size: 4.6mmI.D.-150mm
Mobile phase: Methanol/ (0.1% Sodium Lauryl Sulfate/
0.5% Sodium *I*-Heptanesulfonate/
Acetic Acid = 200/20/1) = 71/29
Flow rate: 0.5 ml/min
Temperature: 25°C
Detection: UV245nm

Sample: 1; Ethyl *p*-Hydroxybenzoate (0.39µg)
2; Butyl *p*-Hydroxybenzoate (0.39µg)
3; Gabexate Mesilate (0.75µg)

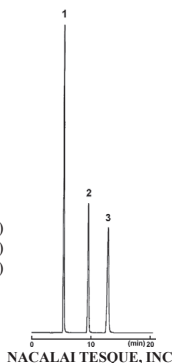

NACALAI TESQUE, INC

AP-0673

● Camostat Mesilate

COSMOSIL Application Data

Column: 5C₁₈-AR-II
Column size: 4.6mmI.D.-150mm
Mobile phase: Methanol/ (0.2% Sodium *I*-Heptane Sulfonate/
0.1% Sodium Lauryl Sulfate/ Acetic Acid
= 1000/500/10) = 55/45
Flow rate: 1.0 ml/min
Temperature: 25°C
Detection: UV265nm

Sample: 1; Camostat (1.02µg)
2; Butyl *p*-Hydroxybenzoate (0.54µg)

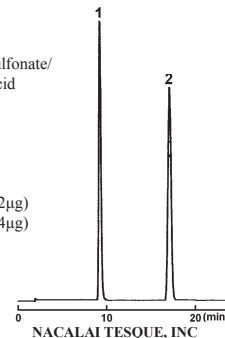

NACALAI TESQUE, INC

AP-0528

● Carbazochrome Sodium Sulfonate

COSMOSIL Application Data

Column: 5C₁₈-PAQ
Column size: 4.6mmI.D.-250mm
Mobile phase: Ethanol/ 10.4mmol/l (NH₄)₂HPO₄
= 75/925(pH7 with H₃PO₄)
Flow rate: 1.0 ml/min
Temperature: 40°C
Detection: UV360nm

Sample: 1; Carbazochrome Sodium Sulfonate (1.0µg)
2; Carbazochrome (1.0µg)

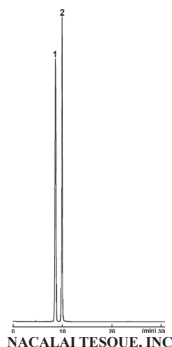

NACALAI TESQUE, INC

AP-0535

● Carbidopa

COSMOSIL Application Data

Column: 5C₁₈-PAQ
Column size: 4.6mmI.D.-250mm
Mobile phase: Ethanol/ 50mmol/l NaH₂PO₄ = 5/95
(pH2.7 with H₃PO₄)
Flow rate: 1.0 ml/min
Temperature: 30°C
Detection: UV280nm

Sample: 1; (-)-3-(3,4-Dihydroxyphenyl)-2-Methyl-L-Alanine
[L- α -Methyl DOPA] (10µg)
2; S(-)-Carbidopa (10µg)

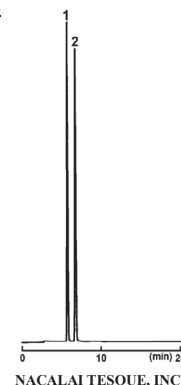

NACALAI TESQUE, INC

AP-0538

● Quinidine Sulfate and Quinine Hydrochloride

COSMOSIL Application Data

Column: 5C₁₈-PAQ
Column size: 4.6mmI.D.-250mm
Mobile phase: Acetonitrile/ 0.088% Acetic Acid,
0.16% Methanesulfonic Acid,
0.22% Diethylamine = 10/90
Flow rate: 1.0 ml/min
Temperature: 30°C
Detection: UV235nm

Sample: 1; Cinchonidine (1.0µg)
2; Quinidine (10µg)
3; Quinine (10µg)
4; Hydroquinidine (10µg)
5; Dihydroquinine

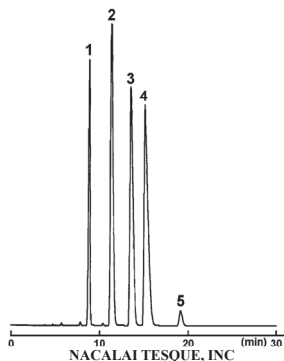

NACALAI TESQUE, INC

AP-0828

● Potassium Clavulanate

COSMOSIL Application Data

Column: 5C₁₈-PAQ
Column size: 4.6mmI.D.-150mm
Mobile phase: A; 50mmol/l NaH₂PO₄(pH4.0 with H₃PO₄)
B; Methanol/ 50mmol/l NaH₂PO₄
(pH4.0 with H₃PO₄) = 50/50
B conc. 0%(0-4 min), 0→100%(4→15 min),
100%(15-25min)
Flow rate: 1.0 ml/min
Temperature: 40°C
Detection: UV230nm

Sample: 1; Clavulanic Acid
2; Amoxicillin

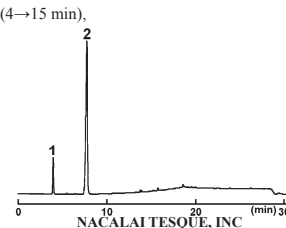

NACALAI TESQUE, INC

AP-0810

● Clarithromycin

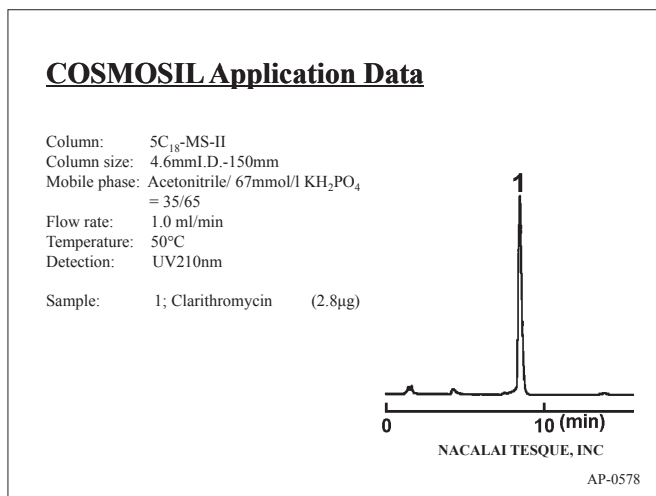

● Griseofulvin

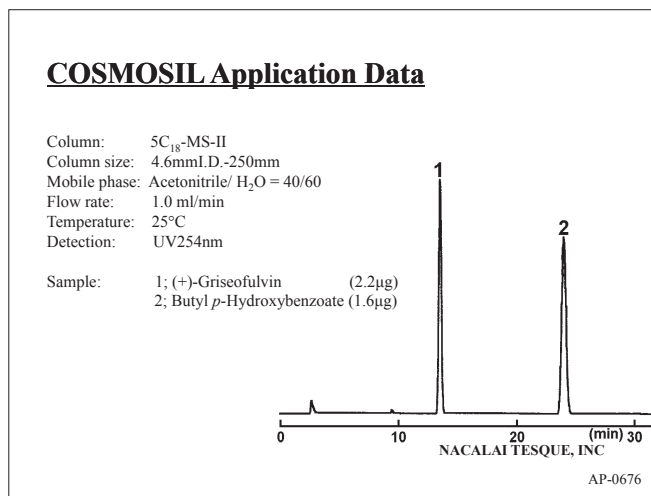

● Clindamycin Phosphate

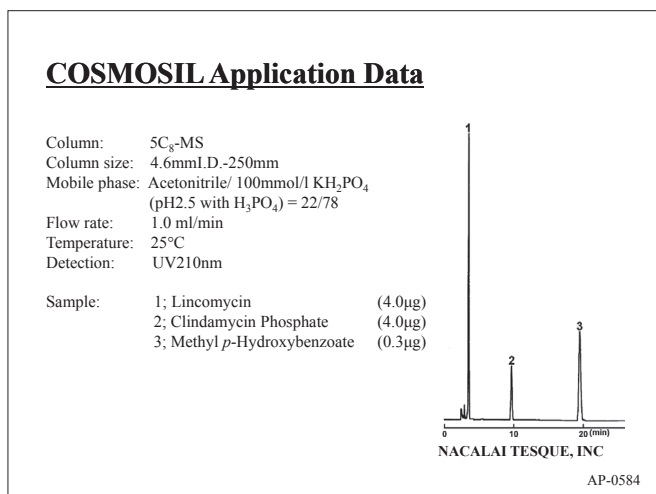

● Clindamycin Hydrochloride

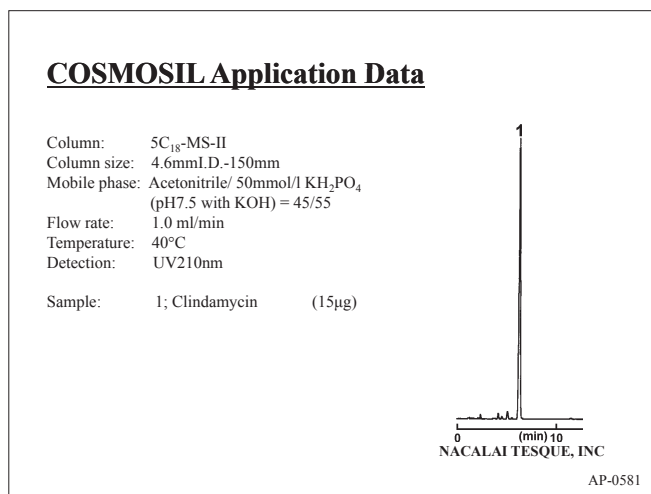

● Cloxacillin Sodium

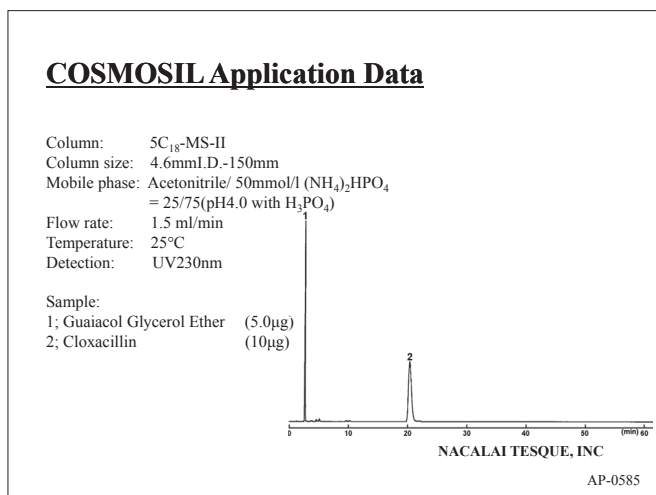

● Clofibrate

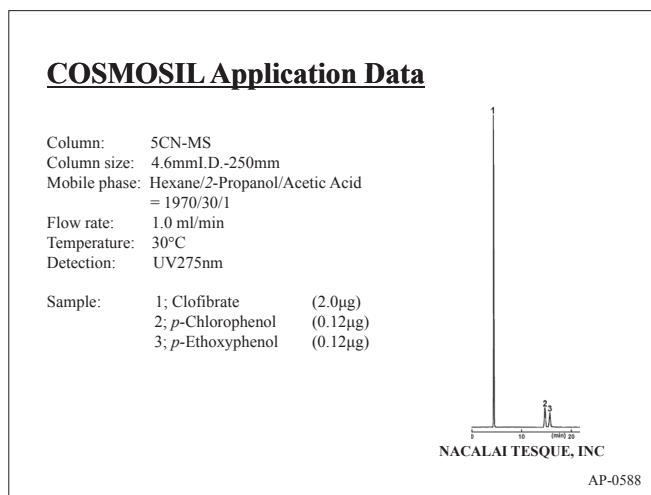

(1) Drugs

● Clofibrate

COSMOSIL Application Data

Column: 5C₁₈-AR-II
Column size: 4.6mmI.D.-250mm
Mobile phase: Acetonitrile/ 0.1%Acetic Acid = 60/40
Flow rate: 1.5 ml/min
Temperature: 25°C
Detection: UV275nm

Sample: 1; 4-Chlorophenol (4.0µg)
2; Ibuprofen (60µg)
3; Clofibrate (10µg)

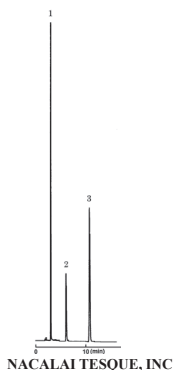

NACALAI TESQUE, INC

AP-0590

● Clobetasol Propionate

COSMOSIL Application Data

Column: 5C₁₈-MS-II
Column size: 4.6mmI.D.-150mm
Mobile phase: Acetonitrile/ Methanol/ 50mmol/l NaH₂PO₄
(pH2.5 with H₃PO₄) = 47.5/10/42.5
Flow rate: 1.0 ml/min
Temperature: 30°C
Detection: UV240nm

Sample: 1; Clobetasol Propionate (1.0µg)
2; Beclomethasone Dipropionate (2.0µg)

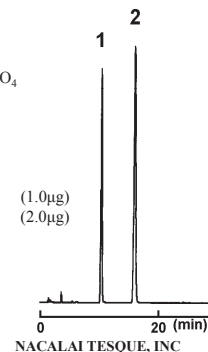

NACALAI TESQUE, INC

AP-1098

● Cloperastine Hydrochloride

COSMOSIL Application Data

Column: 5C₁₈-AR-II
Column size: 4.6mmI.D.-150mm
Mobile phase: Methanol/ 100mmol/l KH₂PO₄,
0.16%Perchloric Acid = 60/40
Flow rate: 1.0 ml/min
Temperature: 25°C
Detection: UV222nm

Sample: 1; Cloperastine (0.2µg)
2; Benzophenone (0.4µg)
3; 4-Chlorobenzophenone (0.2µg)

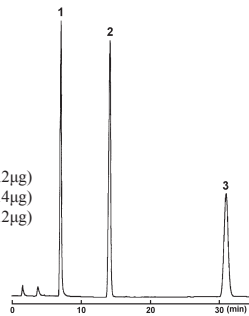

NACALAI TESQUE, INC

AP-0593

● Chlorpheniramine Maleate

COSMOSIL Application Data

Column: 5C₁₈-PAQ
Column size: 4.6mmI.D.-250mm
Mobile phase: Acetonitrile/ 74.5mmol/l (NH₄)H₂PO₄,
14.7mmol/l H₃PO₄ = 20/80
Flow rate: 1.0 ml/min
Temperature: 25°C
Detection: UV225nm

Sample: 1; Maleic Acid (Impurity)
2; Chlorpheniramine (0.06µg)

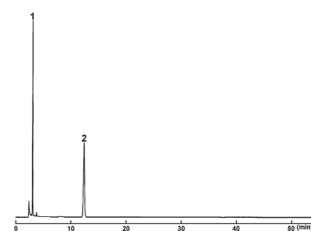

NACALAI TESQUE, INC

AP-0568

● Chlorpropamide

COSMOSIL Application Data

Column: 5C₁₈-AR-II
Column size: 4.6mmI.D.-250mm
Mobile phase: Acetonitrile/ 1%Acetic Acid = 50/50
Flow rate: 1.0 ml/min
Temperature: 25°C
Detection: UV240nm

Sample: 1; 1-(*p*-Chlorophenylsulfonyl)-3-Propylurea
[Chlorpropamide] (1.0µg)

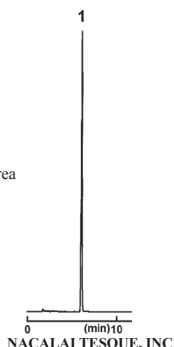

NACALAI TESQUE, INC

AP-0570

● Chlormadinone Acetate

COSMOSIL Application Data

Column: 5C₁₈-MS-II
Column size: 4.6mmI.D.-150mm
Mobile phase: Acetonitrile/H₂O = 65/35
Flow rate: 0.5 ml/min
Temperature: 30°C
Detection: UV236nm

Sample: 1; Butyl *p*-Hydroxybenzoate (0.2µg)
2; 17 α -Hydroxyprogesterone 17-Acetate (0.2µg)
3; Chlormadinone Acetate (0.8µg)

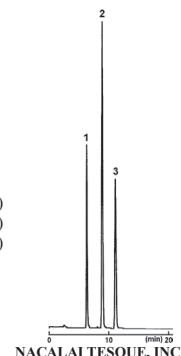

NACALAI TESQUE, INC

AP-0563

(1) Drugs

• Ketoprofen

COSMOSIL Application Data

Column: 5C₁₈-AR-II
Column size: 4.6mm I.D.-150mm
Mobile phase: Acetonitrile/H₂O/ 0.5mol KH₂PO₄
(pH 3.5 with H₃PO₄) = 43/55/2
Flow rate: 1.0 ml/min
Temperature: 25°C
Detection: UV233nm

Sample: 1; Ketoprofen (0.4µg)

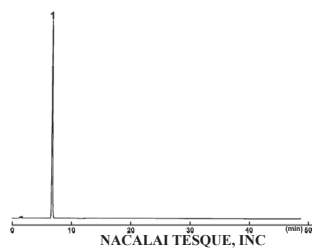

• Cortisone

COSMOSIL Application Data

Column: 5C₁₈-MS-II
Column size: 4.6mm I.D.-150mm
Mobile phase: A; Acetonitrile/ H₂O = 30/70
B; Acetonitrile/ H₂O = 70/30
B conc. 10%(0-5min)
10→90%(5→25min)
90%(25-30min)

Flow rate: 1.0 ml/min
Temperature: 30°C
Detection: UV254nm

Sample:
1; Cortisone (3.6µg)
2; Cortisone 21-Acetate (3.75µg)
3; Hydrocortisone Acetate (3.6µg)

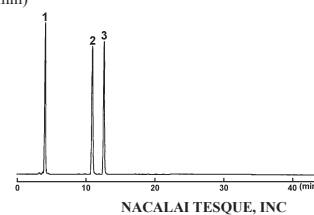

• Salicylic Acid

COSMOSIL Application Data

Column: 5C₁₈-AR-II
Column size: 4.6mm I.D.-150mm
Mobile phase: Methanol/ 1.67% Acetic Acid = 40/60
Flow rate: 0.5 ml/min
Temperature: 35°C
Detection: UV270nm

Sample: 1; *p*-Hydroxybenzoic Acid (0.025µg)
2; Phenol (0.10µg)
3; Salicylic Acid (0.50µg)

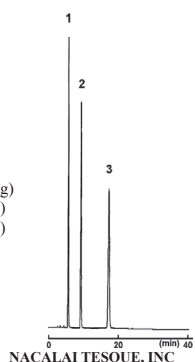

• Santonin

COSMOSIL Application Data

Column: 5C₁₈-MS-II
Column size: 4.6mm I.D.-150mm
Mobile phase: Methanol/H₂O = 50/50
Flow rate: 1.0 ml/min
Temperature: 25°C
Detection: UV254nm

Sample: 1; α -Santonin (0.50µg)
2; Ethyl *p*-Hydroxybenzoate (0.24µg)

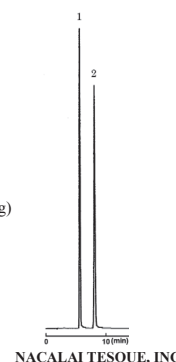

• Cyanocobalamins

COSMOSIL Application Data

Column: 5C₈-MS
Column size: 4.6mm I.D.-250mm
Mobile phase: Methanol/ 70mmol/l Na₂HPO₄
(pH 3.5 with H₃PO₄) = 53/147
Flow rate: 1.0 ml/min
Temperature: 30°C
Detection: UV361nm

Sample: 1; Vitamin B₁₂ [Cyanocobalamin]
2; Cyanocobalamin Derivative

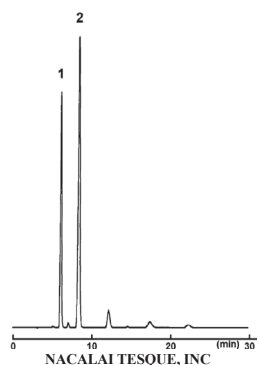

• Digitoxin

COSMOSIL Application Data

Column: 5C₁₈-PAQ
Column size: 4.6mm I.D.-150mm
Mobile phase: Methanol/ H₂O = 75/25
Flow rate: 1.0 ml/min
Temperature: 30°C
Detection: UV230nm

Sample: 1; Digoxin (1.0µg)
2; Gitoxin (0.5µg)
3; Digitoxin (0.5µg)
4; Acenaphthene (0.03µg)

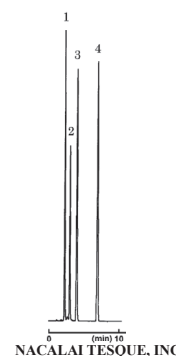

(1) Drugs

● Cyclosporin

COSMOSIL Application Data

Column: 5C₁₈-PAQ
Column size: 4.6mmI.D.-250mm
Mobile phase: Acetonitrile/ 0.22% H_2PO_4 /
tert-Butyl Methyl Ether = 50/45/5
Flow rate: 1.0 ml/min
Temperature: 50°C
Detection: UV210nm

Sample: 1; Ciclosporin [Cyclosporin] (24 μg)

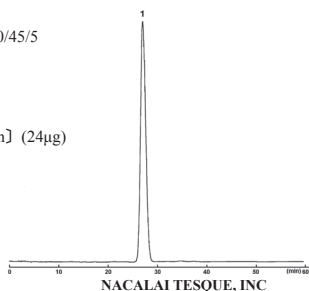

NACALAI TESQUE, INC

AP-0574

● Diclofenac Sodium

COSMOSIL Application Data

Column: 5C₁₈-AR-II
Column size: 4.6mmI.D.-250mm
Mobile phase: Methanol/ 0.12%Acetic Acid = 70/30
Flow rate: 0.5 ml/min
Temperature: 40°C
Detection: UV240nm

Sample:
1; Ethyl *p*-Hydroxybenzoate (0.14 μg)
2; *n*-Propyl *p*-Hydroxybenzoate (0.2 μg)
3; Diclofenac (0.4 μg)

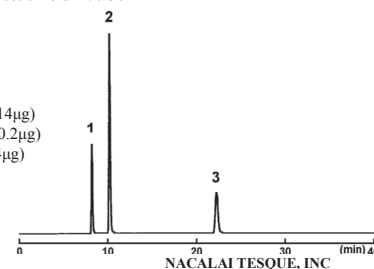

NACALAI TESQUE, INC

AP-0613

● Diclofenamide

COSMOSIL Application Data

Column: 5C₁₈-MS-II
Column size: 4.6mmI.D.-250mm
Mobile phase: Acetonitrile/ 40mmol/l Na_2HPO_4 ,
52mmol/l NaH_2PO_4 = 50/50
Flow rate: 0.5 ml/min
Temperature: 30°C
Detection: UV280nm

Sample:
1; Dichlorophenamide (10 μg)
2; Butyl *p*-Hydroxybenzoate (1.2 μg)

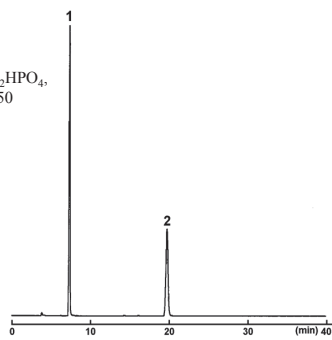

NACALAI TESQUE, INC

AP-0615

● Disulfiram

COSMOSIL Application Data

Column: 5C₁₈-MS-II
Column size: 4.6mmI.D.-150mm
Mobile phase: Methanol/ H_2O = 70/30
Flow rate: 1.0 ml/min
Temperature: 25°C
Detection: UV210nm

Sample:
1; Benzophenone (0.05 μg)
2; Tetraethylthiuram Disulfide
[Disulfiram] (0.05 μg)

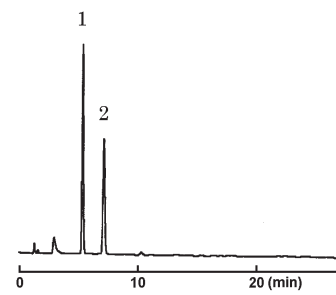

NACALAI TESQUE, INC

AP-0625

● Zidovudine

COSMOSIL Application Data

Column: 5C₁₈-MS-II
Column size: 4.6mmI.D.-250mm
Mobile phase: Methanol/ H_2O = 20/80
Flow rate: 1.0 ml/min
Temperature: 30°C
Detection: UV265nm

Sample:
1; Thymine (0.08 μg)
2; 3'-Azido-3'-Deoxythymidine [Zidovudine] (2.0 μg)

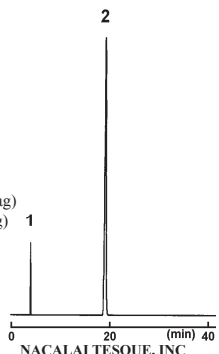

NACALAI TESQUE, INC

AP-1130

● Dipyridamole

COSMOSIL Application Data

Column: 5C₂-MS
Column size: 4.6mmI.D.-150mm
Mobile phase: Methanol/ 7.5mmol/l KH_2PO_4 = 80/20
Flow rate: 1.0 ml/min
Temperature: 40°C
Detection: UV280nm

Sample:
1; Dipyridamole (2.8 μg)
2; *p*-Terphenyl (1.2 μg)

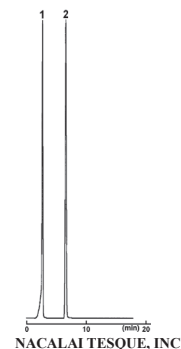

NACALAI TESQUE, INC

AP-0624

● Josamycin

COSMOSIL Application Data

Column: 5C₁₈-AR-II
 Column size: 4.6mm I.D.-150mm
 Mobile phase: Acetonitrile/ 0.8mol Sodium Perchlorate
 (pH2.5 with HCl) = 40/60
 Flow rate: 2.0 ml/min
 Temperature: 40°C
 Detection: UV231nm
 Sample: 1; Josamycin (10µg)

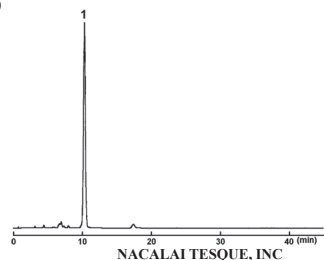

● Cilastatin Sodium Salt

COSMOSIL Application Data

Column: 5C₁₈-AR-II
 Column size: 4.6mm I.D.-250mm
 Mobile phase: A; 0.1% H₃PO₄
 B; Acetonitrile/ 0.1% H₃PO₄ = 30/70
 B conc. 15→30%(0→30min), 100%(30-40min)
 Flow rate: 2.0 ml/min
 Temperature: 50°C
 Detection: UV210nm
 Sample: 1; Cilastatin (1.0µg)

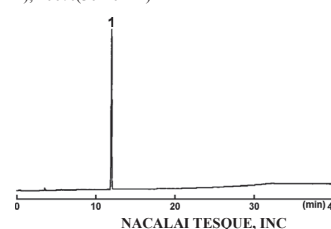

● Diltiazem Hydrochloride

COSMOSIL Application Data

Column: 5C₁₈-MS-II
 Column size: 4.6mm I.D.-150mm
 Mobile phase: Methanol/Acetonitrile/
 118mmol/l CH₃COONa,
 6.5mmol/l *d*-Camphorsulfonic Acid
 = 25/25/50(pH6.68)
 Flow rate: 1.0 ml/min
 Temperature: 50°C
 Detection: UV240nm
 Sample: 1; Diltiazem (3.0µg)
 2; Phenyl Benzoate (2.0µg)

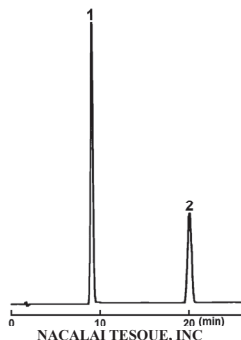

● Sulbactam Sodium

COSMOSIL Application Data

Column: 5C₁₈-MS-II
 Column size: 4.6mm I.D.-250mm
 Mobile phase: Acetonitrile/ 5mmol/l Tetra *n*-Butylammonium
 Hydroxide(pH4.0 with H₃PO₄) = 25/75
 Flow rate: 1.0 ml/min
 Temperature: 35°C
 Detection: UV220nm
 Sample: 1; Sulbactam (10µg)
 2; Ethyl *p*-Hydroxybenzoate (7.0µg)

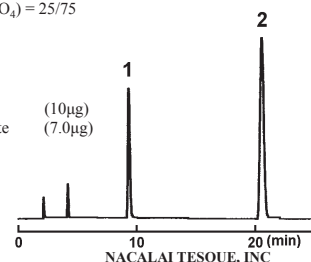

● Cetirizine Hydrochloride

COSMOSIL Application Data

Column: 5SL-II
 Column size: 4.6mm I.D.-250mm
 Mobile phase: Acetonitrile/ 40mmol/l Sulfuric Acid = 94/6
 Flow rate: 1.0 ml/min
 Temperature: 25°C
 Detection: UV230nm
 Sample: 1; Cetirizine (0.5µg)
 2; 4-Dimethylaminoantipyrine (0.9µg)

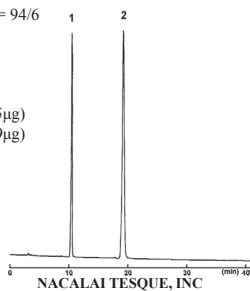

● Cetirizine Hydrochloride

COSMOSIL Application Data

Column: 5C₂-MS
 Column size: 4.6mm I.D.-250mm
 Mobile phase: Acetonitrile/ 1.7mmol/l Sodium *I*-Heptanesulfonate
 = 42/58 (pH3.0 with 0.5mol/l Sulfuric Acid)
 Flow rate: 1.0 ml/min
 Temperature: 25°C
 Detection: UV230nm
 Sample: 1; Cetirizine (2.0µg)
 2; Propyl *p*-Hydroxybenzoate (4.0µg)

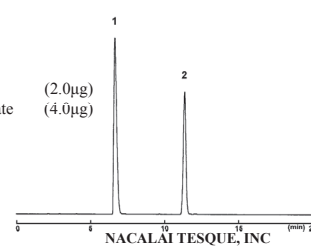

(1) Drugs

● Cefaclor

COSMOSIL Application Data

Column: 5C₁₈-PAQ
Column size: 4.6mmI.D.-150mm
Mobile phase: Acetonitrile/ 50mmol/l KH₂PO₄
(pH3.4 with H₃PO₄) =6/94
Flow rate: 2.0 ml/min
Temperature: 25°C
Detection: UV254nm

Sample: 1; Cefaclor (2.0µg)
2; *p*-Aminoacetophenone (2.9µg)

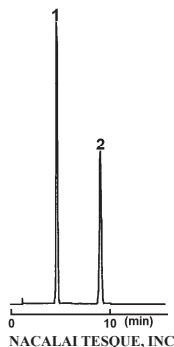

NACALAI TESQUE, INC

AP-0541

● Cefaclor

COSMOSIL Application Data

Column: 5C₁₈-MS-II
Column size: 4.6mmI.D.-250mm
Mobile phase: A; 50mmol/l NaH₂PO₄(pH4.0 with H₃PO₄)
B; Acetonitrile/Buffer A = 45/55
B conc. 5→25%(0-30min), 25→100%(30-45min),
100%(45-55min)

Flow rate: 1.0 ml/min
Temperature: 25°C
Detection: UV220nm

Sample: 1; Cefaclor (1.0µg)

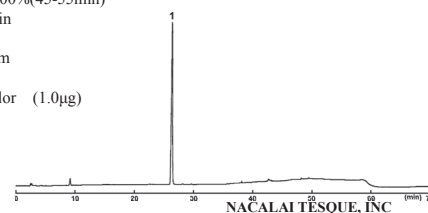

NACALAI TESQUE, INC

AP-0542

● Cefadroxil

COSMOSIL Application Data

Column: 5C₁₈-MS-II
Column size: 4.6mmI.D.-250mm
Mobile phase: Methanol/ 10mmol/ KH₂PO₄ = 60/340
Flow rate: 1.0 ml/min
Temperature: 40°C
Detection: UV262nm

Sample: 1; Cefadroxil (1.3µg)

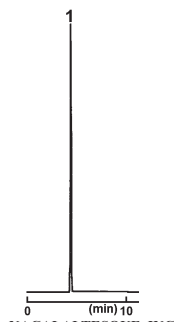

NACALAI TESQUE, INC

AP-0545

● Cephalothin Sodium Salt

COSMOSIL Application Data

Column: 5C₁₈-MS-II
Column size: 4.6mmI.D.-250mm
Mobile phase: Acetonitrile/Ethanol/ 158mmol/l CH₃COONa,
0.076%Acetic Acid(pH5.9 with NaOH)
=15/7/78

Flow rate: 1.0 ml/min
Temperature: 40°C
Detection: UV254nm

Sample: 1; Similar compound
2; Cephalothin Sodium
(0.25µg)

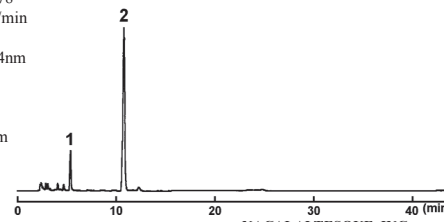

NACALAI TESQUE, INC

AP-0548

● Cefsulodin Sodium Salt

COSMOSIL Application Data

Column: 5C₁₈-PAQ
Column size: 4.6mmI.D.-150mm
Mobile phase: A; Acetonitrile/1%(NH₄)₂SO₄ = 3/97
B; Acetonitrile/1%(NH₄)₂SO₄ = 8/92
B conc. 0%(0-14min), 100%(14-30min)

Flow rate: 1.0 ml/min
Temperature: 25°C
Detection: UV254nm

Sample: 1; Isonicotinamide (0.2µg)
2; Cefsulodin (0.2µg)

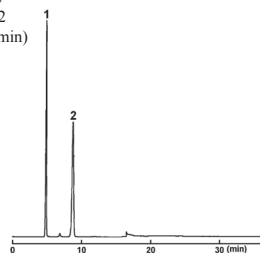

NACALAI TESQUE, INC

AP-0553

● Ceftazidime

COSMOSIL Application Data

Column: 5C₁₈-AR-II
Column size: 4.6mmI.D.-250mm
Mobile phase: Acetonitrile/ 50mmol/l (NH₄)₂PO₄
(pH3.5 with H₃PO₄) = 13/87

Flow rate: 1.0 ml/min
Temperature: 30°C
Detection: UV254nm

Sample: 1; Ceftazidime (2.5 µg)
2; Acetanilide (2.5 µg)

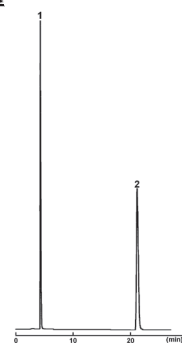

NACALAI TESQUE, INC

AP-0555

● Cefprozime

COSMOSIL Application Data

Column: 5C₁₈-MS-II
 Column size: 4.6mm I.D.-250mm
 Mobile phase: Acetonitrile/ 50mmol/l (NH₄)H₂PO₄
 = 30/70 (pH 7.0 with NH₃)
 Flow rate: 1.0 ml/min
 Temperature: 40°C
 Detection: UV254nm

Sample: 1; Cefprozime (0.5µg)
 2; Pyridine (0.5µg)

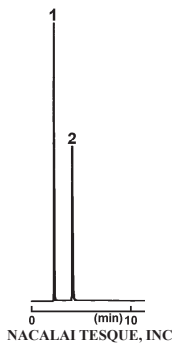

AP-0557

● Ceftriaxone Sodium

COSMOSIL Application Data

Column: 5C₁₈-MS-II
 Column size: 4.6mm I.D.-250mm
 Mobile phase: 18.1mmol/l tetra-*n*-heptylammonium
 bromide-Acetonitrile /
 4.1mmol/l Na₂HPO₄, 2.6mmol/l KH₂PO₄,
 0.88mmol/l Citric Acid, 1.8mmol/l NaOH
 = 45/55
 Flow rate: 1.0 ml/min
 Temperature: 25°C
 Detection: UV254nm

Sample: 1; Ceftriaxone (0.5µg)
 2; Terephthalic Acid Diethyl Ester (0.9µg)

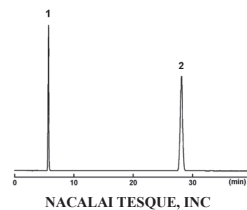

AP-0560

● Daunorubicin Hydrochloride

COSMOSIL Application Data

Column: 5C₁₈-MS-II
 Column size: 4.6mm I.D.-250mm
 Mobile phase: Acetonitrile/ H₂O = 38/62
 (pH 2.2 with H₃PO₄)
 Flow rate: 0.5 ml/min
 Temperature: 25°C
 Detection: UV254nm

Sample: 1; Daunorubicin (5.0µg)
 2; 2-Naphthalenesulfonic Acid (10µg)

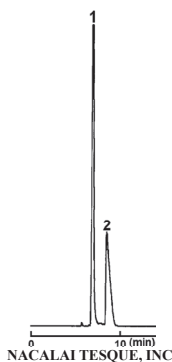

AP-0602

● Dantrolene Sodium

COSMOSIL Application Data

Column: 5SL-II
 Column size: 4.6mm I.D.-250mm
 Mobile phase: Hexane/Acetic Acid/Ethanol = 90/10/9
 Flow rate: 2.0 ml/min
 Temperature: 30°C
 Detection: UV300nm

Sample: 1; Theophylline (1.0µg)
 2; Dantrolene (0.06µg)

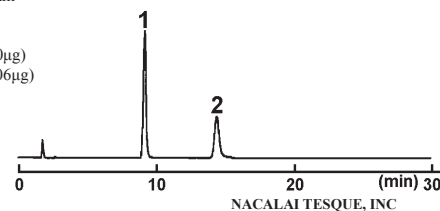

AP-0601

● Thiamine Hydrochloride

COSMOSIL Application Data

Column: 5C₁₈-AR-II
 Column size: 4.6mm I.D.-250mm
 Mobile phase: Methanol/Acetonitrile/ 5mmol/l Sodium
I-Octanesulfonate, 1% H₃PO₄ = 24/16/60
 Flow rate: 1.0 ml/min
 Temperature: 25°C
 Detection: UV254nm

Sample: 1; Vitamin B₁ [Thiamine] (4.0µg)
 2; Methyl Benzoate (20µg)

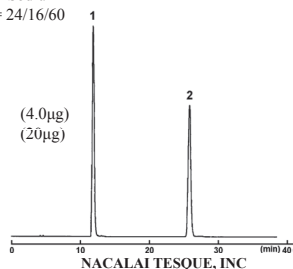

AP-0857

● Thiopental Sodiums

COSMOSIL Application Data

Column: 5C₁₈-MS-II
 Column size: 4.6mm I.D.-150mm
 Mobile phase: Acetonitrile/ 7mmol/l KH₂PO₄
 (pH 3.0 with H₃PO₄) = 30/70
 Flow rate: 1.5 ml/min
 Temperature: 40°C
 Detection: UV254nm

Sample: 1; Isopropyl *p*-Hydroxybenzoate (1.0µg)
 2; *n*-Propyl *p*-Hydroxybenzoate (1.0µg)
 3; Thiopental (Isomer)
 4; Thiopental (4.8µg)

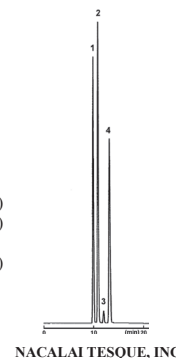

AP-0859

(1) Drugs

• Ticarcillin Sodium

COSMOSIL Application Data

Column: 5TMS-MS
Column size: 4.6mmI.D.-150mm
Mobile phase: Acetonitrile/ 5mmol/l Tetra-*n*-Butylammonium Bromide, 25mmol/l NaH₂PO₄(pH3.0 with H₃PO₄) / Acetic Acid = 225/1000/2.5
Flow rate: 1.0 ml/min
Temperature: 30°C
Detection: UV230nm

Sample: 1; *o*-Toluic Acid (2.5µg)
2; Ticarcillin (7.6µg)

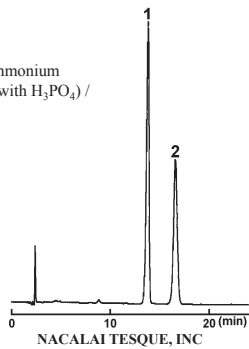

• Tipepidine Hibenzate

COSMOSIL Application Data

Column: 5C₁₈-MS-II
Column size: 4.6mmI.D.-150mm
Mobile phase: Tetrahydrofuran/ 1%Ammonium Acetate = 30/70
Flow rate: 1.0 ml/min
Temperature: 50°C
Detection: UV254nm

Sample: 1; Hibenzic Acid
2; Tipepidine
3; *n*-Propyl *p*-Hydroxybenzoate (0.6µg)

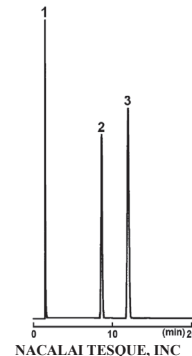

• Tipepidine Hibenzate

COSMOSIL Application Data

Column: 5C₁₈-MS-II
Column size: 4.6mmI.D.-150mm
Mobile phase: Methanol/ 0.2%Ammonium Acetate = 65/35
Flow rate: 1.0 ml/min
Temperature: 40°C
Detection: UV254nm

Sample: 1; Hibenzic Acid
2; Tipepidine
3; Xanthene (0.8µg)

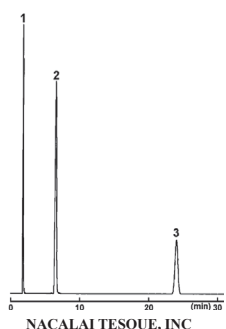

• Tipepidine Hibenzate

COSMOSIL Application Data

Column: 5C₁₈-AR-II
Column size: 4.6mmI.D.-150mm
Mobile phase: (Acetonitrile/ 2-Propanol = 2/1) / 0.1% Sodium Lauryl Sulfate, 0.2% H₃PO₄ = 50/50
Flow rate: 1.0 ml/min
Temperature: 40°C
Detection: UV254nm

Sample: 1; Hibenzic Acid
2; Tipepidine
3; Dibucaine (1.6µg)

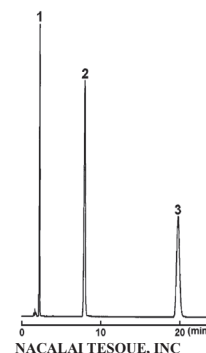

• Timolol Maleate

COSMOSIL Application Data

Column: 5PE-MS
Column size: 4.6mmI.D.-250mm
Mobile phase: Acetonitrile/Methanol/ 5mmol/l Sodium *I*-Hexanesulfonate, 0.3% Triethylamine, 0.4% Formic Acid(pH3.0 with Formic Acid) = 5/25/70
Flow rate: 1.0 ml/min
Temperature: 40°C
Detection: UV280nm

Sample: 1; Maleic Acid
2; Timolol (7.5µg)

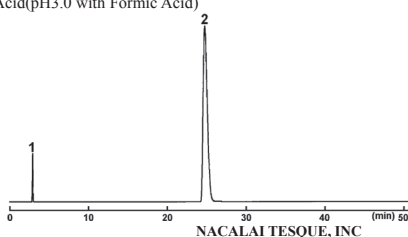

• Dexamethasone

COSMOSIL Application Data

Column: 5PE-MS
Column size: 4.6mmI.D.-250mm
Mobile phase: Acetonitrile/ 21mmol/l Ammonium Formate (pH3.6 with Formic Acid) = 33/67
Flow rate: 1.0 ml/min
Temperature: 30°C
Detection: UV254nm

Sample: 1; Dexamethasone (0.18µg)

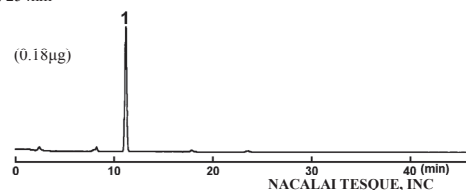

- Deferoxamine Mesilate

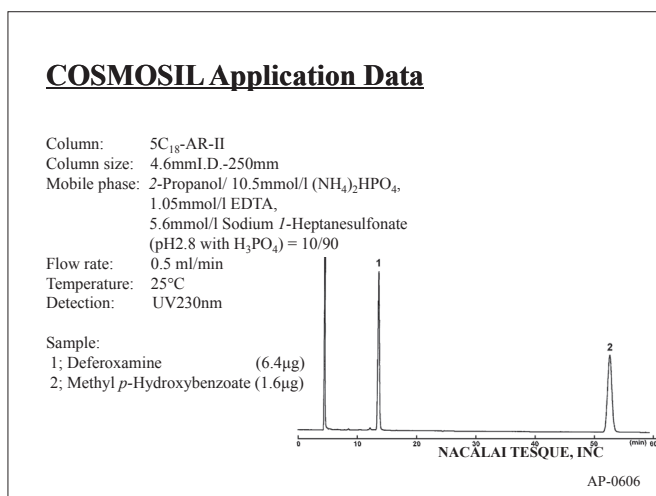

- Doxycycline Hydrochloride

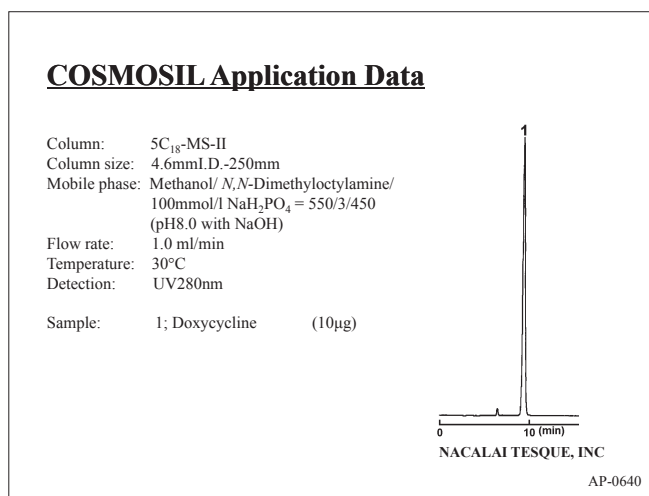

- Doxifluridine

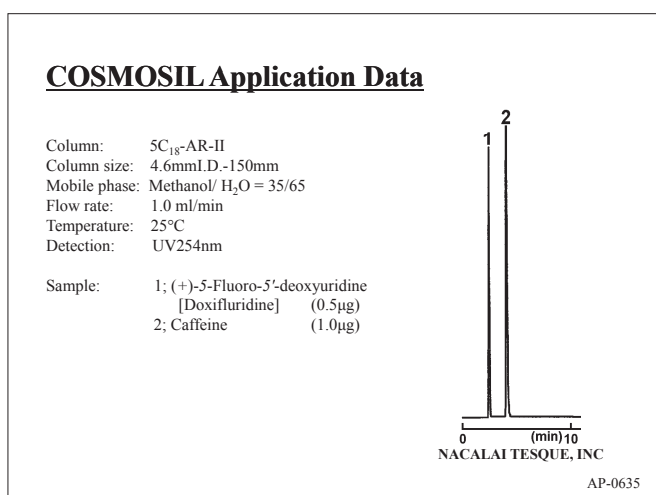

- Doxorubicin Hydrochloride

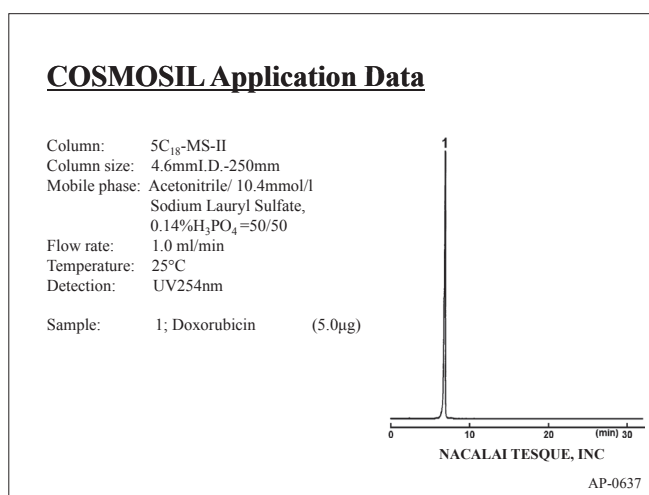

- Tocopherols

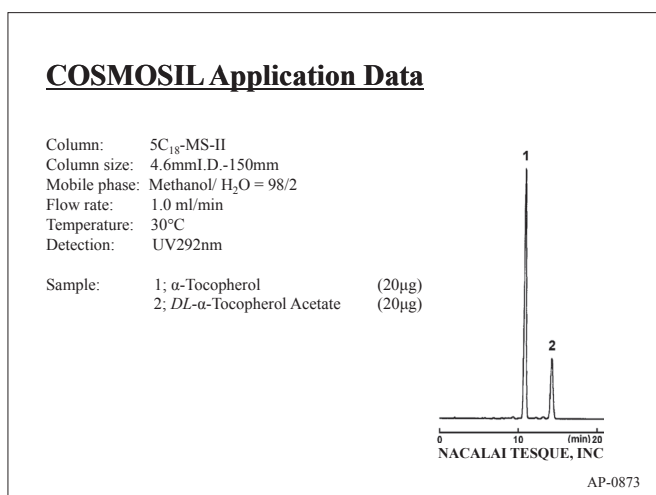

- Tocopherol Nicotinate

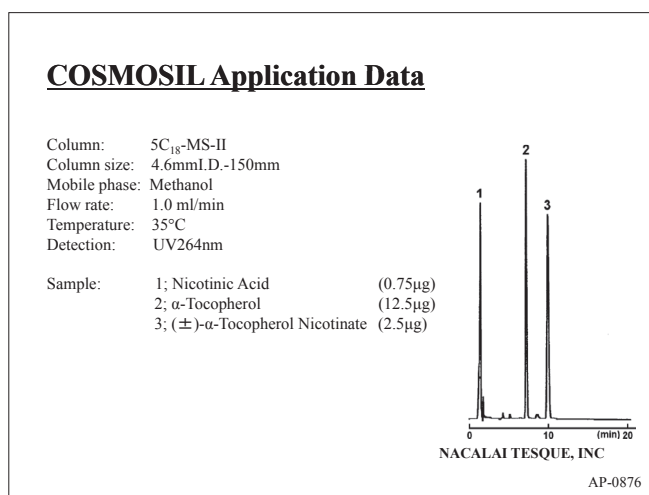

(1) Drugs

• Todalazine Hydrochloride

COSMOSIL Application Data

Column: 5C₁₈-MS-II
Column size: 4.6mmI.D.-250mm
Mobile phase: Methanol/ 5.4mmol/l Sodium
/ -Heptanesulfonate = 40/60
(pH3.5 with Acetic Acid)
Flow rate: 1.0 ml/min
Temperature: 25°C
Detection: UV240nm

Sample: 1; Phthalic Acid (0.4µg)
2; Todalazine (0.4µg)

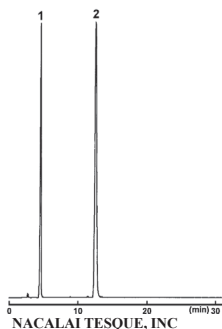

AP-0879

• Dopamine Hydrochloride

COSMOSIL Application Data

Column: 5C₁₈-MS-II
Column size: 4.6mmI.D.-250mm
Mobile phase: 200mmol/l Na₂HPO₄
(pH3.0 with Citric Acid)
Flow rate: 1.0 ml/min
Temperature: 25°C
Detection: UV280nm

Sample: 1; Uracil (0.5µg)
2; Dopamine (1.0µg)

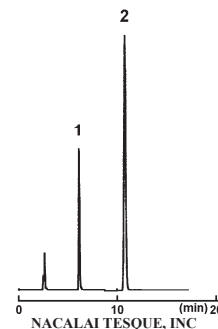

AP-0631

• Dobutamine Hydrochloride

COSMOSIL Application Data

Column: 5C₁₈-MS-II
Column size: 4.6mmI.D.-250mm
Mobile phase: Methanol/ 20mmol/l Tartrate buffer
(pH3.0) = 30/70
Flow rate: 1.0 ml/min
Temperature: 30°C
Detection: UV280nm

Sample: 1; Dobutamine (11µg)
2; Salicylamide (8.5µg)

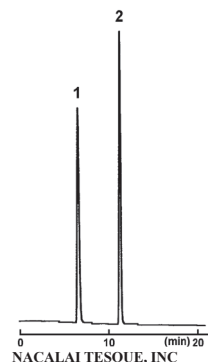

AP-0628

• Tolazamide

COSMOSIL Application Data

Column: 5SL-II
Column size: 4.6mmI.D.-250mm
Mobile phase: Hexane/ Water-saturated Hexane/
Tetrahydrofuran/ Ethanol/ Acetic Acid
= 475/ 475/ 20/ 15/ 9
Flow rate: 2.0 ml/min
Temperature: 30°C
Detection: UV254nm

Sample: 1; Tolbutamide (7.5µg)
2; Tolazamide (30µg)

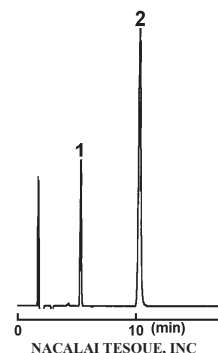

AP-0882

• Tranexamic Acid

COSMOSIL Application Data

Column: 5C₁₈-PAQ
Column size: 4.6mmI.D.-250mm
Mobile phase: Methanol/ 152mmol/l NaH₂PO₄,
8mmol/l Sodium Lauryl Sulfate,
0.83%Triethylamine(pH2.5 with H₃PO₄) = 40/60
Flow rate: 0.5 ml/min
Temperature: 35°C
Detection: UV220nm

Sample:
1; *trans*-4-(Aminomethyl)cyclohexanecarboxylic Acid
[Tranexamic Acid] (6.0µg)
2; 4-(Aminomethyl)benzoic Acid (0.06µg)

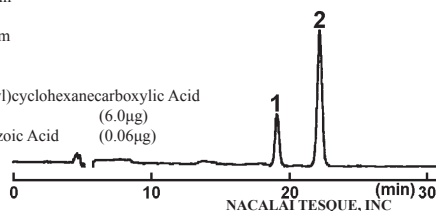

AP-0888

• Triamcinolone

COSMOSIL Application Data

Column: 5C₁₈-MS-II
Column size: 4.6mmI.D.-150mm
Mobile phase: Acetonitrile/ H₂O = 25/75
Flow rate: 0.5 ml/min
Temperature: 30°C
Detection: UV254nm

Sample: 1; Triamcinolone (1.0µg)
2; Methyl *p*-Hydroxybenzoate (0.4µg)

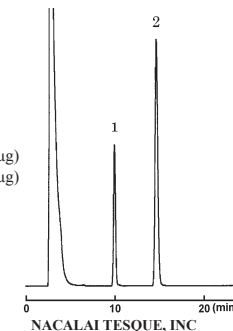

AP-0889

● Triamcinolone Acetonide

COSMOSIL Application Data

Column: 5C₁₈-MS-II
 Column size: 4.6mmI.D.-250mm
 Mobile phase: Acetonitrile/ H₂O = 35/65
 Flow rate: 1.0 ml/min
 Temperature: 25°C
 Detection: UV240nm

Sample: 1; Prednisolone (0.4µg)
 2; Triamcinolone Acetonide (0.8µg)



NACALAI TESQUE, INC

AP-0892

● Trimetazidine Hydrochloride

COSMOSIL Application Data

Column: 5C₁₈-MS-II
 Column size: 4.6mmI.D.-150mm
 Mobile phase: A; Methanol/ 14.2mmol/l Sodium *I*-Heptanesulfonate (pH 3.0 with 10% H₃PO₄) = 2/3
 B; Methanol
 B conc. 5%→25% 50min Linear gradient
 Flow rate: 1.0 ml/min
 Temperature: 40°C
 Detection: UV240nm

Sample: 1; *1*-(2,3,4-Trimethoxybenzyl)piperazine [Trimetazidine] (40µg)

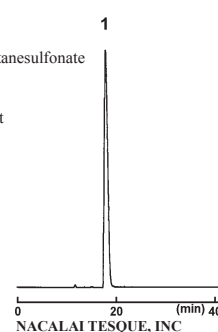

NACALAI TESQUE, INC

AP-1125

● Trimetazidine Hydrochloride

COSMOSIL Application Data

Column: 5C₁₈-MS-II
 Column size: 4.6mmI.D.-150mm
 Mobile phase: Methanol/ 50mmol/l KH₂PO₄ (pH3.0 with H₃PO₄) = 15/85
 Flow rate: 1.0 ml/min
 Temperature: 40°C
 Detection: UV230nm

Sample: 1; *1*-(2,3,4-Trimethoxybenzyl)piperazine [Trimetazidine] (0.15µg)
 2; *p*-Hydroxybenzoic Acid (0.18µg)

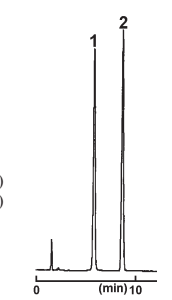

NACALAI TESQUE, INC

AP-0895

● Tolnaftate

COSMOSIL Application Data

Column: 5C₁₈-PAQ
 Column size: 4.6mmI.D.-150mm
 Mobile phase: Methanol/ H₂O = 70/30
 Flow rate: 1.0 ml/min
 Temperature: 25°C
 Detection: UV254nm

Sample: 1; Diphenyl Phthalate (18µg)
 2; Tolnaftate (4.0µg)

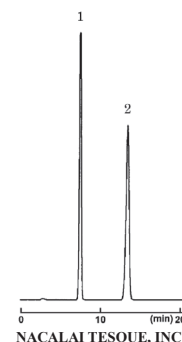

NACALAI TESQUE, INC

AP-0885

● Domperidone

COSMOSIL Application Data

Column: 5C₈-MS
 Column size: 4.6mmI.D.-250mm
 Mobile phase: Methanol/ 15.6mmol/l K₂HPO₄ (pH3.5 with 20mmol/l H₃PO₄) = 50/50
 Flow rate: 1.0 ml/min
 Temperature: 35°C
 Detection: UV287nm

Sample: 1; Domperidone (0.1µg)
 2; Ethyl *p*-hydroxybenzoate (0.2µg)

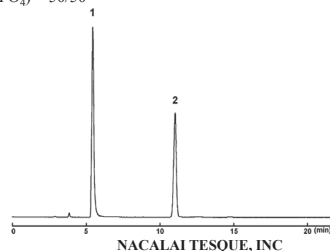

NACALAI TESQUE, INC

AP-1102

● Naphazoline and Chlorpheniramine

COSMOSIL Application Data

Column: 5C₁₈-AR-II
 Column size: 4.6mmI.D.-250mm
 Mobile phase: Acetonitrile/ 0.2% Sodium Lauryl Sulfate, 0.1% H₃PO₄ = 50/50
 Flow rate: 1.0 ml/min
 Temperature: 30°C
 Detection: UV254nm

Sample: 1; *o*-Ethoxybenzamide (5.1µg)
 2; Naphazoline Nitrate (2.2µg)
 3; Chlorpheniramine (4.1µg)

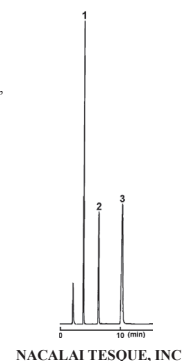

NACALAI TESQUE, INC

AP-0954

(1) Drugs

● Nabumetone

COSMOSIL Application Data

Column: 5C₁₈-AR-II
Column size: 4.6mmI.D.-150mm
Mobile phase: Acetonitrile/ Tetrahydrofuran/ 0.1% Acetic Acid = 28/12/60
Flow rate: 1.0 ml/min
Temperature: 40°C
Detection: UV254nm

Sample: 1; Nabumetone (10.0µg)

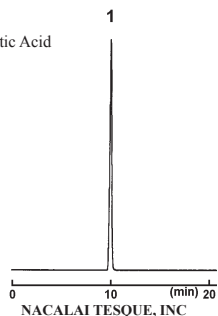

NACALAI TESQUE, INC

AP-1113

● Nalidixic Acid

COSMOSIL Application Data

Column: 5C₁₈-AR-II
Column size: 4.6mmI.D.-150mm
Mobile phase: Methanol/ 40mmol/l NaH₂PO₄ (pH2.8 with H₃PO₄) = 40/60
Flow rate: 1.0 ml/min
Temperature: 40°C
Detection: UV260nm

Sample: 1; Methyl *p*-Hydroxybenzoate (0.13 µg)
2; Nalidixic Acid (0.005 µg)

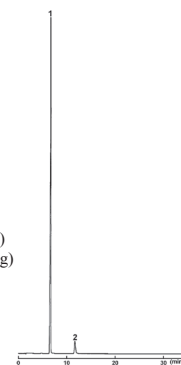

NACALAI TESQUE, INC

AP-0770

● Nicardipine Hydrochloride

COSMOSIL Application Data

Column: 5C₁₈-MS-II
Column size: 4.6mmI.D.-150mm
Mobile phase: Acetonitrile/ 0.05%Perchloric Acid = 40/60
Flow rate: 1.0 ml/min
Temperature: 30°C
Detection: UV254nm

Sample: 1; Nicardipine (0.4µg)
2; Nifedipine (0.4µg)

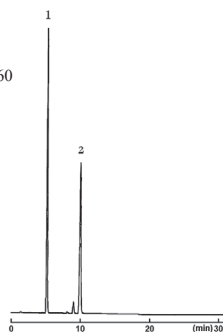

NACALAI TESQUE, INC

AP-0775

● Nicardipine Hydrochloride

COSMOSIL Application Data

Column: 5C₁₈-MS-II
Column size: 4.6mmI.D.-150mm
Mobile phase: Methanol/ 10mmol/l KH₂PO₄ = 68/32
Flow rate: 1.0 ml/min
Temperature: 40°C
Detection: UV254nm

Sample: 1; Nicardipine (0.4µg)
2; Di-*n*-butyl Phthalate (1.3µg)

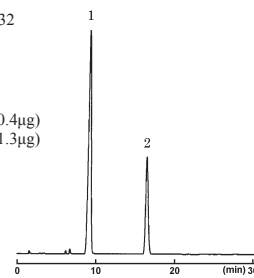

NACALAI TESQUE, INC

AP-0778

● Nicotinic Acid

COSMOSIL Application Data

Column: 5C₁₈-AR-II
Column size: 4.6mmI.D.-150mm
Mobile phase: 5mmol/l Sodium *I*-Octanesulfonate-Methanol/ 50mmol/l NaH₂PO₄(pH3.0) = 20/80
Flow rate: 0.5 ml/min
Temperature: 35°C
Detection: UV260nm

Sample: 1; Nicotinic Acid (1.0µg)
2; Caffeine (1.0µg)

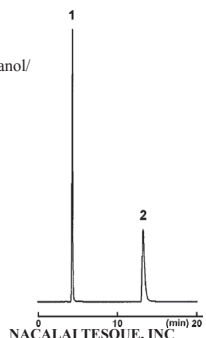

NACALAI TESQUE, INC

AP-0788

● Nicotinamide

COSMOSIL Application Data

Column: 5C₁₈-MS-II
Column size: 4.6mmI.D.-250mm
Mobile phase: Methanol/ 5mmol/l Sodium *I*-Heptanesulfonate = 30/70
Flow rate: 0.5 ml/min
Temperature: 25°C
Detection: UV254nm

Sample: 1; Nicotinic Acid (4.0µg)
2; Nicotinamide (0.8µg)

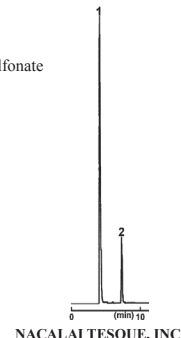

NACALAI TESQUE, INC

AP-0784

(1) Drugs

• Nicergolin

COSMOSIL Application Data

Column: 5C₁₈-MS-II
Column size: 4.6mm I.D.-250mm
Mobile phase: Methanol/Acetonitrile/ 50mmol/l KH₂PO₄ (pH 7.0 with Triethylamine) = 35/30/35
Flow rate: 1.0 ml/min
Temperature: 40°C
Detection: UV288nm

Sample: 1; Nicergoline (20µg)

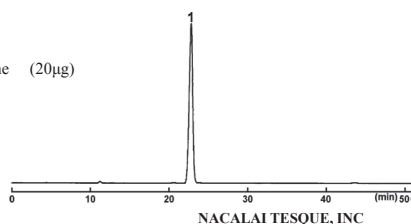

AP-0781

• Nitrendipine

COSMOSIL Application Data

Column: 5C₁₈-MS-II
Column size: 4.6mm I.D.-150mm
Mobile phase: Acetonitrile/Tetrahydrofuran/H₂O = 20/24/56
Flow rate: 0.5 ml/min
Temperature: 30°C
Detection: UV254nm

Sample: 1; *n*-Propyl *p*-Hydroxybenzoate (0.15µg)
2; Nitrendipine (0.50µg)

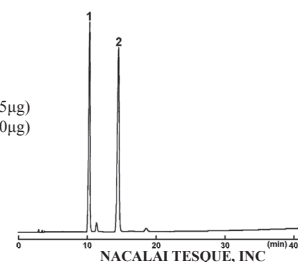

AP-0790

• Neostigmine Methylsulfate

COSMOSIL Application Data

Column: 5C₁₈-MS-II
Column size: 4.6mm I.D.-150mm
Mobile phase: Acetonitrile/ 20mmol/l NaH₂PO₄ (pH 3.0 with H₃PO₄), 5mmol/l Sodium *I*-Pentanesulfonate = 11/89
Flow rate: 1.0 ml/min
Temperature: 25°C
Detection: UV259nm

Sample: 1; Dimethylaminophenol (0.8µg)
2; Neostigmine Methyl Sulfate (5.0µg)

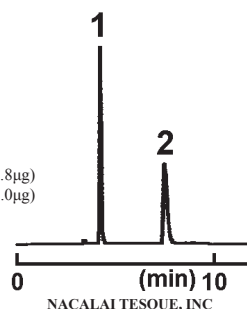

AP-0772

• Baclofen

COSMOSIL Application Data

Column: 5C₁₈-AR-II
Column size: 4.6mm I.D.-250mm
Mobile phase: Methanol/ 0.11% Acetic acid = 60/40
Flow rate: 0.5 ml/min
Temperature: 25°C
Detection: UV268nm

Sample: 1; Baclofen (5.0µg)
2; Methyl *p*-Hydroxybenzoate (0.063µg)

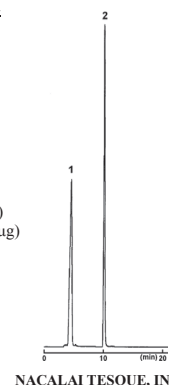

AP-0477

• Haloperidol

COSMOSIL Application Data

Column: 5C₁₈-AR-II
Column size: 4.6mm I.D.-150mm
Mobile phase: 3.5mmol/l Sodium Lauryl Sulfate-Methanol/ 10mmol/l *tri*-Sodium Citrate (pH 3.5 with HCl) = 75/25
Flow rate: 0.5 ml/min
Temperature: 40°C
Detection: UV220nm

Sample: 1; 4-(4-Chlorophenyl)-4-Hydroxypiperidine (0.20µg)
2; Haloperidol (0.20µg)
3; Biphenyl (0.16µg)

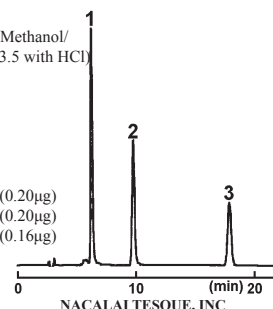

AP-0680

• Vancomycin Hydrochloride

COSMOSIL Application Data

Column: 5C₁₈-MS-II
Column size: 4.6mm I.D.-250mm
Mobile phase: A; Acetonitrile/Tetrahydrofuran/ 0.2% Triethylamine (pH 3.2 with H₃PO₄) = 7/1/92
B; Acetonitrile/Tetrahydrofuran/ 0.2% Triethylamine (pH 3.2 with H₃PO₄) = 29/1/70
B conc. 0%(0-12min), 0→100%(12→20min), 100%(20-22min)

Flow rate: 1.5 ml/min
Temperature: 25°C
Detection: UV280nm

Sample: 1; Similar compound 1
2; Vancomycin (5.0µg)
3; Similar compound 2

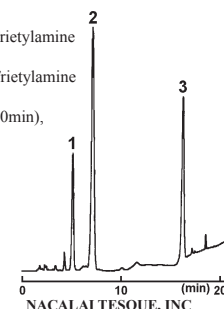

AP-0901

(1) Drugs

● Bisoprolol Fumarate

COSMOSIL Application Data

Column: 5C₈-MS
Column size: 4.6mm I.D.-150mm
Mobile phase: Acetonitrile/30mmol/l KH₂PO₄
(pH 2.5 with H₃PO₄) = 20/80
Flow rate: 1.0 ml/min
Temperature: 40°C
Detection: UV225nm

Sample: 1; Fumaric Acid
2; Bisoprolol

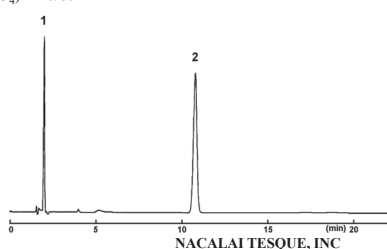

NACALAI TESQUE, INC
AP-1090

● Hydrochlorothiazide

COSMOSIL Application Data

Column: 5C₁₈-AR-II
Column size: 4.6mm I.D.-250mm
Mobile phase: Acetonitrile/100mmol/l NaH₂PO₄
(pH 3.0 with H₃PO₄) = 20/80
Flow rate: 1.0 ml/min
Temperature: 25°C
Detection: UV254nm

Sample: 1; 4-Amino-6-chloro-1,3-benzenedisulfonamide (1.0µg)
2; Hydrochlorothiazide (3.0µg)
3; *p*-Aminoacetophenone (3.6µg)

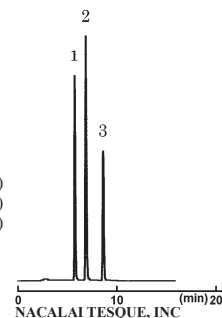

NACALAI TESQUE, INC
AP-0683

● Hydrocortisone

COSMOSIL Application Data

Column: SSL-II
Column size: 4.6mm I.D.-250mm
Mobile phase: Chloroform/Methanol/Acetic Acid
= 1000/20/1
Flow rate: 2.0 ml/min
Temperature: 30°C
Detection: UV254nm

Sample: 1; Prednisone (0.9µg)
2; Hydrocortisone (2.0µg)

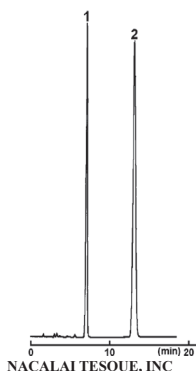

NACALAI TESQUE, INC
AP-0685

● Hydrocortisone Succinate

COSMOSIL Application Data

Column: 5C₁₈-MS-II
Column size: 4.6mm I.D.-250mm
Mobile phase: Acetonitrile/40mmol/l CH₃COONa
(pH 4.0 with Acetic Acid) = 40/60
Flow rate: 1.0 ml/min
Temperature: 25°C
Detection: UV254nm

Sample: 1; Hydrocortisone (0.4µg)
2; Hydrocortisone 2/-Hemisuccinate (1.0µg)
3; Butyl *p*-Hydroxybenzoate (0.3µg)

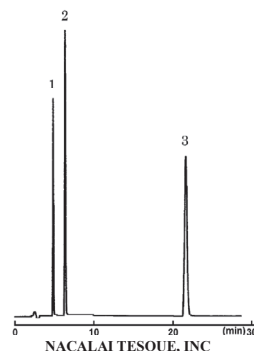

NACALAI TESQUE, INC
AP-0689

● Hydrocortisone Acetate

COSMOSIL Application Data

Column: 5C₁₈-MS-II
Column size: 4.6mm I.D.-250mm
Mobile phase: Acetonitrile/ H₂O = 45/55
Flow rate: 1.0 ml/min
Temperature: 30°C
Detection: UV254nm

Sample: 1; Hydrocortisone (2.0µg)
2; Hydrocortisone Acetate (4.0µg)
3; Benzyl *p*-Hydroxybenzoate (2.0µg)

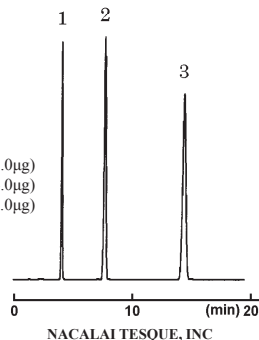

NACALAI TESQUE, INC
AP-0686

● Hypromellose Phthalate (impurity)

COSMOSIL Application Data

Column: 5C₁₈-AR-II
Column size: 4.6mm I.D.-250mm
Mobile phase: Acetonitrile/100mmol/l Cyanoacetic Acid
= 15/85
Flow rate: 2.0 ml/min
Temperature: 30°C
Detection: UV235nm

Sample: 1; Phthalic Acid (0.5µg)

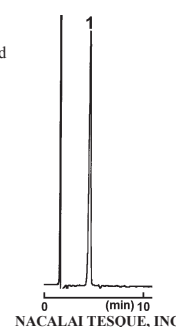

NACALAI TESQUE, INC
AP-0933

(1) Drugs

● Piperacillin Sodium

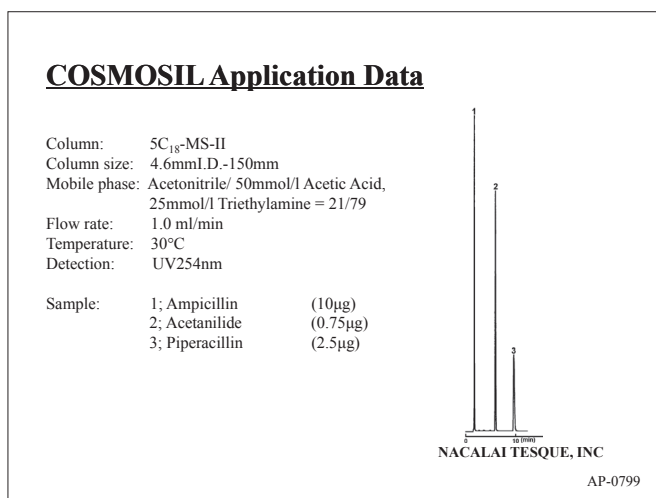

● Piperacillin Sodium

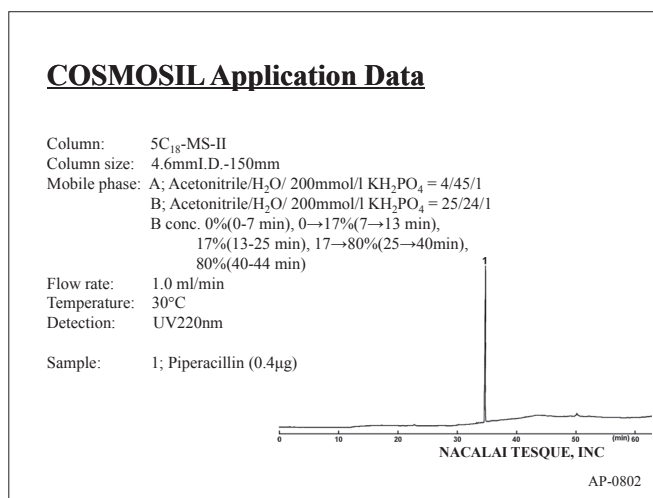

● Pimaricin

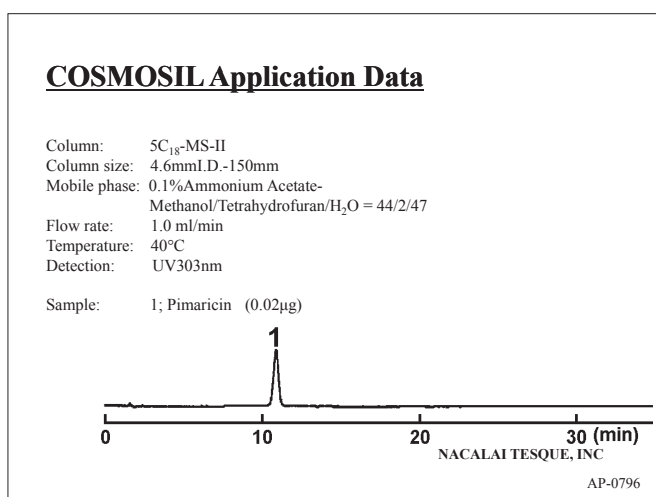

● Vincristine Sulfate

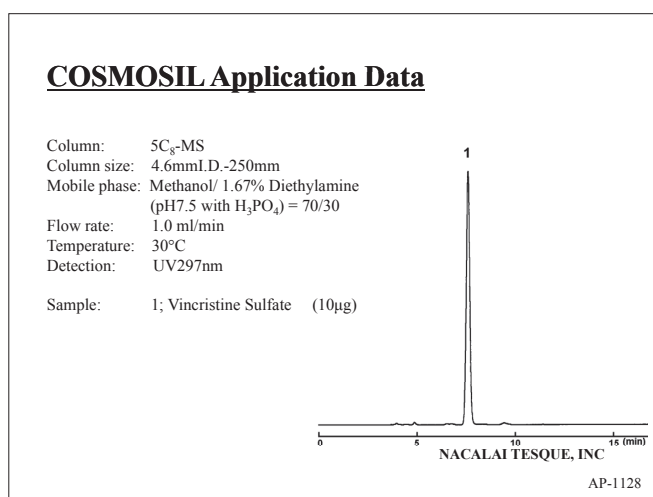

● Famotidine

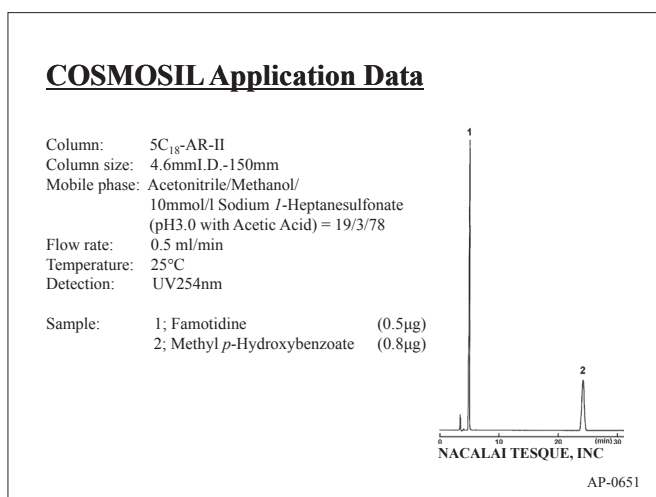

● Scopolamine Butyl Bromide

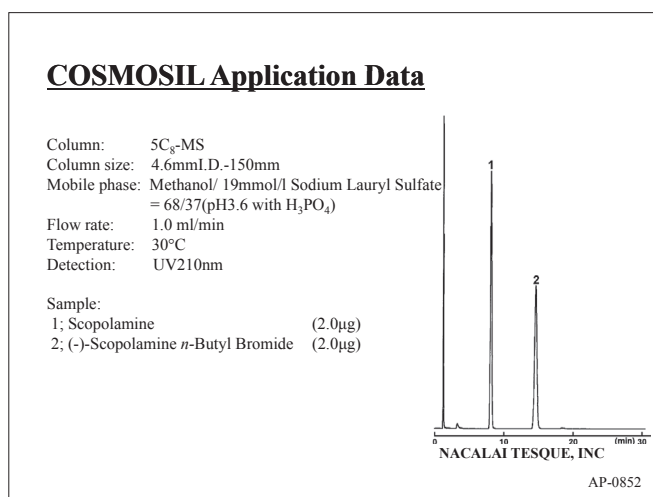

(1) Drugs

• Bufexamac

COSMOSIL Application Data

Column: 5C₁₈-AR-II
Column size: 4.6mmI.D.-150mm
Mobile phase: Methanol/Acetonitrile/
13.6mmol/l Sodium *l*-Octane Sulfonate
0.94%Acetic Acid, 1.9mmol/l EDTA
= 24/24/52
Flow rate: 1.0 ml/min
Temperature: 30°C
Detection: UV275nm

Sample: 1; Bufexamac (2 μg)
2; 4,5-Diphenylimidazole (0.16 μg)

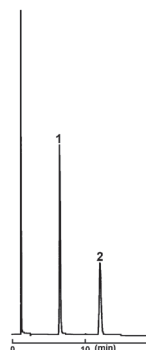

NACALAI TESQUE, INC

AP-0522

• Pravastatin

COSMOSIL Application Data

Column: 5C₁₈-MS-II
Column size: 4.6mmI.D.-150mm
Mobile phase: Methanol/H₂O/Acetic Acid/Triethylamine
= 500/500/1/1
Flow rate: 1.0 ml/min
Temperature: 25°C
Detection: UV238nm

Sample: 1; Ethyl *p*-Hydroxybenzoate (0.7 μg)
2; Pravastatin (1.6 μg)

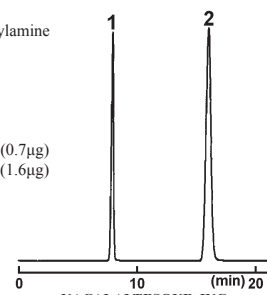

NACALAI TESQUE, INC

AP-0811

• Flavin Adenine Dinucleotide Sodium

COSMOSIL Application Data

Column: 5C₁₈-MS-II
Column size: 4.6mmI.D.-250mm
Mobile phase: Methanol/ 0.2%K₂HPO₄ = 20/80
Flow rate: 1.0 ml/min
Temperature: 35°C
Detection: UV260nm

Sample: 1; Adenosine (1.0 μg)
2; Flavin Adenine Dinucleotide [FAD] (4.0 μg)
3; Flavin Mononucleotide [FMN] (4.0 μg)
4; Vitamin B₂ [Riboflavin] (1.0 μg)

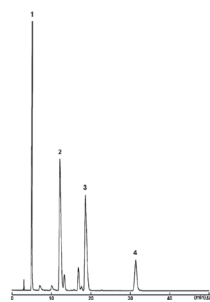

NACALAI TESQUE, INC

AP-0653

• Fluoxymesterone

COSMOSIL Application Data

Column: 5SL-II
Column size: 4.6mmI.D.-250mm
Mobile phase: *n*-Butyl Chloride/Water-saturated *n*-Butyl
Chloride/Tetrahydrofuran/Methanol/
Acetic Acid = 95/95/14/7/6
Flow rate: 1.0 ml/min
Temperature: 30°C
Detection: UV254nm

Sample: 1; Fluoxymesterone (2.7 μg)
2; 6α-Methylprednisolone (2.0 μg)

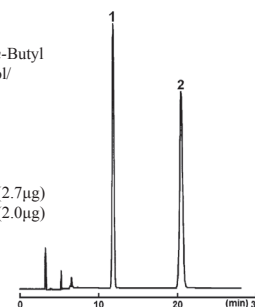

NACALAI TESQUE, INC

AP-0669

• Fluocinonide

COSMOSIL Application Data

Column: 5C₁₈-MS-II
Column size: 4.6mmI.D.-250mm
Mobile phase: Acetonitrile/ H₂O = 50/50
Flow rate: 1.0 ml/min
Temperature: 40°C
Detection: UV254nm

Sample: 1; Fluocinolone Acetonide 21-Acetate (4.0 μg)
2; Propyl Benzoate (12.6 μg)

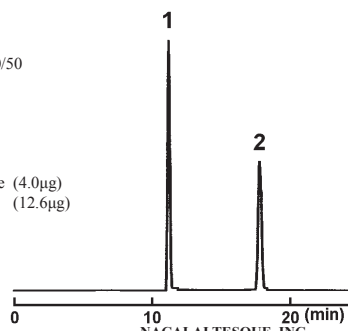

NACALAI TESQUE, INC

AP-0663

• Fluocinolone Acetonide

COSMOSIL Application Data

Column: 5C₁₈-AR-II
Column size: 4.6mmI.D.-250mm
Mobile phase: Acetonitrile/ H₂O = 30/70
Flow rate: 1.0 ml/min
Temperature: 40°C
Detection: UV254nm

Sample: 1; Ethyl *p*-Hydroxybenzoate (0.6 μg)
2; Isopropyl *p*-Hydroxybenzoate (1.0 μg)
3; Fluocinolone Acetonide (4.0 μg)
4; *n*-Propyl *p*-Hydroxybenzoate (1.0 μg)

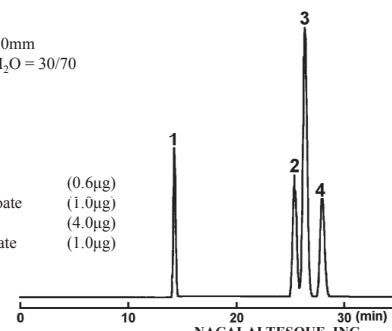

NACALAI TESQUE, INC

AP-0660

● Fluocinolone Acetonide

COSMOSIL Application Data

Column: 5SL-II
Column size: 4.6mmI.D.-250mm
Mobile phase: Water-saturated Chloroform/Methanol/
Acetic Acid = 200/3/2
Flow rate: 1.0 ml/min
Temperature: 30°C
Detection: UV254nm

Sample: 1; Triamcinolone Acetonide (3.0µg)
2; Fluocinolone Acetonide (3.0µg)

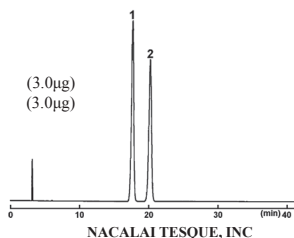

AP-0662

● Fluorometholone

COSMOSIL Application Data

Column: 5C₁₈-MS-II
Column size: 4.6mmI.D.-250mm
Mobile phase: Methanol/ H₂O = 70/30
Flow rate: 1.0 ml/min
Temperature: 35°C
Detection: UV254nm

Sample: 1; Fluorometholone (0.20µg)
2; Butyl *p*-Hydroxybenzoate (0.16µg)

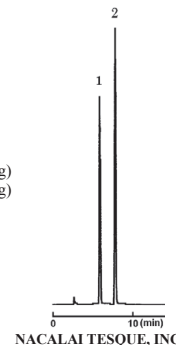

AP-0666

● Flurbiprofen

COSMOSIL Application Data

Column: 5C₁₈-AR-II
Column size: 4.6mmI.D.-150mm
Mobile phase: Acetonitrile/ 7.7% H₃PO₄ = 35/65
Flow rate: 1.0 ml/min
Temperature: 30°C
Detection: UV254nm

Sample: 1; Flurbiprofen (0.2µg)

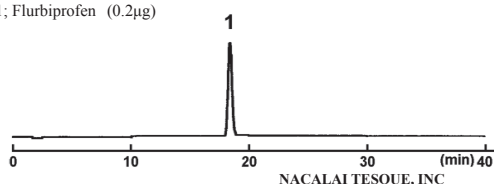

AP-0671

● Prednisolone Acetate

COSMOSIL Application Data

Column: 5C₁₈-MS-II
Column size: 4.6mmI.D.-150mm
Mobile phase: Acetonitrile/ H₂O = 40/60
Flow rate: 1.0 ml/min
Temperature: 25°C
Detection: UV254nm

Sample: 1; Prednisolone (1.5µg)
2; Prednisolone 21-Acetate (1.0µg)
3; Cortisone-21-Acetate (1.5µg)
4; Butyl *p*-Hydroxybenzoate (0.5µg)

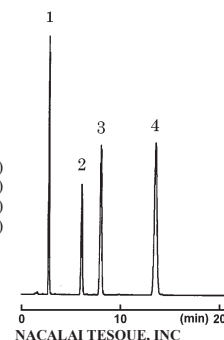

AP-0814

● Procaine Hydrochloride

COSMOSIL Application Data

Column: 5C₁₈-MS-II
Column size: 4.6mmI.D.-150mm
Mobile phase: Methanol/ 0.1% Sodium *I*-Pentanesulfonate,
50mmol/l KH₂PO₄(pH3.0 with H₃PO₄)
= 20/80
Flow rate: 0.5 ml/min
Temperature: 40°C
Detection: UV254nm

Sample: 1; Procaine (1.25µg)
2; Caffeine (1.25µg)

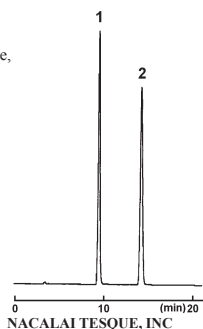

AP-0817

● Procaterol Hydrochloride

COSMOSIL Application Data

Column: 5C₁₈-AR-II
Column size: 4.6mmI.D.-250mm
Mobile phase: Methanol/ 5mmol/l Sodium *I*-Pentanesulfonate/
Acetic Acid = 23/76/1
Flow rate: 1.0 ml/min
Temperature: 40°C
Detection: UV254nm

Sample: 1; Procaterol (0.06µg)

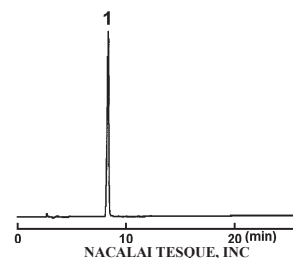

AP-0821

(1) Drugs

● Propranolol Hydrochloride

COSMOSIL Application Data

Column: 5C₁₈-MS-II
Column size: 4.6mmI.D.-250mm
Mobile phase: Acetonitrile/ 12mmol/l Sodium Lauryl Sulfate,
0.7mmol/l Tetra-*n*-butylammonium Phosphate/
Sulfuric Acid = 550/450/1(pH3.3 with NaOH)
Flow rate: 1.0 ml/min
Temperature: 25°C
Detection: UV292nm

Sample: 1; Propranolol (0.08µg)

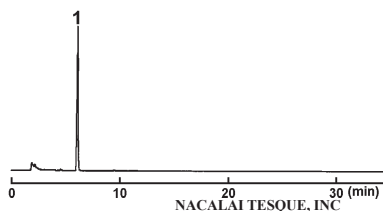

NACALAI TESQUE, INC
AP-0823

● Flopropione

COSMOSIL Application Data

Column: 5C₁₈-AR-II
Column size: 4.6mmI.D.-150mm
Mobile phase: Acetonitrile/ 1.2% H_3PO_4 = 57/43
Flow rate: 1.0 ml/min
Temperature: 35°C
Detection: UV267nm

Sample: 1; 2',4',6'-Trihydroxypropiphenone
[Flopropione] (0.40µg)
2; Ethyl 4-Hydroxybenzoate (0.26µg)

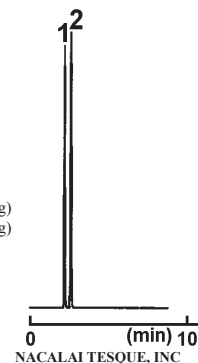

NACALAI TESQUE, INC
AP-0657

● Bromhexine Hydrochloride

COSMOSIL Application Data

Column: 5C₁₈-MS-II
Column size: 4.6mmI.D.-150mm
Mobile phase: Acetonitrile/ 7.3mmol/l KH₂PO₄
(pH7.0 with NaOH) = 80/20
Flow rate: 2.0 ml/min
Temperature: 40°C
Detection: UV245nm

Sample: 1; Bamethane (25µg)
2; Bromhexine (1.25µg)

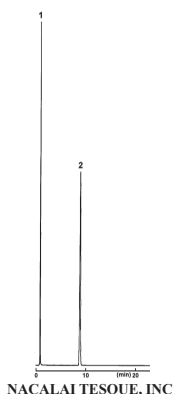

NACALAI TESQUE, INC
AP-0518

● Beclomethasone Dipropionate

COSMOSIL Application Data

Column: 5C₁₈-MS-II
Column size: 4.6mmI.D.-150mm
Mobile phase: Acetonitrile/ H₂O = 60/40
Flow rate: 1.0 ml/min
Temperature: 25°C
Detection: UV254nm

Sample: 1; Beclomethasone Dipropionate (1.6µg)
2; Testosterone Propionate (0.8µg)



NACALAI TESQUE, INC
AP-0479

● Bezafibrate

COSMOSIL Application Data

Column: 5C₁₈-AR-II
Column size: 4.6mmI.D.-150mm
Mobile phase: Methanol/ 0.1%Acetic Acid = 9/4
Flow rate: 1.0 ml/min
Temperature: 30°C
Detection: UV230nm

Sample: 1; 4-Chlorobenzoic Acid (0.55µg)
2; Bezafibrate (1.05µg)

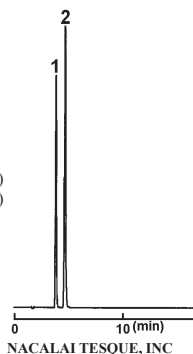

NACALAI TESQUE, INC
AP-0510

● Bezafibrate

COSMOSIL Application Data

Column: 5C₁₈-AR-II
Column size: 4.6mmI.D.-150mm
Mobile phase: Methanol/ 0.1%Acetic Acid = 9/4
Flow rate: 1.0 ml/min
Temperature: 30°C
Detection: UV230nm

Sample: 1; *p*-Nitrophenol (0.32µg)
2; Bezafibrate (0.44µg)

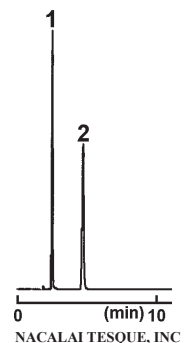

NACALAI TESQUE, INC
AP-0513

(1) Drugs

● Betahistine Mesilate

COSMOSIL Application Data

Column: 5C₁₈-MS-II
Column size: 4.6mmI.D.-150mm
Mobile phase: 8mmol/l Sodium Lauryl Sulfate-Acetonitrile/ 2%Acetic Acid, 0.5%Diethylamine = 37/63
Flow rate: 1.0 ml/min
Temperature: 35°C
Detection: UV261nm

Sample: 1; 2-Vinylpyridine (0.16µg)
2; 2-(2-Methylaminoethyl)pyridine [Betahistine] (0.16µg)

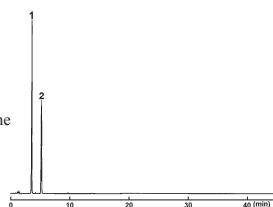

NACALAI TESQUE, INC

AP-0488

● Betamethasone

COSMOSIL Application Data

Column: 5C₁₈-MS-II
Column size: 4.6mmI.D.-150mm
Mobile phase: Methanol/ H₂O = 60/40
Flow rate: 1.0 ml/min
Temperature: 25°C
Detection: UV241nm

Sample: 1; Betamethasone (0.06µg)

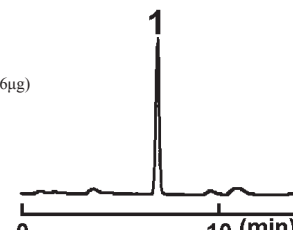

NACALAI TESQUE, INC

AP-0497

● Betamethasone Sodium Phosphate

COSMOSIL Application Data

Column: 5C₁₈-MS-II
Column size: 4.6mmI.D.-250mm
Mobile phase: Methanol / 5mmol/l Tetra-*n*-butylammonium Bromide 8.9mmol/l Na₂HPO₄, 50.7mmol/l KH₂PO₄ = 60/40
Flow rate: 1.0 ml/min
Temperature: 25°C
Detection: UV254nm

Sample: 1; Betamethasone 21-Phosphate (1.0µg)
2; Butyl *p*-Hydroxybenzoate (0.2µg)

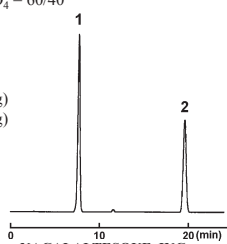

NACALAI TESQUE, INC

AP-0494

● Betamethasone Valerate

COSMOSIL Application Data

Column: 5C₁₈-MS-II
Column size: 4.6mmI.D.-150mm
Mobile phase: Methanol/ H₂O = 65/35
Flow rate: 1.0 ml/min
Temperature: 30°C
Detection: UV254nm

Sample: 1; Betamethasone 17-Valerate (1.5µg)
2; Beclomethasone Dipropionate (1.5µg)

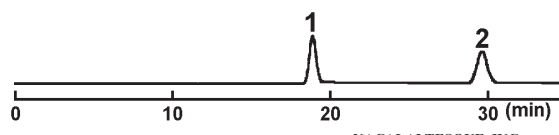

NACALAI TESQUE, INC

AP-0503

● Benzylpenicillin Potassium

COSMOSIL Application Data

Column: 5C₁₈-MS-II
Column size: 4.6mmI.D.-250mm
Mobile phase: Acetonitrile/ 50mmol/l (NH₄)₂HPO₄ = 24/76 (pH8 with H₃PO₄)
Flow rate: 1.0 ml/min
Temperature: 25°C
Detection: UV254nm

Sample: 1; Penicillin G (4.0µg)
2; Methyl *p*-Hydroxybenzoate (0.06µg)

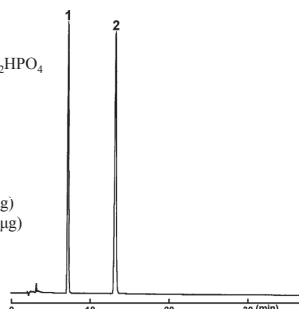

NACALAI TESQUE, INC

AP-0482

● Calcium Folate

COSMOSIL Application Data

Column: 5C₁₈-MS-II
Column size: 4.6mmI.D.-250mm
Mobile phase: [H₂O/Acetonitrile/Methanol/ 40%Tetra-*n*-butylammonium Hydroxide = 760/200/8.6/9.4 (pH7.5 with NaH₂PO₄)] →1000(with H₂O)
Flow rate: 0.5 ml/min
Temperature: 30°C
Detection: UV254nm

Sample: 1; Calcium Folate (2.8µg)
2; Folic Acid (0.8µg)

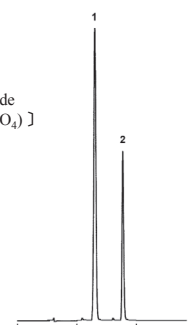

NACALAI TESQUE, INC

AP-0524

(1) Drugs

● Calcium Folate

COSMOSIL Application Data

Column: 5C₁₈-MS-II
Column size: 4.6mmI.D.-150mm
Mobile phase: Methanol/ 8mmol/l Na₂HPO₄/ Tetrabutylammonium Hydroxide = 110/385/4 (pH 7.5 with H₃PO₄)
Flow rate: 1.0 ml/min
Temperature: 45°C
Detection: UV254nm

Sample: 1; Calcium Folate (2.0µg)
2; Folic Acid (2.0µg)

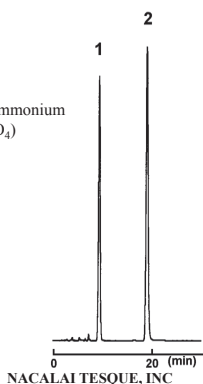

NACALAI TESQUE, INC
AP-1093

● Mitomycin C

COSMOSIL Application Data

Column: SPE-MS
Column size: 4.6mmI.D.-250mm
Mobile phase: Methanol/ 20mmol/l Ammonium Acetate, 0.025% Acetic Acid = 40/60
Flow rate: 1.0 ml/min
Temperature: 25°C
Detection: UV365nm

Sample: 1; Mitomycin C (5.0µg)
2; Ethyl Vanillin [3-Ethoxy-4-Hydroxybenzaldehyde] (75µg)

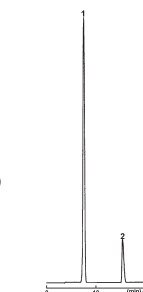

NACALAI TESQUE, INC
AP-0768

● Mizoribine

COSMOSIL Application Data

Column: 5C₁₈-PAQ
Column size: 4.6mmI.D.-250mm
Mobile phase: 0.067% H₃PO₄ aq.
Flow rate: 1.0 ml/min
Temperature: 30°C
Detection: UV279nm

Sample: 1; Mizoribine (1.0µg)

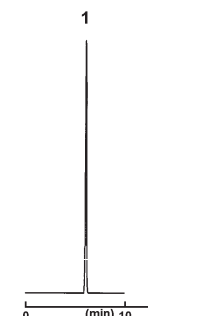

NACALAI TESQUE, INC
AP-1108

● Minocycline Hydrochloride

COSMOSIL Application Data

Column: 5C₇-MS
Column size: 4.6mmI.D.-150mm
Mobile phase: 2.8% Ammonium Oxalate/N,N-dimethylformamide/ 100mmol/l EDTA = 11/5/4 (pH6.2 with Tetrabutylammonium Hydroxide)
Flow rate: 1.0 ml/min
Temperature: 30°C
Detection: UV280nm

Sample: 1; 4-*epi*-Minocycline
2; Minocycline

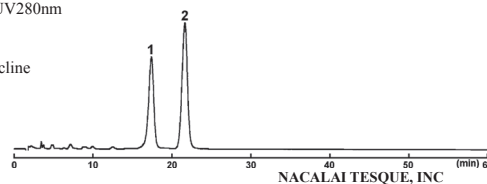

NACALAI TESQUE, INC
AP-0767

● Mexiletine Hydrochloride

COSMOSIL Application Data

Column: 5C₈-MS
Column size: 4.6mmI.D.-150mm
Mobile phase: Acetonitrile/ 14.4mmol/l Sodium Lauryl Sulfate, 25mmol/l NaH₂PO₄ = 21/30
Flow rate: 2.0 ml/min
Temperature: 30°C
Detection: UV210nm

Sample: 1; β-Phenylethylamine (0.6µg)
2; 1-(2,6-Dimethylphenoxy)-2-Propanamine [Mexiletine] (1.0µg)

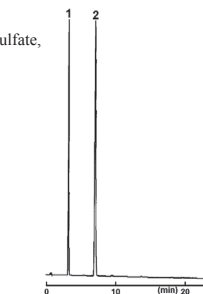

NACALAI TESQUE, INC
AP-0766

● Mecobalamin

COSMOSIL Application Data

Column: 5C₁₈-PAQ
Column size: 4.6mmI.D.-250mm
Mobile phase: 100mmol/l Sodium 1-Hexanesulfonate, Acetonitrile/ 20mmol/l Phosphate buffer(pH3.5) = 20/80
Flow rate: 0.5 ml/min
Temperature: 40°C
Detection: UV266nm

Sample: 1; Vitamin B₁₂ [Cyanocobalamin] (0.5µg)
2; Hydroxocobalamin Acetate (0.5µg)
3; Mecobalamin (1.0µg)

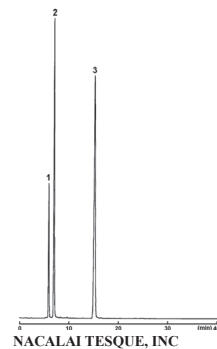

NACALAI TESQUE, INC
AP-0738

● Meticrane

COSMOSIL Application Data

Column: 5C₁₈-MS-II
 Column size: 4.6mmI.D.-150mm
 Mobile phase: Acetonitrile/ H₂O = 15/85
 Flow rate: 1.0 ml/min
 Temperature: 40°C
 Detection: UV230nm

Sample: 1; Caffeine (0.2µg)
 2; Meticrane (0.2µg)

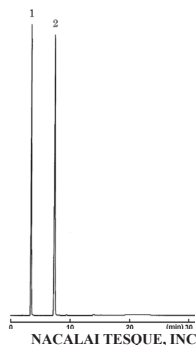

AP-0754

● Meticrane

COSMOSIL Application Data

Column: 5C₁₈-MS-II
 Column size: 4.6mmI.D.-150mm
 Mobile phase: Acetonitrile/ H₂O = 50/50
 Flow rate: 1.0 ml/min
 Temperature: 40°C
 Detection: UV230nm

Sample: 1; Meticrane (0.4µg)
 2; Methyl *p*-Hydroxybenzoate (0.4µg)

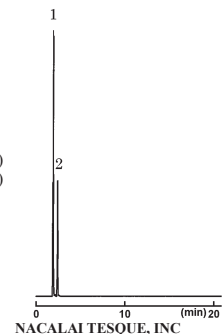

AP-0757

● Methotrexate

COSMOSIL Application Data

Column: 5C₁₈-MS-II
 Column size: 4.6mmI.D.-250mm
 Mobile phase: Acetonitrile/ 200mmol/l Na₂HPO₄
 (pH6.0 with 100mmol/l Citric Acid) = 10/90
 Flow rate: 1.0 ml/min
 Temperature: 30°C
 Detection: UV302nm

Sample: 1; Folic Acid (1.0µg)
 2; Methotrexate (1.0µg)

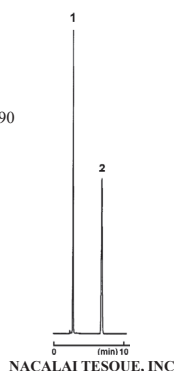

AP-0751

● Metformin Hydrochloride

COSMOSIL Application Data

Column: 5C₁₈-AR-II
 Column size: 4.6mmI.D.-150mm
 Mobile phase: Acetonitrile/ 4.5mmol/l Sodium Lauryl Sulfate,
 0.04% H₃PO₄ = 38/62
 Flow rate: 1.0 ml/min
 Temperature: 40°C
 Detection: UV235nm

Sample: 1; *1,1*-Dimethylbiguanide
 [Metformin] (0.50µg)
 2; Isobutyl *p*-Hydroxybenzoate (0.95µg)

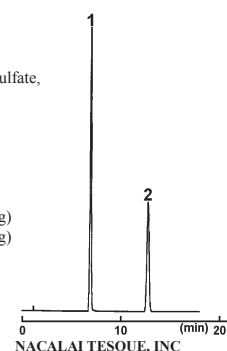

AP-0761

● Metronidazole

COSMOSIL Application Data

Column: 5C₁₈-MS-II
 Column size: 4.6mmI.D.-150mm
 Mobile phase: Methanol/ H₂O = 20/80
 Flow rate: 1.0 ml/min
 Temperature: 30°C
 Detection: UV320nm

Sample: 1; Metronidazole (0.24µg)



AP-0763

● Menatetrenone

COSMOSIL Application Data

Column: 5C₁₈-MS-II
 Column size: 4.6mmI.D.-150mm
 Mobile phase: Methanol
 Flow rate: 1.0 ml/min
 Temperature: 40°C
 Detection: UV270nm

Sample: 1; Menatetrenone (0.6µg)
 2; Vitamin K₁ (0.6µg)

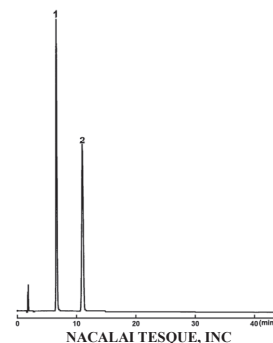

AP-0742

(1) Drugs

● Mepivacaine Hydrochloride

COSMOSIL Application Data

Column: 5C₁₈-AR-II
Column size: 4.6mmI.D.-150mm
Mobile phase: 10mmol/l Sodium Lauryl Sulfate-Acetonitrile/
20mmol/l Phosphate Buffer(pH3.0) = 45/55
Flow rate: 1.0 ml/min
Temperature: 30°C
Detection: UV254nm

Sample: 1; Mepivacaine (2.0µg)
2; Benzophenone (0.04µg)

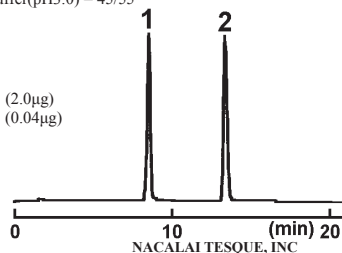

AP-0746

● Meropenem

COSMOSIL Application Data

Column: 5C₁₈-AR-II
Column size: 4.6mmI.D.-150mm
Mobile phase: Methanol/ 0.1%Triethylamine
(pH5.0 with H₃PO₄) = 10/90
Flow rate: 1.0 ml/min
Temperature: 25°C
Detection: UV220nm

Sample: 1; Meropenem (2.5µg)
2; Benzyl Alcohol (1.5µg)

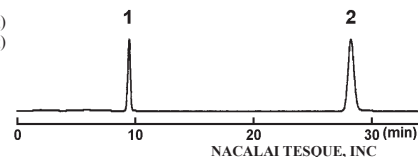

AP-0749

● Ubidecarenone

COSMOSIL Application Data

Column: 5C₁₈-PAQ
Column size: 4.6mmI.D.-150mm
Mobile phase: Methanol/ Ethanol = 50/50
Flow rate: 0.5 ml/min
Temperature: 35°C
Detection: UV275nm

Sample: 1; Coenzyme Q10 [Ubidecarenone] (2.5µg)



NACALAI TESQUE, INC

AP-0900

● Iodine, Salicylic Acid and Phenol

COSMOSIL Application Data

Column: 5C₁₈-MS-II
Column size: 4.6mmI.D.-250mm
Mobile phase: Methanol/ 100mmol/l Phosphate
Buffer(pH7.0) = 25/75
Flow rate: 1.0 ml/min
Temperature: 30°C
Detection: UV270nm

Sample: 1; Benzoic Acid (2.0µg)
2; Theophylline (0.5µg)
3; Salicylic Acid (2.0µg)
4; Phenol (2.0µg)

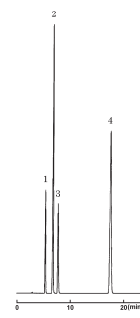

NACALAI TESQUE, INC

AP-0935

● Latamoxef Sodiums

COSMOSIL Application Data

Column: 5C₁₈-MS-II
Column size: 4.6mmI.D.-150mm
Mobile phase: Methanol/ 51mmol/l KH₂PO₄,
9mmol/l Na₂HPO₄,
5mmol/l Tetra-*n*-Butylammonium Bromide
= 25/75
Flow rate: 1.0 ml/min
Temperature: 25°C
Detection: UV254nm

Sample: 1; 5-Mercapto-*l*-Methyltetrazole (1.65µg)
2; Latamoxef (isomer 1)
3; Latamoxef (isomer 2)
4; *m*-Cresol (7.5µg)

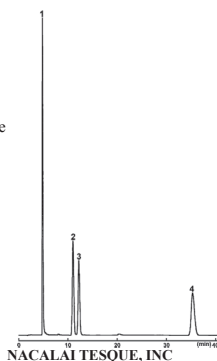

NACALAI TESQUE, INC

AP-0711

● Latamoxef Sodiums

COSMOSIL Application Data

Column: 5C₁₈-PAQ
Column size: 4.6mmI.D.-150mm
Mobile phase: Methanol/ 100mmol/l Ammonium
Acetate = 5/95
Flow rate: 1.0 ml/min
Temperature: 25°C
Detection: UV254nm

Sample: 1; Latamoxef (isomer 1)
2; Latamoxef (isomer 2)

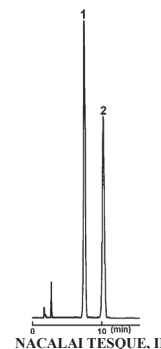

NACALAI TESQUE, INC

AP-0716

● Liothyronine Sodium

COSMOSIL Application Data

Column: 5C₁₈-PAQ
 Column size: 4.6mmI.D.-250mm
 Mobile phase: Methanol/ H₂O = 60/40
 Flow rate: 1.0 ml/min
 Temperature: 25°C
 Detection: UV220nm

Sample: 1; *n*-Propyl *p*-Hydroxybenzoate (0.14µg)
 2; 3,3',5'-Triiodo-*L*-thyronine (0.08µg)

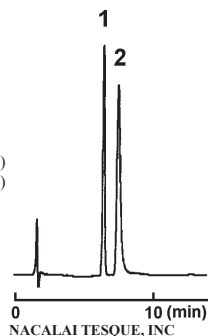

● Lisinopril

COSMOSIL Application Data

Column: 5C₁₈-PAQ
 Column size: 4.6mmI.D.-150mm
 Mobile phase: A; 25mmol/l NaH₂PO₄
 B; Acetonitrile/ 25mmol/l NaH₂PO₄ = 40/60
 B conc. 10→50%(0→10min), 50%(10-25min)

Flow rate: 1.5 ml/min
 Temperature: 60°C
 Detection: UV215nm

Sample: 1; Lisinopril (0.45µg)
 2; Caffeine (0.015µg)

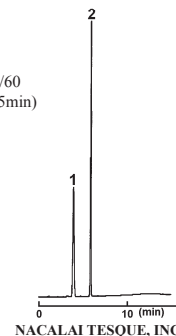

● Lisinopril

COSMOSIL Application Data

Column: 5C₁₈-MS-II
 Column size: 4.6mmI.D.-150mm
 Mobile phase: Acetonitrile/ 25mmol/l NaH₂PO₄
 = 5/95
 Flow rate: 1.0 ml/min
 Temperature: 60°C
 Detection: UV215nm

Sample: 1; Lisinopril (2.0µg)
 2; Caffeine (0.5µg)

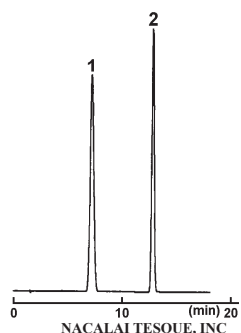

● Lidocaine

COSMOSIL Application Data

Column: 5C₁₈-AR-II
 Column size: 4.6mmI.D.-150mm
 Mobile phase: 10mmol/l Sodium Lauryl Sulfate-Acetonitrile/
 20mmol/l Phosphate Buffer(pH3.0)=45/55
 Flow rate: 1.5 ml/min
 Temperature: 25°C
 Detection: UV254nm

Sample: 1; Lidocaine (8.5µg)
 2; Benzophenone (0.25µg)

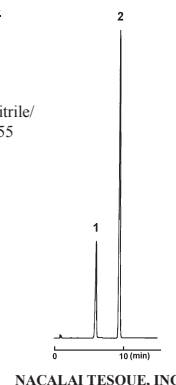

● Ritodrine Hydrochloride

COSMOSIL Application Data

Column: 5C₁₈-AR-II
 Column size: 4.6mmI.D.-150mm
 Mobile phase: Methanol/ 71mmol/l (NH₄)₂HPO₄,
 7.8mmol/l Sodium *I*-Heptanesulfonate
 = 30/70(pH3.0 with H₃PO₄)
 Flow rate: 1.0 ml/min
 Temperature: 25°C
 Detection: UV220nm

Sample: 1; Ritodrine
 2; *threo*-Ritodrine
 3; by-product

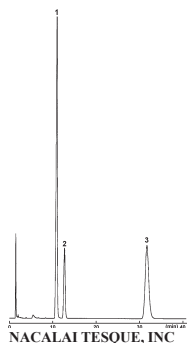

● Ritodrine Hydrochloride

COSMOSIL Application Data

Column: 5C₁₈-AR-II
 Column size: 4.6mmI.D.-150mm
 Mobile phase: Methanol/ 71mmol/l (NH₄)₂HPO₄,
 7.8mmol/l Sodium *I*-Heptanesulfonate
 = 30/70(pH3.0 with H₃PO₄)
 Flow rate: 1.0 ml/min
 Temperature: 25°C
 Detection: UV274nm

Sample: 1; Ritodrine (0.30µg)
 2; Methyl *p*-Hydroxybenzoate (0.05µg)

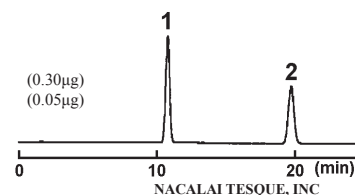

(1) Drugs

● Rifampicin

COSMOSIL Application Data

Column: 5C₈-MS
Column size: 4.6mmI.D.-150mm
Mobile phase: 20mmol/l Citric Acid, 11mmol/l Sodium Perchlorate-Acetonitrile/H₂O/ 1mol/l KH₂PO₄, 55mmol/l H₃PO₄(pH3.1) = 7/11/2
Flow rate: 2.0 ml/min
Temperature: 25°C
Detection: UV254nm

Sample:
1; Butyl *p*-Hydroxybenzoate (0.15μg)
2; Rifampicin (0.80μg)

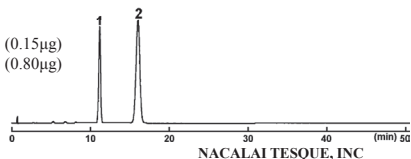

AP-0832

● Rifampicin

COSMOSIL Application Data

Column: 5C₈-MS
Column size: 4.6mmI.D.-250mm
Mobile phase: Acetonitrile/ 15mmol/l Sodium Perchlorate, 28mmol/l Citric Acid, 17mmol/l NaH₂PO₄ = 45/55
Flow rate: 1.0 ml/min
Temperature: 25°C
Detection: UV254nm

Sample: 1; Rifampicin (0.08μg)

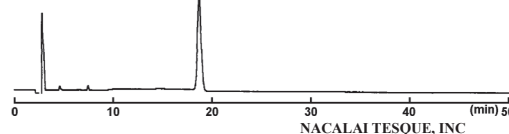

AP-0833

● Lincomycin Hydrochloride

COSMOSIL Application Data

Column: 5C₈-MS
Column size: 4.6mmI.D.-250mm
Mobile phase: Acetonitrile/Methanol/ 1.35% H₃PO₄ (pH6.0 with Ammonia) = 15/15/78
Flow rate: 1.0 ml/min
Temperature: 46°C
Detection: UV210nm

Sample: 1; Lincomycin (20μg)

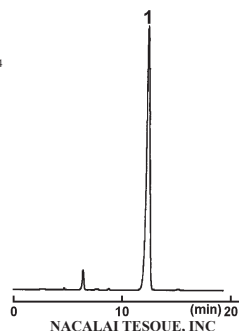

AP-0729

● Reserpine

COSMOSIL Application Data

Column: 5C₁₈-AR-II
Column size: 4.6mmI.D.-250mm
Mobile phase: Acetonitrile/ 50mmol/l KH₂PO₄ (pH3.0 with H₃PO₄) = 45/55
Flow rate: 0.5 ml/min
Temperature: 40°C
Detection: UV268nm

Sample: 1; Reserpine (0.20μg)
2; Butyl *p*-Hydroxybenzoate (0.08μg)

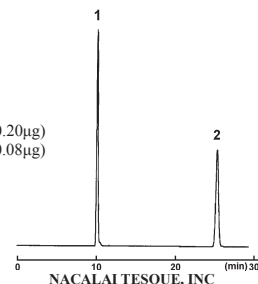

AP-0830

● Levallorphan Tartrate

COSMOSIL Application Data

Column: 5C₁₈-AR-II
Column size: 4.6mmI.D.-150mm
Mobile phase: Acetonitrile/ 7mmol/l Sodium Lauryl Sulfate, 0.1% H₃PO₄(pH3.0 with NaOH) = 40/60
Flow rate: 1.0 ml/min
Temperature: 40°C
Detection: UV280nm

Sample: 1; Isobutyl 4-Hydroxybenzoate (0.3μg)
2; Levallorphan (1.7μg)

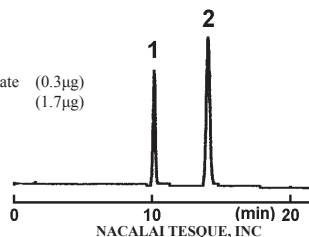

AP-0718

● Levothyroxine

COSMOSIL Application Data

Column: 5C₁₈-AR-II
Column size: 4.6mmI.D.-250mm
Mobile phase: Methanol/ 0.15% H₃PO₄ = 67/33
Flow rate: 1.0 ml/min
Temperature: 25°C
Detection: UV230nm

Sample: 1; Levothyroxine [*L*-Thyroxine] (0.1μg)
2; Ethinylestradiol (0.2μg)

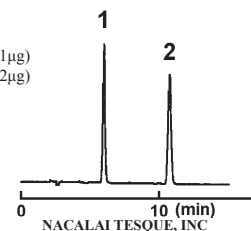

AP-0721

(1) Drugs

● Roxatidine Acetate Hydrochloride

COSMOSIL Application Data

Column: 5C₁₈-MS-II
Column size: 4.6mmI.D.-150mm
Mobile phase: Acetonitrile/ H₂O/ Triethylamine/
Acetic Acid = 60/340/2/1
Flow rate: 1.0 ml/min
Temperature: 40°C
Detection: UV274nm

Sample: 1; Roxatidine Acetate (4.2µg)

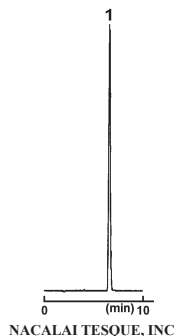

NACALAI TESQUE, INC

AP-0840

● Roxithromycin

COSMOSIL Application Data

Column: 5C₁₈-PAQ
Column size: 4.6mmI.D.-150mm
Mobile phase: Acetonitrile/ 0.2mmol/l (NH₄)H₂PO₄
(pH5.3 with NaOH) = 30/70
Flow rate: 1.0 ml/min
Temperature: 30°C
Detection: UV205nm

Sample: 1; Roxithromycin (1.0µg)

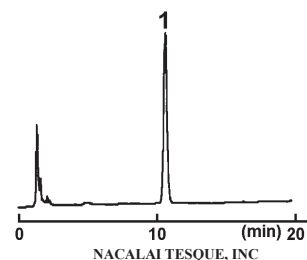

NACALAI TESQUE, INC

AP-0845

● Tricyclic Drugs

COSMOSIL Application Data

Column: 5C₁₈-MS-II
Column size: 4.6mmI.D.-150mm
Mobile phase: Methanol/ 20mmol/l Phosphate
Buffer(pH7) = 60/40
Flow rate: 1.0 ml/min
Temperature: 30°C
Detection: UV254nm, 0.2AUFS

Sample: 1; Carbamazepine
2; Desipramine
3; Imipramine

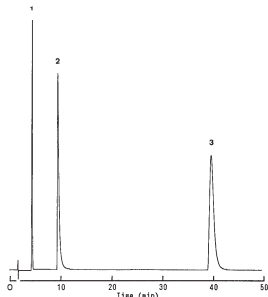

NACALAI TESQUE, INC

AP-0066

● Bronchodilators

COSMOSIL Application Data

Column: 5C₁₈-AR-II
Column size: 4.6mmI.D.-150mm
Mobile phase: Methanol/ H₂O = 30/70
Flow rate: 1.0 ml/min
Temperature: 30°C
Detection: UV254nm, 1.0AUFS

Sample: 1; Uracil (0.5µg)
2; Theobromine (1.5µg)
3; Theophylline (2.0µg)
4; Caffeine (2.0µg)
5; Phenol (0.8µg)

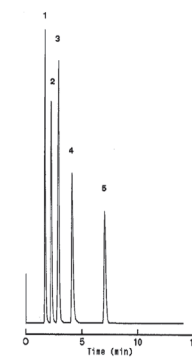

NACALAI TESQUE, INC

AP-0076

● Antiarrhythmic Drugs

COSMOSIL Application Data

Column: 5C₁₈-MS-II
Column size: 4.6mmI.D.-150mm
Mobile phase: Methanol/ 20mmol/l Phosphate
Buffer(pH7) = 60/40
Flow rate: 1.0 ml/min
Temperature: 30°C
Detection: UV254nm, 0.05AUFS

Sample: 1; Phenytoin [5,5-Diphenylhydantoin]
2; Ketamine
3; Quinidine
4; Lidocaine

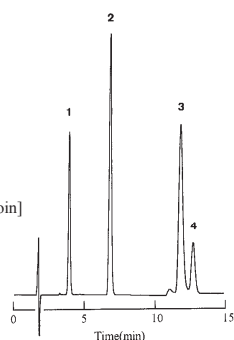

NACALAI TESQUE, INC

AP-0067

● Antiarrhythmic Drugs

COSMOSIL Application Data

Column: 5C₁₈-AR-II
Column size: 4.6mmI.D.-150mm
Mobile phase: Methanol/ 20mmol/l Phosphate
Buffer(pH2) = 10/90
Flow rate: 1.0 ml/min
Temperature: 30°C
Detection: UV254nm, 0.2AUFS

Sample: 1; Procainamide (0.5µg)
2; N-Acetylprocainamide (0.5µg)

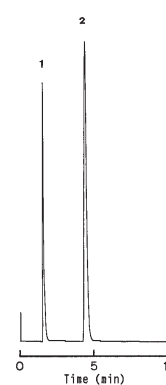

NACALAI TESQUE, INC

AP-0069

(1) Drugs

• Antiepileptics

COSMOSIL Application Data

Column: 5C₁₈-MS-II
Column size: 4.6mmI.D.-150mm
Mobile phase: Methanol/ 20mmol/l Phosphate
Buffer(pH7) = 50/50
Flow rate: 1.0 ml/min
Temperature: 30°C
Detection: UV254nm, 0.5AUFS

Sample:
1; Barbital (7.59µg)
2; Phenytoin [5,5-Diphenylhydantoin] (10.38µg)
3; Carbamazepine (1.02µg)

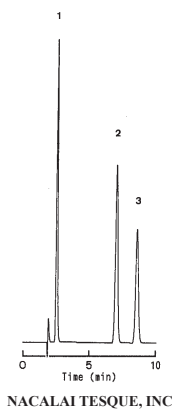

NACALAI TESQUE, INC

AP-0077

• Analgesics

COSMOSIL Application Data

Column: 5C₁₈-AR-II
Column size: 4.6mmI.D.-150mm
Mobile phase: Methanol / 20mmol/l Phosphoric Acid
= 40/60
Flow rate: 1.0 ml/min
Temperature: 30°C
Detection: UV254nm, 0.5AUFS

Sample: 1; 4-Aminoantipyrine (0.74µg)
2; *p*-Acetamidophenol (2.97µg)
3; Antipyrine (0.85µg)
4; Acetylsalicylic Acid [Aspirine]
5; Phenacetin (0.54µg)
6; Salicylic acid

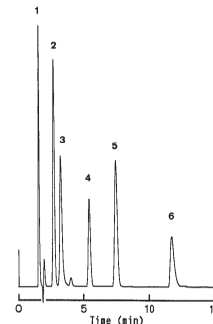

NACALAI TESQUE, INC

AP-0073

• Analgesics

COSMOSIL Application Data

Column: SSL-II
Column size: 4.6mmI.D.-250mm
Mobile phase: Ethyl Acetate/Hexane =1/1
Flow rate: 1.0 ml/min
Temperature: 30°C
Detection: UV254nm, 0.2AUFS

Sample: 1; Acetanilide (1.0µg)
2; Phenacetin (1.0µg)
3; *p*-Acetamidophenol (1.0µg)

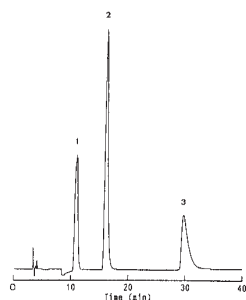

NACALAI TESQUE, INC

AP-0074

• Histamine H1-Receptor Blockers

COSMOSIL Application Data

Column: 5C₁₈-MS-II
Column size: 4.6mmI.D.-150mm
Mobile phase: Acetonitrile/ 10mmol/l SDS,
0.1% Phosphoric Acid = 60/40
Flow rate: 1.0 ml/min
Temperature: 30°C
Detection: UV254nm

Sample: 1; Uracil
2; Diphenhydramine



NACALAI TESQUE, INC

AP-0078

• Histamine H2-Receptor Blockers

COSMOSIL Application Data

Column: 5C₁₈-MS-II
Column size: 4.6mmI.D.-150mm
Mobile phase: Methanol/ 20mmol/l Phosphate
buffer(pH7) = 30/70
Flow rate: 1.0 ml/min
Temperature: 30°C
Detection: UV254nm, 0.2AUFS

Sample: 1; Famotidine (1.3µg)
2; Cimetidine (33.5µg)
3; Ranitidine (1.6µg)

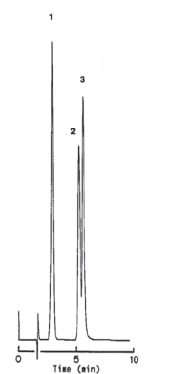

NACALAI TESQUE, INC

AP-0079

• Antihyperlipidemic Drugs

COSMOSIL Application Data

Column: 5C₁₈-MS-II
Column size: 4.6mmI.D.-150mm
Mobile phase: Methanol / 20mmol/l Phosphoric Acid
= 10/90
Flow rate: 1.0 ml/min
Temperature: 30°C
Detection: UV254nm, 0.5AUFS

Sample: 1; Hydralazine (1.0µg)
2; Todralazine (1.0µg)

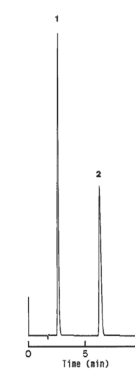

NACALAI TESQUE, INC

AP-0080

(1) Drugs

• Profens

COSMOSIL Application Data

Column: 5C₁₈-MS-II
Column size: 4.6mmI.D.-150mm
Mobile phase: Acetonitrile/ 20mmol/l Acetic Acid = 60/40
Flow rate: 1.0 ml/min
Temperature: 30°C
Detection: UV220nm, 1.0AUFS

Sample: 1; Ketoprofen (1.60µg)
2; Ibuprofen (1.69µg)
3; Flurbiprofen (1.57µg)

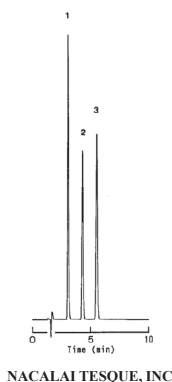

NACALAI TESQUE, INC

AP-0081

• Cardiac Glycosides

COSMOSIL Application Data

Column: 5C₁₈-AR-II
Column size: 4.6mmI.D.-150mm
Mobile phase: Methanol/ H₂O = 70/30
Flow rate: 1.0 ml/min
Temperature: 30°C
Detection: UV230nm, 0.32AUFS

Sample: 1; Digitoxigenin (2.5µg)
2; Digitoxin (5.0µg)

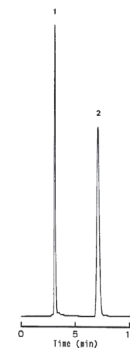

NACALAI TESQUE, INC

AP-0083

• Anticancer Drugs

COSMOSIL Application Data

Column: Sugar-D
Column size: 4.6mmI.D.-150mm
Mobile phase: Acetonitrile/H₂O = 80/20
Flow rate: 0.3 ml/min
Temperature: Room temperature
Detection: UV226nm

Sample: 1; *cis*-Platin (CDDP) (1.46µg)
2; Guanosine (0.50µg)

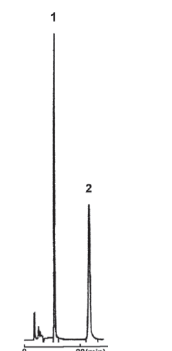

NACALAI TESQUE, INC

AP-0380

Data courtesy of Dr.K.Kofuji, Hokuriku University

• Tetracyclines Antibiotics

COSMOSIL Application Data

Column: 5C₁₈-MS-II
Column size: 4.6mmI.D.-150mm
Mobile phase: Methanol/ 20mmol/l Phosphate buffer(pH3) = 20/80
Flow rate: 1.0 ml/min
Temperature: 20°C
Detection: UV254nm

Sample: 1; Oxytetracycline
2; Tetracycline
3; Chlortetracycline

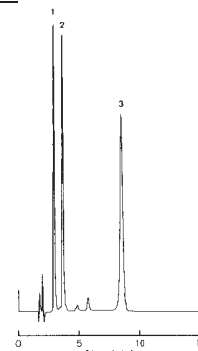

NACALAI TESQUE, INC

AP-0085

• Penicillin Antibiotics

COSMOSIL Application Data

Column: 5C₁₈-MS-II
Column size: 4.6mmI.D.-150mm
Mobile phase: Methanol/ 20mmol/l Phosphate Buffer(pH7) = 50/50
Flow rate: 1.0 ml/min
Temperature: 30°C
Detection: UV235nm, 0.2AUFS

Sample: 1; Carbenicillin (1.5µg)
2; Ampicillin (3.0µg)
3; Methicillin (1.5µg)
4; Penicillin G (3.0µg)

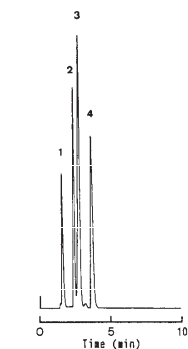

NACALAI TESQUE, INC

AP-0086

• Quinolone Antimicrobials

COSMOSIL Application Data

Column: 5C₁₈-MS-II
Column size: 4.6mmI.D.-150mm
Mobile phase: Methanol/ 20mmol/l Phosphate Buffer(pH3) = 55/45
Flow rate: 1.0 ml/min
Temperature: 30°C
Detection: UV270nm, 0.16AUFS

Sample: 1; Ofloxacin (0.39µg)
2; Oxolinic Acid (0.08µg)
3; Flumequine (1.08µg)
4; Piroimidic Acid (0.08µg)

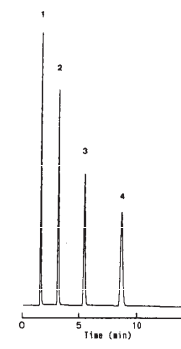

NACALAI TESQUE, INC

AP-0087

(1) Drugs

● Nitrofuran Antimicrobials

COSMOSIL Application Data

Column: 5C₁₈-AR-II
Column size: 4.6mmI.D.-150mm
Mobile phase: Methanol / 20mmol/l Phosphoric Acid = 20/80
Flow rate: 1.0 ml/min
Temperature: 30°C
Detection: UV260nm, 0.5AUFS

Sample: 1; Nitrofurantoin (1.0µg)
2; Nitrofurazone (1.0µg)

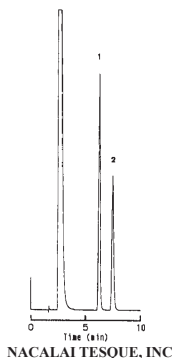

NACALAI TESQUE, INC

AP-0089

● Streptomycin Sulfate

COSMOSIL Application Data

Column: 5C₁₈-MS-II
Column size: 4.6mmI.D.-150mm
Mobile phase: Acetonitrile/ 5mmol/l Sodium /-Hexanesulfonate, 20mmol/l KH₂PO₄ = 10/90

Flow rate: 1.0 ml/min
Temperature: 30°C
Detection: UV205nm, 0.2AUFS

Sample: Streptomycin Sulfate (5.0µg)

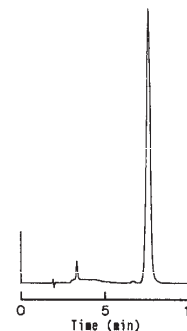

NACALAI TESQUE, INC

AP-0091

● Sulfa Drugs

COSMOSIL Application Data

Column: 5C₁₈-MS-II
Column size: 4.6mmI.D.-150mm
Mobile phase: Methanol / 20mmol/l Phosphoric Acid = 30/70
Flow rate: 1.0 ml/min
Temperature: 30°C
Detection: UV230nm, 0.5AUFS

Sample: 1; Sulfaisomidin (0.24µg)
2; Sulfathiazole (0.24µg)
3; Sulfamethazine (0.24µg)
4; Sulfamethoxyipyridazine (0.24µg)
5; Sulfamethoxazole (0.24µg)
6; Sulfachloropyridazine (0.24µg)
7; Sulfamonomethoxine (0.24µg)
8; Sulfadimethoxine (0.24µg)

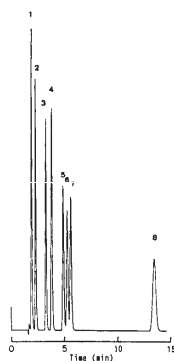

NACALAI TESQUE, INC

AP-0090

● Allantoin

COSMOSIL Application Data

Column: HILIC
Column size: 4.6mmI.D.-250mm
Mobile phase: Acetonitrile/ 10mmol/l Phosphate Buffer(pH7.0) = 70/30
Flow rate: 1.0 ml/min
Temperature: 30°C
Detection: UV210nm

Sample: 1; Allantoin
2; Allantoic Acid

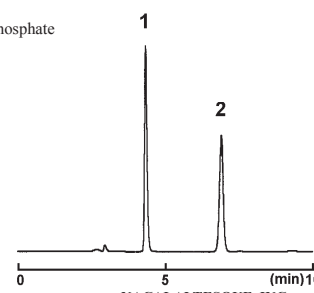

NACALAI TESQUE, INC

AP-1060

● Tonic Drug

COSMOSIL Application Data

Column: 5PBB-R
Column size: 4.6mmI.D.-150mm
Mobile phase: A: Acetonitrile/ 50mmol/l NaH₂PO₄ = 20/80(pH2.5 with H₃PO₄)
B: Acetonitrile/ 50mmol/l NaH₂PO₄ = 80/20(pH2.5 with H₃PO₄)
B conc. 15→20% (0-20min), 20→100% (20-35min), 100%(35-40min), 15%(40-55min)

Flow rate: 1.0 ml/min
Temperature: 40°C
Detection: UV290nm

Sample:
1; Vardenafil
2; Hydroxyhongdenafil
3; Hongdenafil
4; Thioquinapiperil
5; Hydroxyhomosildenafil
6; Sildenafil
7; Homosildenafil
8; Aildenafil
9; Udenafil
10; Aminotadalafil
11; Acetil Acid
12; Tadalafil
13; Xanthoantrafil
14; Thiodenafil
15; Thioaildenafil
16; Imidazosagatriadinone

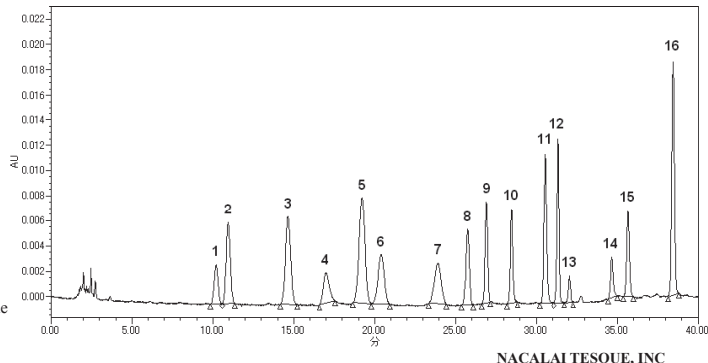

NACALAI TESQUE, INC

AP-1192

Data courtesy of a customer

(2) Crude Drugs

● Bearberry Leaf

COSMOSIL Application Data

Column: 5C₁₈-PAQ
Column size: 4.6mmI.D.-250mm
Mobile phase: Methanol/ 1mmol/l HCl = 5/95
Flow rate: 1.0 ml/min
Temperature: 30°C
Detection: UV280nm

Sample: 1; Arbutin (5.0µg)
2; Hydroquinone (5.0µg)
3; Gallic Acid (5.0µg)

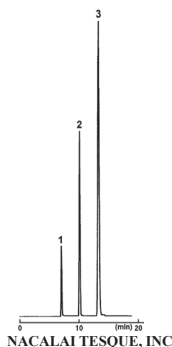

● Scutellaria Root

COSMOSIL Application Data

Column: 5C₁₈-AR-II
Column size: 4.6mmI.D.-150mm
Mobile phase: Acetonitrile/ 0.68% Phosphoric Acid = 28/72
Flow rate: 1.0 ml/min
Temperature: 50°C
Detection: UV277nm

Sample: 1; Baicalin (0.1µg)
2; Methyl *p*-Hydroxybenzoate (0.2µg)

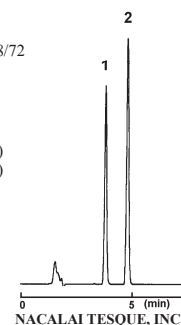

● Phellodendron Bark

COSMOSIL Application Data

Column: 5C₁₈-PAQ
Column size: 4.6mmI.D.-250mm
Mobile phase: Acetonitrile/ 5.9mmol/l Sodium Lauryl Sulfate,
25mmol/l KH₂PO₄ = 50/50
Flow rate: 1.0 ml/min
Temperature: 40°C
Detection: UV345nm

Sample: 1; Palmatine (1.0µg)
2; Berberine (1.0µg)

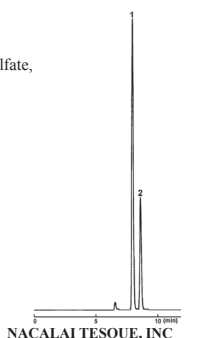

● Pueraria Root

COSMOSIL Application Data

Column: 5C₁₈-MS-II
Column size: 4.6mmI.D.-150mm
Mobile phase: Acetonitrile/ 50mmol/l NaH₂PO₄
= 10/90
Flow rate: 0.5 ml/min
Temperature: 40°C
Detection: UV250nm

Sample: 1; Puerarin (1.3µg)

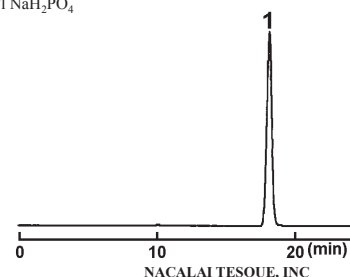

● Kamishoyosan Extract

COSMOSIL Application Data

Column: 5C₁₈-AR-II
Column size: 4.6mmI.D.-150mm
Mobile phase: Acetonitrile/ 0.11% H₃PO₄ = 10/90
Flow rate: 1.0 ml/min
Temperature: 40°C
Detection: UV240nm

Sample: 1; Geniposide (1.2µg)

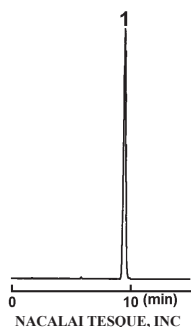

● Glycyrrhiza

COSMOSIL Application Data

Column: 5C₁₈-AR-II
Column size: 4.6mmI.D.-250mm
Mobile phase: Acetonitrile/ 2% H₃PO₄ = 40/60
Flow rate: 1.0 ml/min
Temperature: 30°C
Detection: UV254nm

Sample: 1; Glycyrrhizic Acid [Glycyrrhizin] (5.0µg)
2; *n*-Propyl *p*-Hydroxybenzoate (1.0µg)

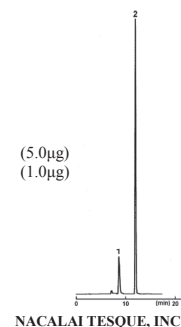

(2) Crude Drugs

● Dried Yeast

COSMOSIL Application Data

Column: 5C₁₈-PAQ
Column size: 4.6mmI.D.-150mm
Mobile phase: Acetonitrile/ 9.2mmol/l Sodium *I*-Octanesulfonate,
20mmol/l KH₂PO₄(pH3.5 with H₃PO₄) = 20/80
Flow rate: 1.0 ml/min
Temperature: 40°C
Detection: UV254nm

Sample: 1; Vitamin B₁ [Thiamine] (0.10µg)
2; Phenacetin (0.06µg)

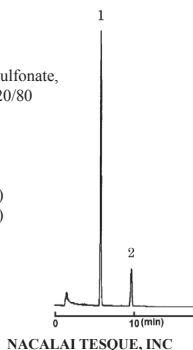

NACALAI TESQUE, INC

AP-0919

● Keishibukuryougan Extract

COSMOSIL Application Data

Column: 5C₁₈-MS-II
Column size: 4.6mmI.D.-150mm
Mobile phase: Methanol/ 50mmol/l NaH₂PO₄ = 1/5
Flow rate: 0.8 ml/min
Temperature: 45°C
Detection: UV210nm

Sample: 1; *D*-(-)-Amygdalin (2.0µg)

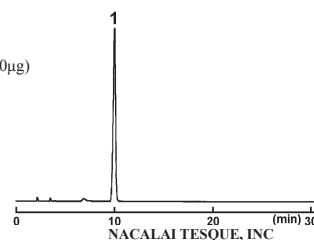

NACALAI TESQUE, INC

AP-0944

● Red Ginseng and Ginseng

COSMOSIL Application Data

Column: 5C₁₈-PAQ
Column size: 4.6mmI.D.-150mm
Mobile phase: Acetonitrile/ H₂O = 20/80
Flow rate: 1.0 ml/min
Temperature: 30°C
Detection: UV203nm

Sample: 1; Ginsenoside Rg1 (2.5µg)
2; Ginsenoside Re (2.5µg)

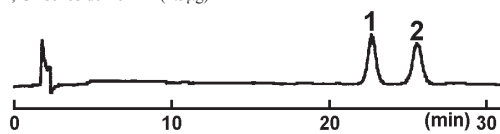

NACALAI TESQUE, INC

AP-0922

● Red Ginseng and Ginseng

COSMOSIL Application Data

Column: 5C₁₈-MS-II
Column size: 4.6mmI.D.-150mm
Mobile phase: Acetonitrile/ H₂O = 30/70
Flow rate: 1.0 ml/min
Temperature: 40°C
Detection: UV203nm

Sample: 1; Ginsenoside Rb1 (2.5µg)
2; Ginsenoside Rc (2.5µg)

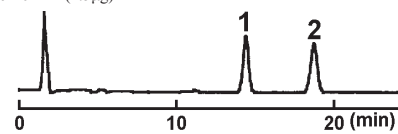

NACALAI TESQUE, INC

AP-0923

● Magnolia Bark

COSMOSIL Application Data

Column: 5C₁₈-AR-II
Column size: 4.6mmI.D.-150mm
Mobile phase: Acetonitrile/ 2%Acetic Acid = 50/50
Flow rate: 1.0 ml/min
Temperature: 30°C
Detection: UV289nm

Sample: 1; Honokiol (1.0µg)
2; Magnolol (1.0µg)

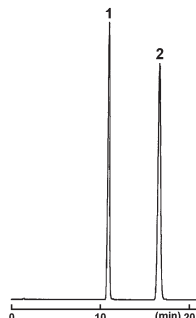

NACALAI TESQUE, INC

AP-0948

● Bupleurum Root

COSMOSIL Application Data

Column: 5C₁₈-MS-II
Column size: 4.6mmI.D.-150mm
Mobile phase: Acetonitrile/ H₂O = 40/60
Flow rate: 1.0 ml/min
Temperature: 50°C
Detection: UV206nm

Sample: 1; Saikosaponin a (1.0µg)
2; Saikosaponin d (1.0µg)

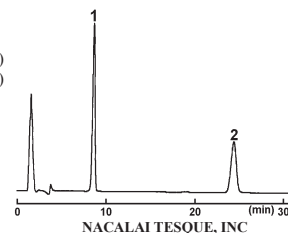

NACALAI TESQUE, INC

AP-0910

(2) Crude Drugs

● Saireito Extract

COSMOSIL Application Data

Column: 5C₁₈-MS-II
Column size: 4.6mmI.D.-150mm
Mobile phase: Acetonitrile/ 50mmol/l NaH₂PO₄ = 3/5
Flow rate: 1.0 ml/min
Temperature: 40°C
Detection: UV254nm

Sample: 1; Saikosaponin b₂ (1.0µg)



AP-0978

● Saireito Extract

COSMOSIL Application Data

Column: 5C₁₈-MS-II
Column size: 4.6mmI.D.-150mm
Mobile phase: Acetonitrile/ 0.5%H₃PO₄ = 24/76
Flow rate: 1.0 ml/min
Temperature: 40°C
Detection: UV277nm

Sample: 1; Baicalin (0.5µg)

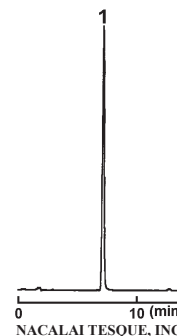

AP-0981

● Powdered Gardenia Fruit

COSMOSIL Application Data

Column: 5C₁₈-MS-II
Column size: 4.6mmI.D.-150mm
Mobile phase: Acetonitrile/ H₂O = 60/40
Flow rate: 0.5 ml/min
Temperature: 30°C
Detection: UV240nm

Sample: 1; Caffeine (0.175µg)
2; Geniposide (0.175µg)

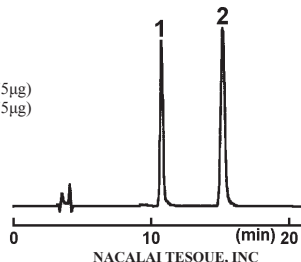

AP-0966

● Peony Root

COSMOSIL Application Data

Column: 5C₁₈-AR-II
Column size: 4.6mmI.D.-150mm
Mobile phase: Acetonitrile/ 0.12%H₃PO₄ = 15/85
Flow rate: 1.0 ml/min
Temperature: 30°C
Detection: UV232nm

Sample: 1; Albiflorin (1.0µg)
2; Paeoniflorin (1.0µg)

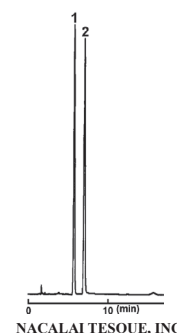

AP-0960

● Toad Venom

COSMOSIL Application Data

Column: 5C₁₈-AR-II
Column size: 4.6mmI.D.-150mm
Mobile phase: Acetonitrile/ 0.1%H₃PO₄ = 45/55
Flow rate: 1.0 ml/min
Temperature: 40°C
Detection: UV300nm

Sample:
1; Bufalin (0.4µg)
2; Cinobufagin (0.4µg)
3; Resibufogenin (0.6µg)
4; Indometacin[Indomethacin](0.6µg)

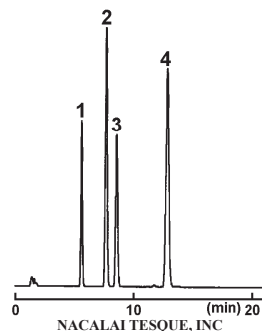

AP-1000

● Senna Leaf

COSMOSIL Application Data

Column: 5C₁₈-MS-II
Column size: 4.6mmI.D.-250mm
Mobile phase: 5mmol/l Tetra-*n*-heptylammonium Bromide-
Acetonitrile/ 0.1mol/l Acetic Acid,
1% Sodium Acetate(pH5.0) = 32/68
Flow rate: 1.0 ml/min
Temperature: 50°C
Detection: UV340nm

Sample: 1; Sennoside B (1.0µg)
2; Sennoside A (0.5µg)

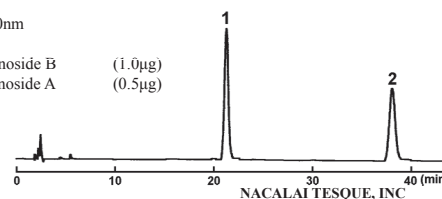

AP-0993

(2) Crude Drugs

● Swertia Herb

COSMOSIL Application Data

Column: 5C₁₈-MS-II
Column size: 4.6mmI.D.-150mm
Mobile phase: Acetonitrile/ H₂O = 10/90
Flow rate: 0.5 ml/min
Temperature: 50°C
Detection: UV238nm

Sample: 1; Theophylline (1.0µg)
2; Swertiamarin (1.0µg)

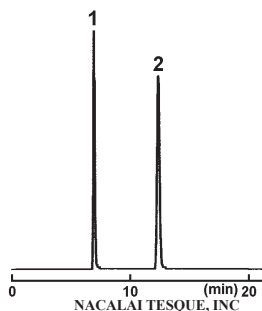

AP-0996

● Rhubarb

COSMOSIL Application Data

Column: 5C₁₈-MS-II
Column size: 4.6mmI.D.-150mm
Mobile phase: Acetonitrile/ 1.25%Acetic Acid = 20/80
Flow rate: 0.5 ml/min
Temperature: 40°C
Detection: UV340nm

Sample: 1; Sennoside A (2.0µg)
2; Naringin (2.0µg)

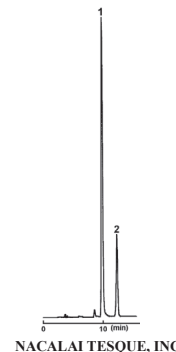

AP-0972

● Daikokanzoto Extract

COSMOSIL Application Data

Column: 5C₁₈-PAQ
Column size: 4.6mmI.D.-150mm
Mobile phase: Acetonitrile/ 0.04%H₃PO₄ = 540/2460
Flow rate: 1.0 ml/min
Temperature: 30°C
Detection: UV340nm

Sample: 1; Sennoside A (0.26µg)

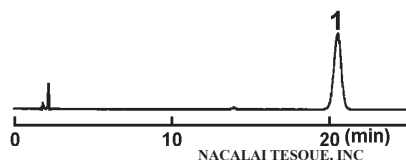

AP-0916

● Capsicum

COSMOSIL Application Data

Column: 5PE-MS
Column size: 4.6mmI.D.-250mm
Mobile phase: Acetonitrile/ 0.1%H₃PO₄ = 40/60
Flow rate: 1.0 ml/min
Temperature: 30°C
Detection: UV281nm

Sample: 1; *N*-Vanillylnonanamide (0.4µg)
2; Capsaicin (0.4µg)

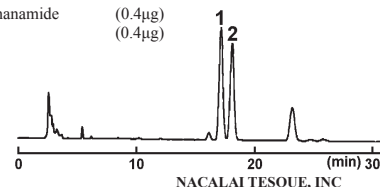

AP-0913

● Ipecac

COSMOSIL Application Data

Column: 5C₁₈-MS-II
Column size: 4.6mmI.D.-150mm
Mobile phase: Methanol/ 20mmol/l Sodium *I*-Heptanesulfonate (pH4.0 with Acetic Acid) = 50/50
Flow rate: 1.0 ml/min
Temperature: 50°C
Detection: UV283nm

Sample: 1; Cephalexin (2.0µg)
2; Emetine (0.5µg)

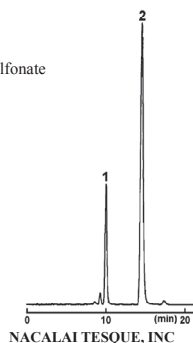

AP-0938

● Belladonna Root

COSMOSIL Application Data

Column: 5C₁₈-PAQ
Column size: 4.6mmI.D.-150mm
Mobile phase: Acetonitrile/ 50mmol/l KH₂PO₄, 1%Triethylamine(pH3.5 with H₃PO₄) = 10/90
Flow rate: 1.0 ml/min
Temperature: 30°C
Detection: UV210nm

Sample: 1; Atropine (2.0µg)
2; Brucine (0.5µg)

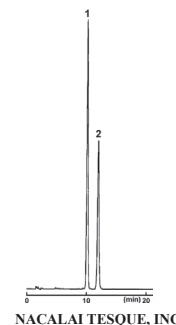

AP-0909

(2) Crude Drugs

● Moutan Bark

COSMOSIL Application Data

Column: 5C₁₈-MS-II
Column size: 4.6mmI.D.-250mm
Mobile phase: Acetonitrile/ 3.1%Acetic Acid = 35/65
Flow rate: 1.0 ml/min
Temperature: 30°C
Detection: UV274nm

Sample: 1; Paconol (0.5µg)
2; Butyl *p*-Hydroxybenzoate (2.2µg)

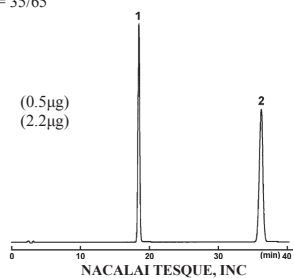

AP-0950

● Hochuekkito Extract

COSMOSIL Application Data

Column: 5C₁₈-AR-II
Column size: 4.6mmI.D.-150mm
Mobile phase: Acetonitrile/ 1.2% H_3PO_4 = 18/82
Flow rate: 1.0 ml/min
Temperature: 40°C
Detection: UV285nm

Sample: 1; Naringin (0.1µg)
2; Vitamin P [Hesperidin] (0.1µg)

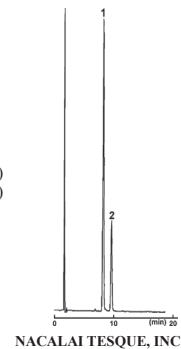

AP-0930

● Povidone

COSMOSIL Application Data

Column: 5C₈-MS
Column size: 4.6mmI.D.-250mm
Mobile phase: Methanol/ H_2O = 20/80
Flow rate: 1.0 ml/min
Temperature: 40°C
Detection: UV254nm

Sample: 1; *N*-Vinyl-2-Pyrrolidone (0.1µg)
2; Vinyl Acetate (5.0µg)

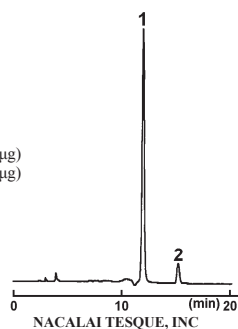

AP-0965

● Nux Vomica

COSMOSIL Application Data

Column: 5C₁₈-PAQ
Column size: 4.6mmI.D.-150mm
Mobile phase: Acetonitrile/ 50mmol/l KH_2PO_4 ,
1.11%Triethylamine = 10/90(pH3.0 with H_3PO_4)
Flow rate: 0.5 ml/min
Temperature: 30°C
Detection: UV210nm

Sample: 1; Strychnine (0.8µg)
2; Barbital (1.1µg)

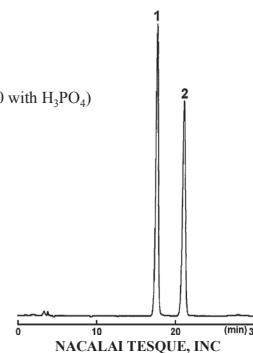

AP-0958

● Ryokeijutukanto Extract

COSMOSIL Application Data

Column: 5C₁₈-AR-II
Column size: 4.6mmI.D.-150mm
Mobile phase: Acetonitrile/ 0.13% H_3PO_4 = 25/75
Flow rate: 1.0 ml/min
Temperature: 40°C
Detection: UV273nm

Sample: 1; *trans*-Cinnamic Acid (0.1µg)

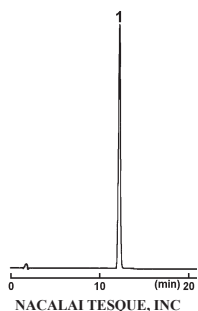

AP-0976

● Scopolia Rhizome and Scopolia Extract

COSMOSIL Application Data

Column: 5C₁₈-PAQ
Column size: 4.6mmI.D.-150mm
Mobile phase: Acetonitrile/ 50mmol/l KH_2PO_4 ,
0.1%Triethylamine(pH3.5 with H_3PO_4)
= 10/90
Flow rate: 1.0 ml/min
Temperature: 30°C
Detection: UV210nm

Sample: 1; Scopolamine (0.6µg)
2; Atropine Sulfate (2.0µg)
3; Brucine (0.4µg)

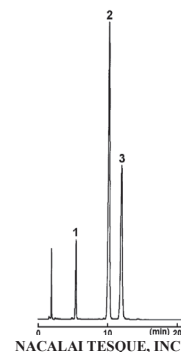

AP-0989

(3) Natural Compounds

● Carotenes

COSMOSIL Application Data

Column: 4.6mm I.D.-150mm
Mobile phase: Tetrahydrofuran/Methanol = 20/80
Flow rate: 1.0 ml/min
Temperature: 30°C
Detection: UV470nm

Sample: 1; α -Carotene
2; β -Carotene

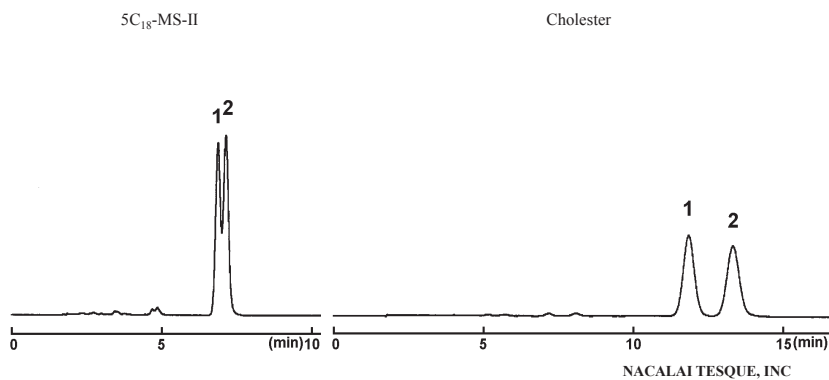

● Flavanones

COSMOSIL Application Data

Column: 4.6mm I.D.-150mm
Mobile phase: Acetonitrile/ 20mmol/l Phosphate Buffer(pH2.5) = 40/60
Flow rate: 1.0 ml/min
Temperature: 30°C
Detection: UV280nm

Sample: 1; Naringin (0.4 μ g)
2; Naringenin (0.2 μ g)
3; Apigenin (0.2 μ g)

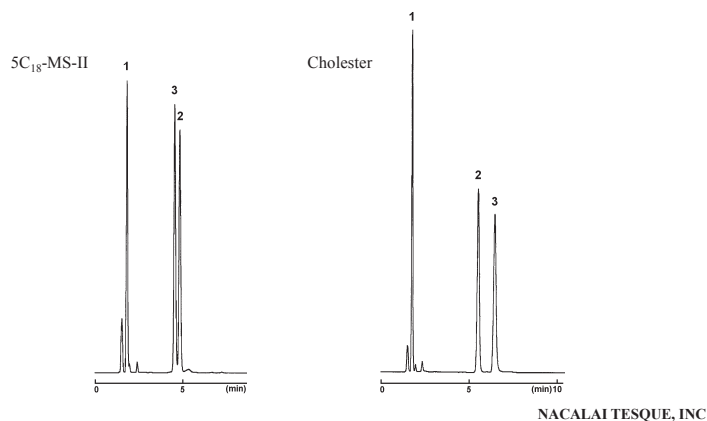

● Saikosaponins

COSMOSIL Application Data

Column: 4.6mm I.D.-150mm
Mobile phase: Acetonitrile/ H₂O = 45/55
Flow rate: 1.0 ml/min
Temperature: 30°C
Detection: ELSD, Gain=6

Sample: 1; Saikosaponin c (1.5 μ g)
2; Saikosaponin a (1.5 μ g)
3; Saikosaponin b₂ (1.5 μ g)
4; Saikosaponin b₁ (1.5 μ g)
5; Saikosaponin d (1.5 μ g)

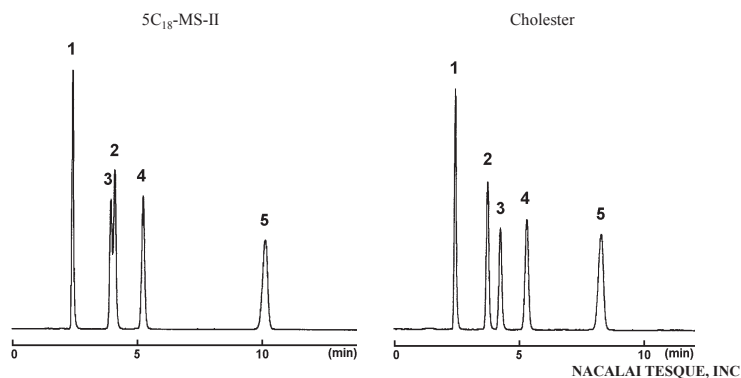

● Hydroxyflavones

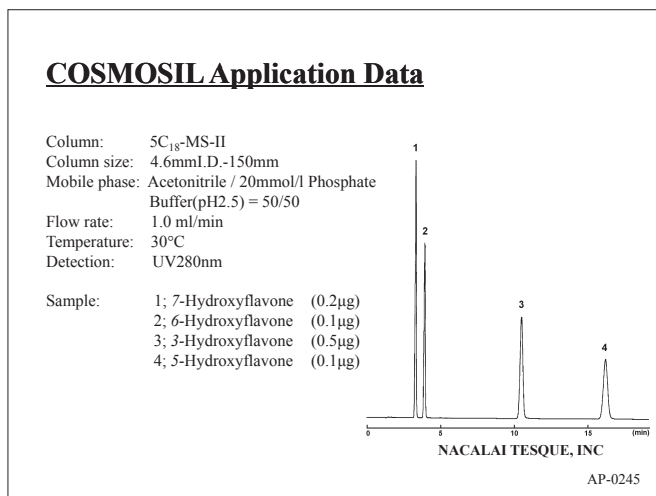

● Chlorophyll

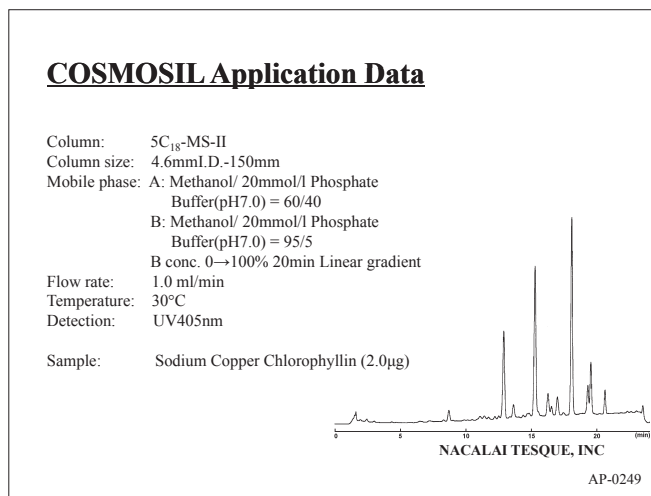

● Coumarins

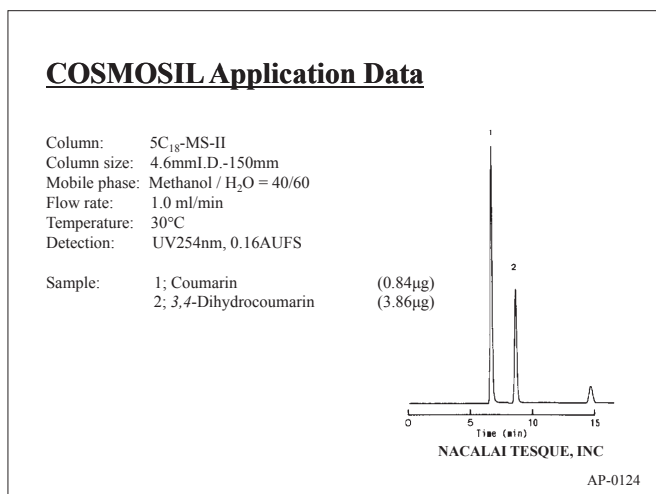

● Hinokitiol

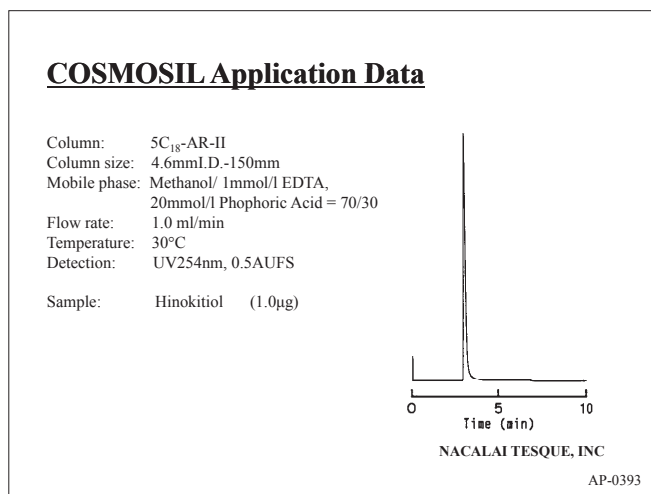

● Anthraquinone Dyes

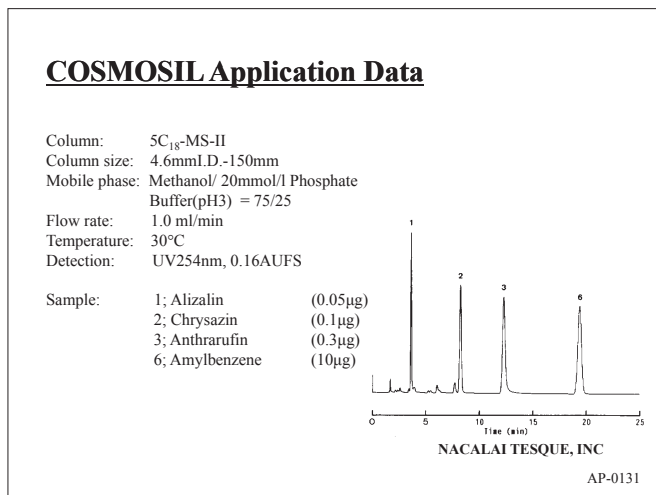

● Anthraquinone Dyes

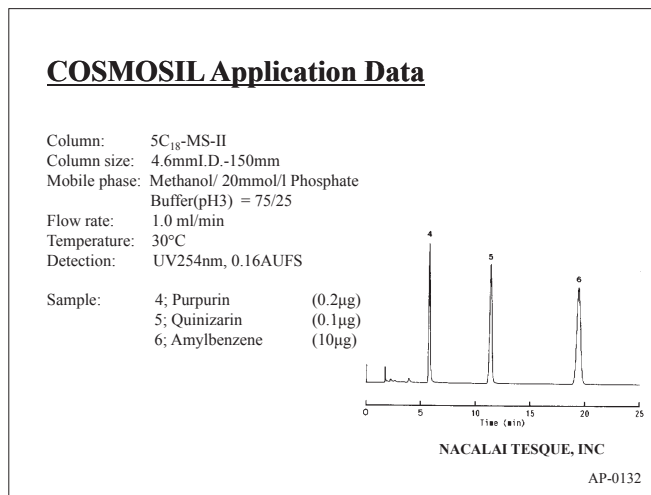

(3) Natural Compounds

● Capsaicin

COSMOSIL Application Data

Column: π NAP
Column size: 4.6mm I.D.-150mm
Mobile phase: Methanol/ H₂O = 70/30
Flow rate: 1.0 ml/min
Temperature: 30°C
Detection: UV280nm

Sample: Capsaicin (2.0 μ g)

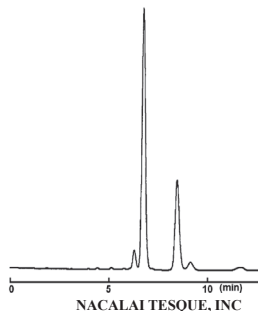

NACALAI TESQUE, INC
AP-0298

● Fungal Toxin

COSMOSIL Application Data

Column: 5C₁₈-AR-II
Column size: 4.6mm I.D.-150mm
Mobile phase: Methanol/ Acetonitrile/ H₂O = 30/10/60
Flow rate: 0.8 ml/min
Temperature: 40°C
Detection: Ex.365nm Em.450nm

Sample: 1; Aflatoxin G2 (13.2ng/ml)
2; Aflatoxin G1 (29.9ng/ml)
3; Aflatoxin B2 (11.8ng/ml)
4; Aflatoxin B1 (25.7ng/ml)

Inj. Vol. 20 μ l

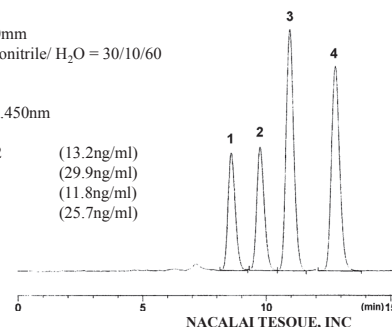

Data courtesy of a customer

NACALAI TESQUE, INC
AP-1148

● Alkaloids

COSMOSIL Application Data

Column: 5C₁₈-MS-II
Column size: 4.6mm I.D.-150mm
Mobile phase: Methanol/ 20mmol/l Phosphate buffer(pH3) = 50/50
Flow rate: 1.0 ml/min
Temperature: 30°C
Detection: UV220nm

Sample: 1; Papaverine (0.17 μ g)
2; Aconitine (8.1 μ g)
3; Reserpine (1.7 μ g)

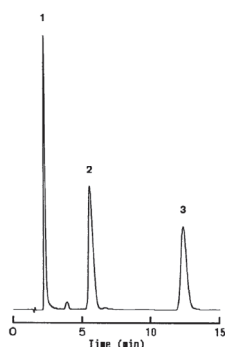

NACALAI TESQUE, INC
AP-0133

● Ginkgo Biloba

COSMOSIL Application Data

Column: 5C₁₈-MS-II
Column size: 4.6mm I.D.-150mm
Mobile phase: Methanol/ H₂O = 40/60
Flow rate: 1.0 ml/min
Temperature: 30°C
Detection: ELSD

Sample: 1; Ginkgolide C (1.3 μ g)
2; Ginkgolide A (1.3 μ g)
3; Ginkgolide B (1.3 μ g)

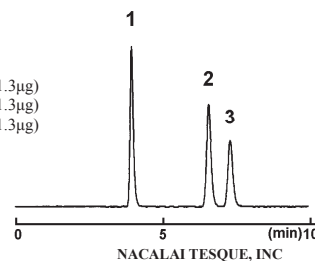

NACALAI TESQUE, INC
AP-1063

● Zingiberis Rhizoma

COSMOSIL Application Data

Column: 5C₁₈-MS-II
Column size: 4.6mm I.D.-150mm
Mobile phase: Acetonitrile/ H₂O = 60/40
Flow rate: 1.0 ml/min
Temperature: 30°C
Detection: UV225nm

Sample: 1; 6-Gingerol (0.31 μ g)
2; 6-Shogaol (0.13 μ g)

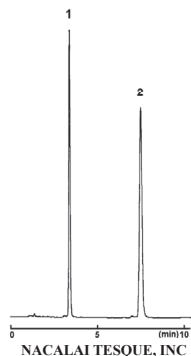

NACALAI TESQUE, INC
AP-1016

● Watermelon

COSMOSIL Application Data

Column: HILIC
Column size: 4.6mm I.D.-250mm
Mobile phase: Acetonitrile/ 20mmol/l Phosphate Buffer(pH7.0) = 70/30
Flow rate: 1.0 ml/min
Temperature: 30°C
Detection: UV210nm

Sample: 1; L-Citrulline (7.5 μ g)
2; L-(-)-Malic Acid (3.8 μ g)

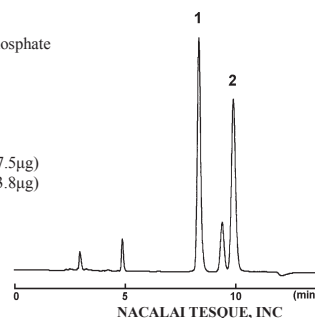

NACALAI TESQUE, INC
AP-1062

(4) Pesticides

● Asulam

COSMOSIL Application Data

Column: 5C₁₈-MS-II
Column size: 4.6mmI.D.-150mm
Mobile phase: Acetonitrile/ 50mmol/l Phosphate
Buffer(pH3) = 15/85
Flow rate: 1.0 ml/min
Temperature: 30°C
Detection: UV270nm

Sample: Asulam

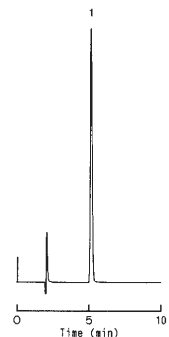

NACALAI TESQUE, INC

AP-0144

● Chlorophenoxyacetic Herbicides

COSMOSIL Application Data

Column: 5C₁₈-MS-II
Column size: 4.6mmI.D.-150mm
Mobile phase: Acetonitrile/ 0.1%Acetic Acid = 50/50
Flow rate: 1.0 ml/min
Temperature: 30°C
Detection: UV275nm, 0.02AUFS

Sample: 1; MCP (0.22µg)
2; MCPP (0.20µg)
3; MCPB (0.24µg)

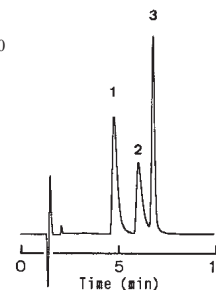

NACALAI TESQUE, INC

AP-0147

● Pesticides used at Golf Course

COSMOSIL Application Data

Column: 5C₁₈-MS-II
Column size: 4.6mmI.D.-150mm
Mobile phase: Acetonitrile/ 50mmol/l Phosphate
buffer(pH3) = 60/40
Flow rate: 1.0 ml/min
Temperature: 30°C
Detection: UV230nm

Sample: 1; Thiram
2; Iprodione
3; Bensulide

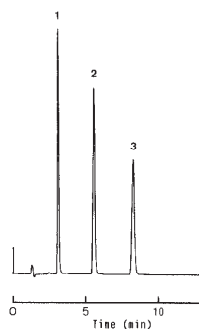

NACALAI TESQUE, INC

AP-0145

● Diphenyl Ether Herbicides

COSMOSIL Application Data

Column: 5C₁₈-MS-II
Column size: 4.6mmI.D.-150mm
Mobile phase: Acetonitrile/ H₂O = 70/30
Flow rate: 1.0 ml/min
Temperature: 30°C
Detection: UV254nm, 0.1AUFS

Sample: 1; Fluorodifen (0.6µg)
2; Chlomethoxynil (1.0µg)
3; Nitrofen (1.0µg)
4; Oxyfluorfen (1.2µg)
5; CNP (1.0µg)

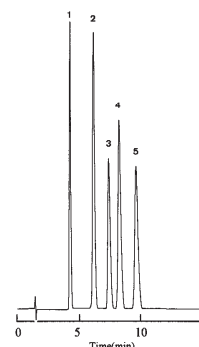

NACALAI TESQUE, INC

AP-0146

● Aniline Herbicides

COSMOSIL Application Data

Column: 5C₁₈-MS-II
Column size: 4.6mmI.D.-150mm
Mobile phase: Acetonitrile/ H₂O = 50/50
Flow rate: 1.0 ml/min
Temperature: 30°C
Detection: UV254nm, 0.1AUFS

Sample: 1; DCMU (0.11µg)
2; DCPA (0.08µg)
3; Linuron (0.11µg)
4; MCC (0.18µg)

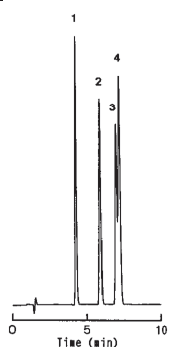

NACALAI TESQUE, INC

AP-0148

● Dithiocarbamate Herbicides

COSMOSIL Application Data

Column: 5C₁₈-MS-II
Column size: 4.6mmI.D.-150mm
Mobile phase: Acetonitrile/ 20mmol/l KH₂PO₄ = 40/60
Flow rate: 1.0 ml/min
Temperature: 30°C
Detection: RI

Sample: 1; Maneb (60µg)
2; Thiram (10µg)

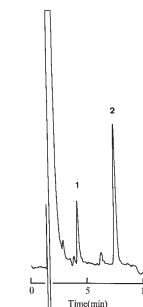

NACALAI TESQUE, INC

AP-0149

(4) Pesticides

● Carbamate Herbicides

COSMOSIL Application Data

Column: 5C₁₈-MS-II
Column size: 4.6mm I.D.-150mm
Mobile phase: Acetonitrile/ H₂O = 30/70
Flow rate: 1.0 ml/min
Temperature: 30°C
Detection: UV254nm, 0.05AUFS

Sample:

1: Methomyl	(0.5µg)
2: Pirimicarb	(0.5µg)
3: MTMC	(2.0µg)
4: PHC	(2.0µg)
5: MPMC	(2.0µg)
6: NAC	(1.0µg)
7: XMC	(1.0µg)
8: Ethiofencarb	(2.0µg)
9: Isoprocarb	(2.0µg)
10: BPMC	(2.0µg)

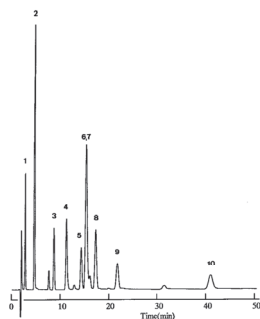

NACALAI TESQUE, INC

AP-0150

● Carbamate Herbicides

COSMOSIL Application Data

Column: 5C₁₈-MS-II
Column size: 4.6mm I.D.-150mm
Mobile phase: Acetonitrile/ H₂O = 80/20
Flow rate: 1.0 ml/min
Temperature: 30°C
Detection: UV254nm, 0.05AUFS

Sample: Carbosulfan (6.0µg)

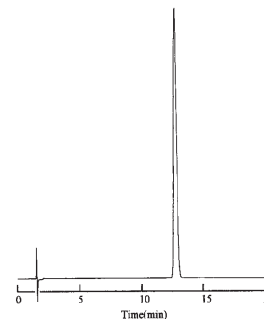

NACALAI TESQUE, INC

AP-0151

● Triazine and Urea Herbicides

COSMOSIL Application Data

Column: 5C₁₈-MS-II
Column size: 4.6mm I.D.-150mm
Mobile phase: Acetonitrile/ 20mmol/l KH₂PO₄ = 40/60
Flow rate: 1.0 ml/min
Temperature: 30°C
Detection: UV254nm, 0.2AUFS

Sample:

1: PAC	(0.5µg)
2: Bromacil	(0.5µg)
3: CAT	(0.5µg)
4: Methabenzthiazuron	(0.5µg)
5: Chlorotoluron	(0.5µg)
6: Isoproturon	(0.5µg)
7: Monolinuron	(0.5µg)
8: Metabromuron	(0.5µg)
9: Dimefuron	(0.5µg)
10: Propazine	(0.5µg)
11: Terbutylazine	(0.5µg)
12: Linuron	(0.5µg)
13: Chloroxuron	(0.5µg)
14: Prometryn	(0.5µg)
15: Terbutryn	(0.5µg)
16: Chloro IPC	(2.5µg)
17: Ethofumesate	(5.0µg)

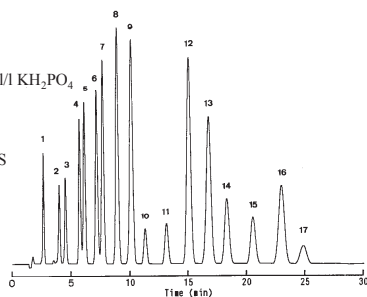

NACALAI TESQUE, INC

AP-0152

● Triazine and Urea Herbicides

COSMOSIL Application Data

Column: 5C₁₈-MS-II
Column size: 4.6mm I.D.-150mm
Mobile phase: Acetonitrile/ 20mmol/l KH₂PO₄ = 30/70
Flow rate: 1.0 ml/min
Temperature: 30°C
Detection: UV254nm, 0.2AUFS

Sample:

1: Ethidimuron	(1.0µg)
2: Metoxuron	(1.0µg)
3: Cyanazine	(1.0µg)
4: Methabenzthiazuron	(1.0µg)
5: Chlorotoluron	(1.0µg)
6: Atrazine	(1.0µg)
7: Isoproturon	(1.0µg)
8: Metabromuron	(1.0µg)
9: Metazachlor	(5.0µg)
10: Propazine	(1.0µg)
11: Terbutylazine	(1.0µg)
12: Linuron	(1.0µg)

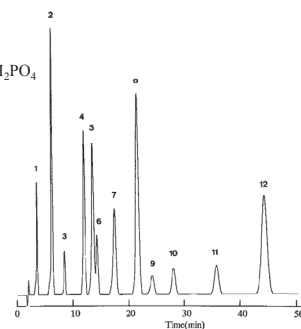

NACALAI TESQUE, INC

AP-0153

(5) Food Additives

• Natural Colorants (Chlorophyll)

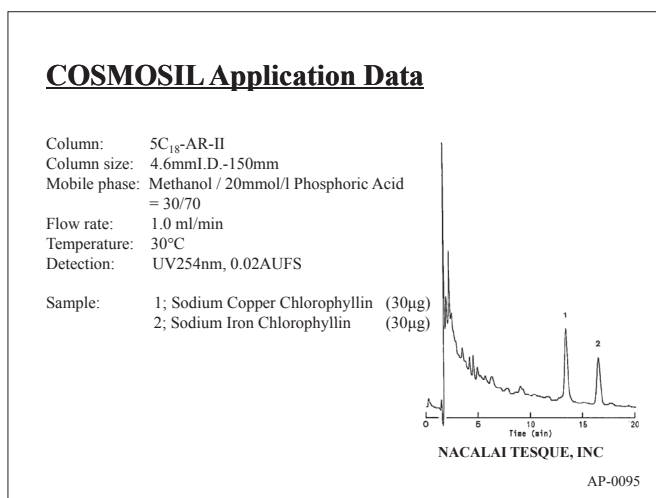

• Natural Colorants (Carotenoid)

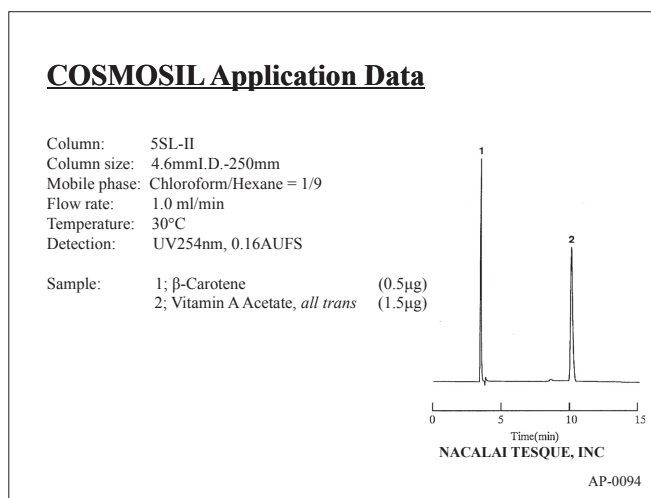

• Synthetic Sweeteners

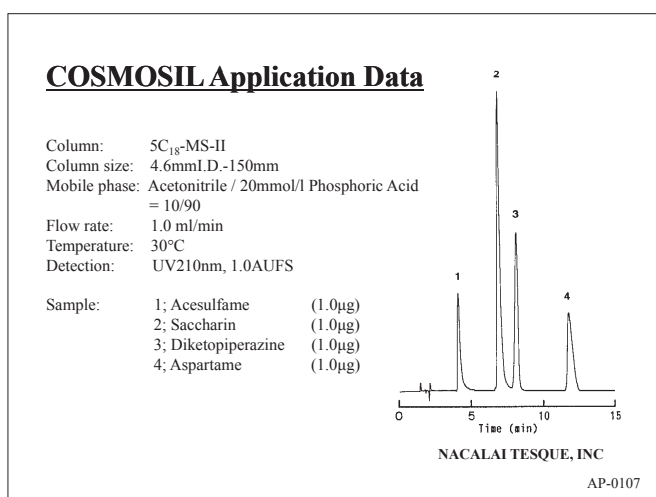

• Synthetic Colorants

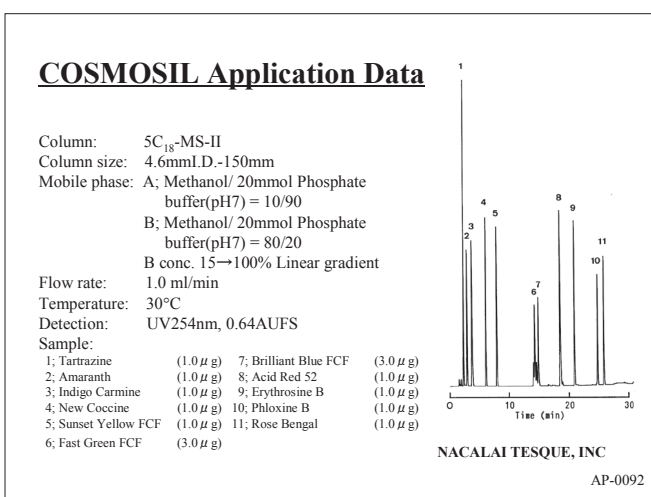

• Synthetic Colorants

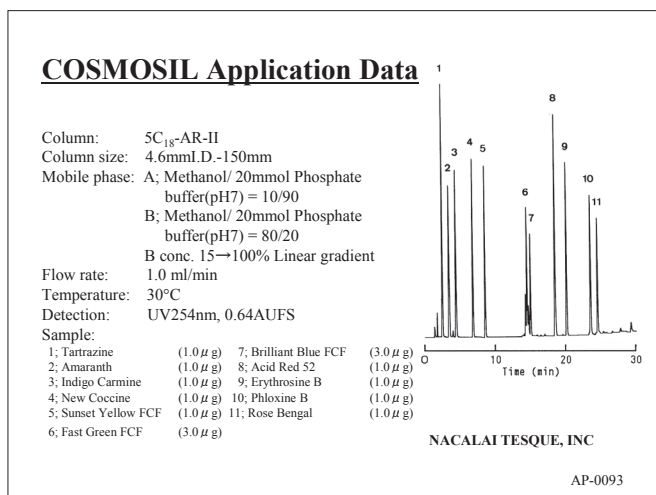

• Food Preservatives

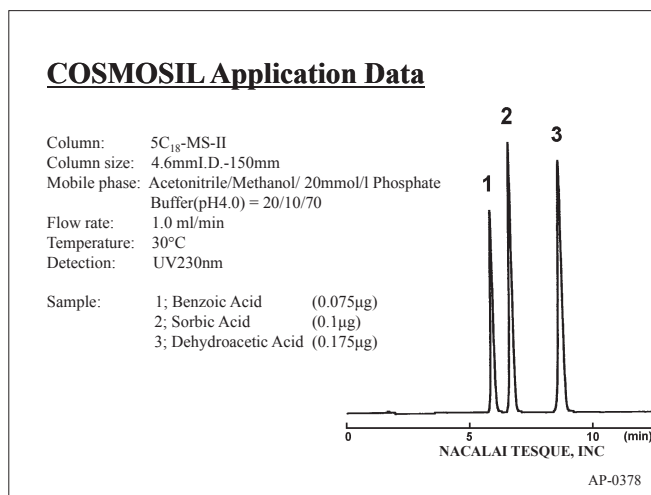

(5) Food Additives

● Preservatives (Fungicides)

COSMOSIL Application Data

Column: 5C₁₈-MS-II
Column size: 4.6mmI.D.-150mm
Mobile phase: Acetonitrile/ H₂O = 60/40
Flow rate: 1.0 ml/min
Temperature: 30°C
Detection: UV230nm, 0.5AUFS

Sample:
1; 2-(4-Thiazolyl)benzimidazole (0.3µg)
2; *o*-Phenylphenol (0.3µg)
3; Imazalil (2.1µg)
4; Biphenyl (0.3µg)

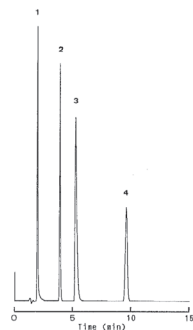

NACALAI TESQUE, INC

AP-0097

● Glycyrrhizic Acid

COSMOSIL Application Data

Column: 5C₁₈-AR-II
Column size: 4.6mmI.D.-150mm
Mobile phase: Acetonitrile / (Acetic Acid/H₂O=1/15)
= 2/3
Flow rate: 1.0 ml/min
Temperature: 30°C
Detection: UV254nm, 0.64AUFS

Sample: 1; Glycyrrhizic Acid [Glycyrrhizin] (5.0µg)
2; *n*-Propyl *p*-Hydroxybenzoate (1.0µg)

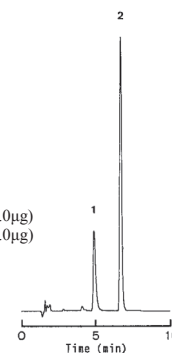

NACALAI TESQUE, INC

AP-0109

● Antioxidants

COSMOSIL Application Data

Column: 5C₁₈-MS-II
Column size: 4.6mmI.D.-150mm
Mobile phase: Methanol / H₂O = 80/20
Flow rate: 1.0 ml/min
Temperature: 30°C
Detection: UV280nm, 0.16AUFS

Sample: 1; *tert*-Butylhydroquinone (0.56µg)
2; 3-*tert*-Butyl-4-hydroxyanisol (0.58µg)
3; 2,6-Di-*t*-butyl-*p*-cresol
[Butylated Hydroxytoluene;BHT](1.85µg)

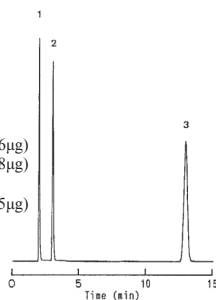

NACALAI TESQUE, INC

AP-0100

● Antioxidants

COSMOSIL Application Data

Column: 5C₁₈-MS-II
Column size: 4.6mmI.D.-150mm
Mobile phase: Methanol / H₂O = 90/10
Flow rate: 1.0 ml/min
Temperature: 30°C
Detection: UV254nm, 0.32AUFS

Sample: 1; *n*-Propyl Gallate (1.0µg)
2; 6-Ethoxy-2,2,4-Trimethyl
-1,2-Dihydroquinoline (1.0µg)

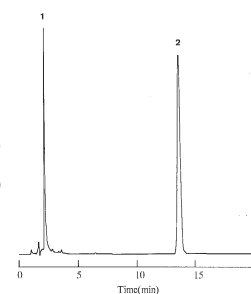

NACALAI TESQUE, INC

AP-0101

● Repellents

COSMOSIL Application Data

Column: 5C₁₈-AR-II
Column size: 4.6mmI.D.-150mm
Mobile phase: Methanol / H₂O = 90/10
Flow rate: 1.0 ml/min
Temperature: 30°C
Detection: UV254nm, 0.32AUFS

Sample: Piperonyl Butoxide (10µg)



NACALAI TESQUE, INC

AP-0104

● Umami Seasonings (Nucleic Acids)

COSMOSIL Application Data

Column: 5C₁₈-AR-II
Column size: 4.6mmI.D.-150mm
Mobile phase: Acetonitrile/ 5mmol/l Tributylammonium
bromide, 20mmol/l Phosphate buffer(pH7)
= 5/95
Flow rate: 1.0 ml/min
Temperature: 30°C
Detection: UV270nm, 0.32AUFS

Sample: 1; Cytidine-5'-monophosphate (1.0µg)
2; Uridine-5'-monophosphate (1.0µg)
3; Guanosine-5'-monophosphate (1.0µg)
4; Inosine-5'-monophosphate (1.0µg)

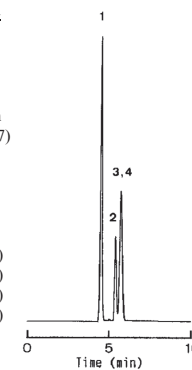

NACALAI TESQUE, INC

AP-0106

(6) Vitamins

• Hydrosoluble Vitamins

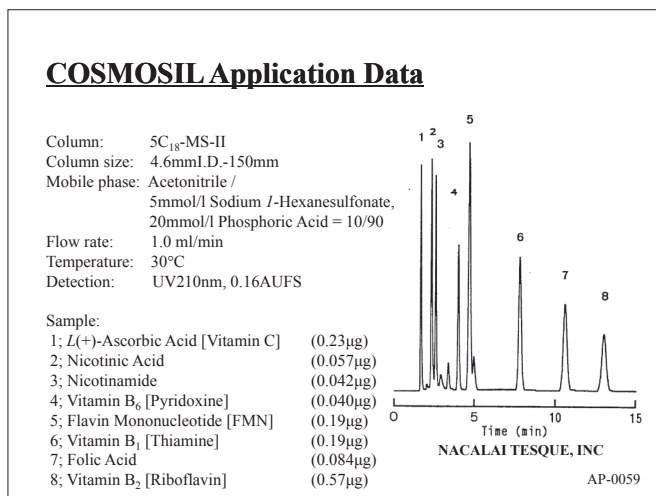

• Hydrosoluble Vitamins

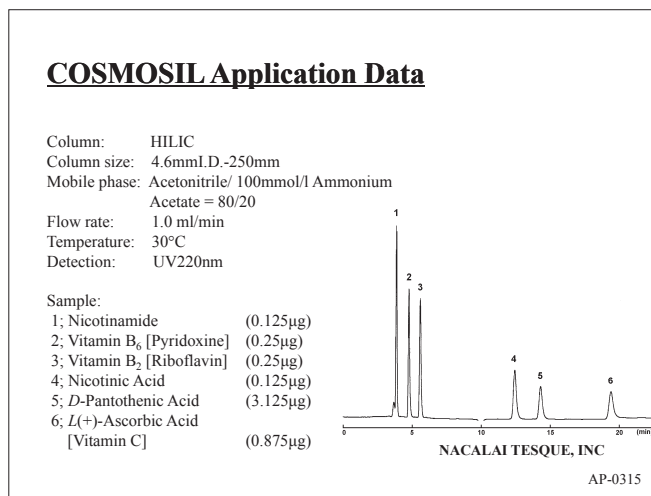

• Water-soluble Vitamins

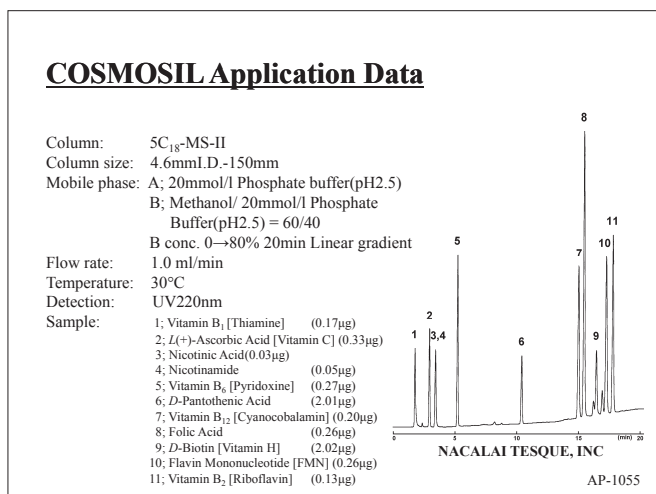

• Ascorbic Acids

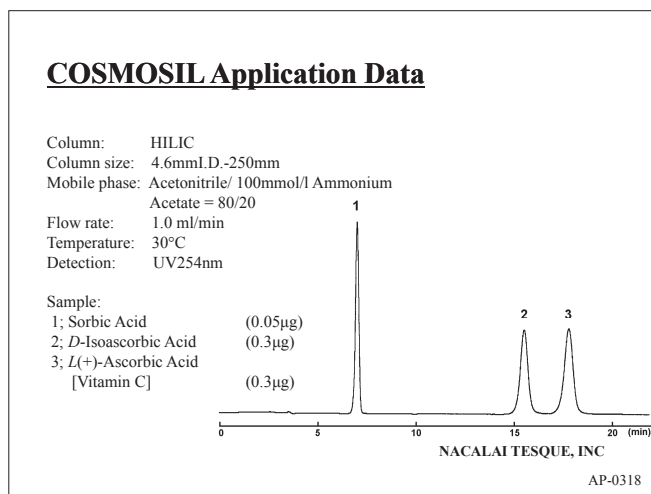

• Energy Drink

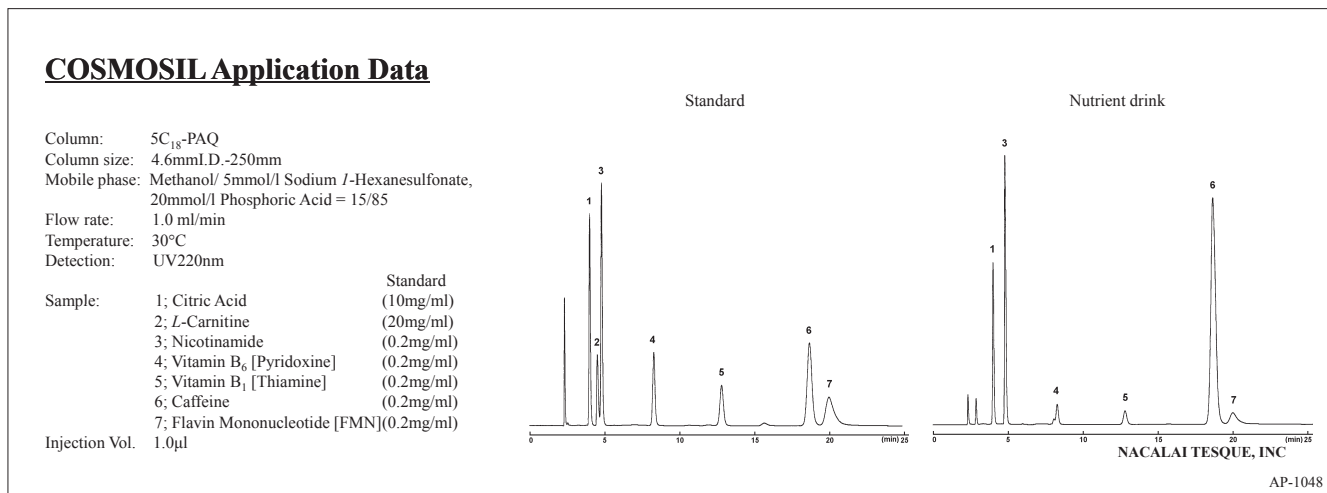

(6) Vitamins

● Fruit Juice

COSMOSIL Application Data

Column: HILIC
Column size: 4.6mm I.D.-250mm
Mobile phase: Acetonitrile/ 10mmol/l Phosphate
Buffer(pH7.0) = 50/50
Flow rate: 1.0 ml/min
Temperature: 30°C
Detection: UV210nm

Sample:
1; L(+)-Ascorbic Acid [Vitamin C] (1.5µg)
2; L(-)-Malic Acid (3.0µg)

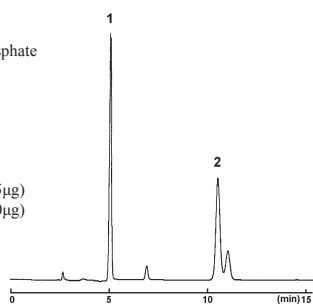

NACALAI TESQUE, INC

AP-0313

● Fat-soluble Vitamins

COSMOSIL Application Data

Column: 5C₁₈-MS-II
Column size: 4.6mm I.D.-150mm
Mobile phase: Acetonitrile/Methanol = 60/40
Flow rate: 1.0 ml/min
Temperature: 30°C
Detection: UV280nm, 0.64AUFS

Sample:
1; Vitamin K₃ (1.71µg)
2; Vitamin A Acetate, all trans (0.44µg)
3; Vitamin D₃ (0.57µg)
4; Vitamin E [DL-α-Tocopherol] (4.97µg)
5; Vitamin E Acetate [DL-α-Tocopherol Acetate] (4.79µg)
6; Vitamin K₁ (1.68µg)

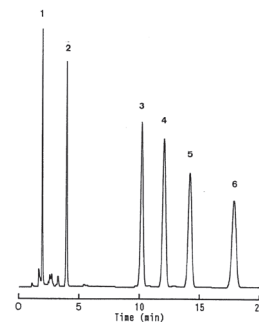

NACALAI TESQUE, INC

AP-0060

● Vitamin D

COSMOSIL Application Data

Column: 5C₁₈-MS-II
Column size: 4.6mm I.D.-150mm
Mobile phase: Methanol
Flow rate: 1.0 ml/min
Temperature: 30°C
Detection: UV265nm

Sample: 1; Vitamin D₂ [Calciferol] (0.3µg)
2; Vitamin D₃ (0.1µg)

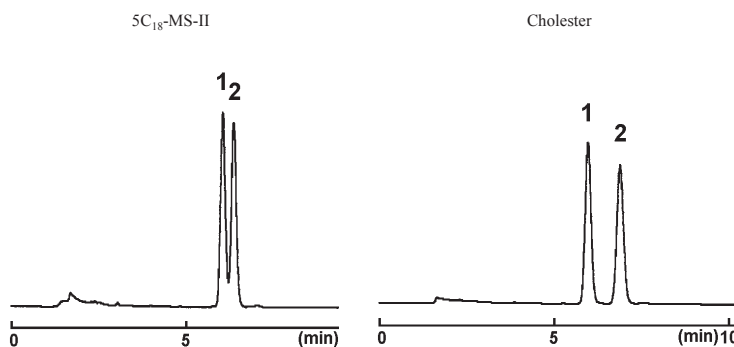

NACALAI TESQUE, INC

AP-1035

● Vitamin E

COSMOSIL Application Data

Column: 5C₁₈-MS-II
Column size: 4.6mm I.D.-250mm
Mobile phase: πNAP Methanol
Methanol/ H₂O = 90/10
Flow rate: 1.0 ml/min
Temperature: 30°C
Detection: UV295nm

Sample:
1; δ-Tocotrienol
2; γ-Tocotrienol
3; β-Tocotrienol
4; α-Tocotrienol
5; δ-Tocopherol
6; γ-Tocopherol
7; β-Tocopherol
8; α-Tocopherol

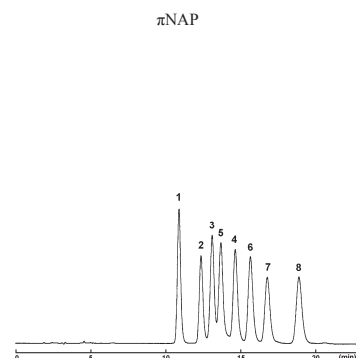
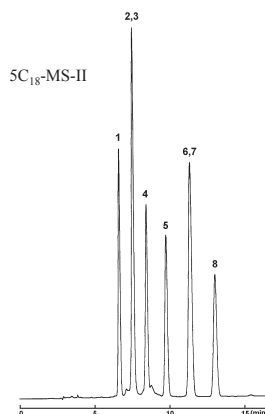

NACALAI TESQUE, INC

AP-1071

(6) Vitamins

• Vitamin E

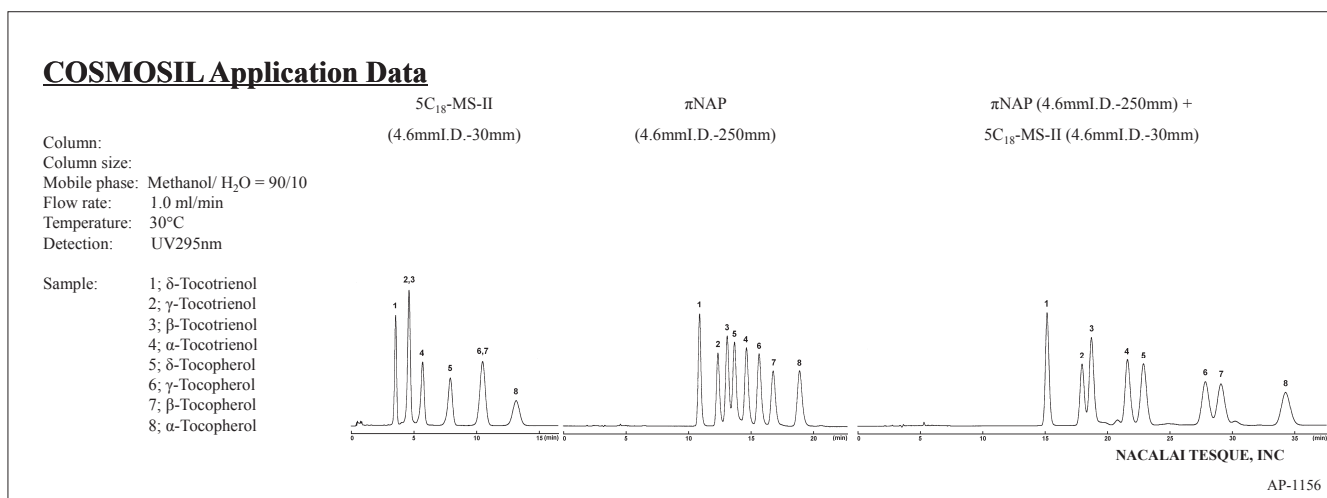

• Vitamin E

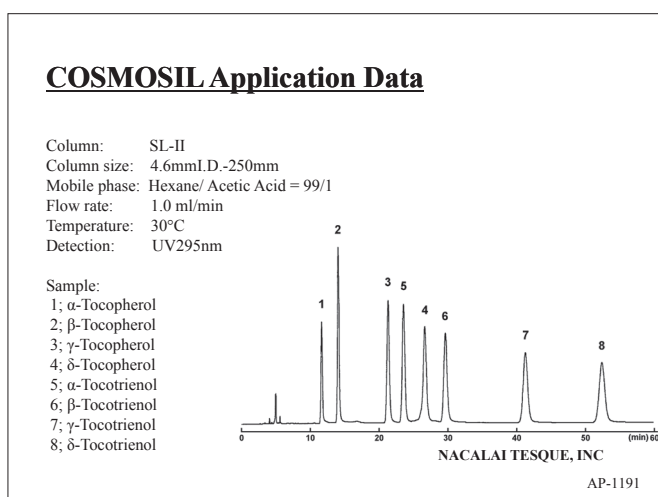

• Vitamin A

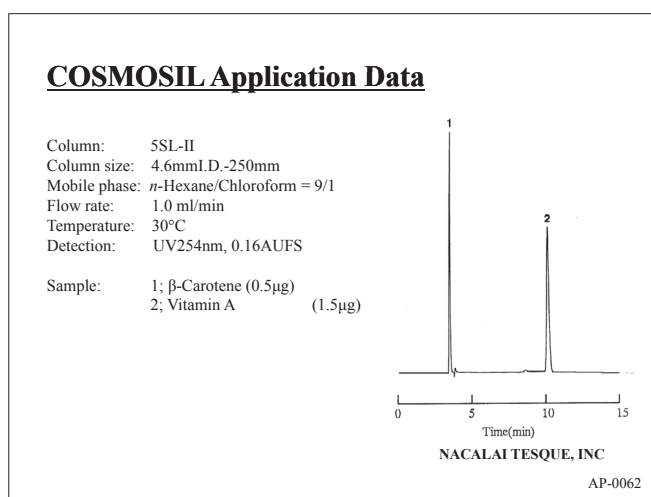

• Vitamin A Acid

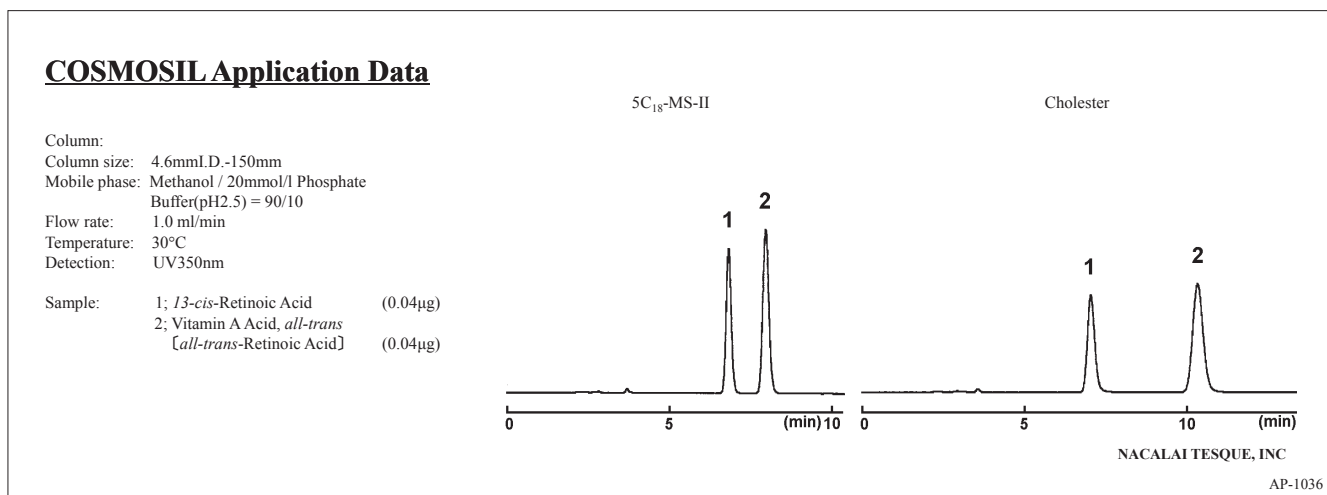

(7) Metabolites

• Androgens

COSMOSIL Application Data

Column: 5C₁₈-AR-II
Column size: 4.6mmI.D.-150mm
Mobile phase: Methanol / H₂O = 70/30
Flow rate: 1.0 ml/min
Temperature: 30°C
Detection: UV235nm, 0.5AUFS

Sample: 1; 4-Androstene-3,17-dione (1.0µg)
2; Testosterone (1.0µg)
3; 17-Methyltestosterone (1.0µg)
4; Testosterone Propionate (1.0µg)

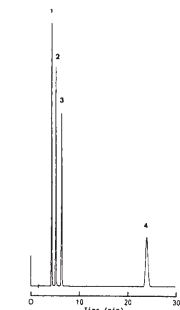

NACALAI TESQUE, INC

AP-0111

• Catecholamines

COSMOSIL Application Data

Column: 5C₁₈-AR-II
Column size: 4.6mmI.D.-150mm
Mobile phase: 20mmol/l NaH₂PO₄
Flow rate: 1.0 ml/min
Temperature: 30°C
Detection: UV270nm, 0.1AUFS

Sample: 1; L-Noradrenaline (1.0µg)
2; (±)-Epinephrine (1.2µg)
3; L-DOPA (1.2µg)
4; Dopamine (1.0µg)
5; 3,4-Dihydroxyphenylacetic Acid (1.0µg)
6; 3-Methoxytyramine (1.0µg)

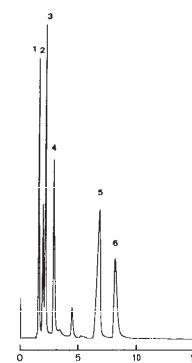

NACALAI TESQUE, INC

AP-0120

• Estrogens

COSMOSIL Application Data

Column: 5C₁₈-AR-II
Column size: 4.6mmI.D.-150mm
Mobile phase: Acetonitrile / H₂O = 35/65
Flow rate: 1.0 ml/min
Temperature: 30°C
Detection: UV280nm, 0.2AUFS

Sample: 1; Estriol (1.5µg)
2; 17β-Estradiol (1.5µg)
3; Estrone (1.5µg)

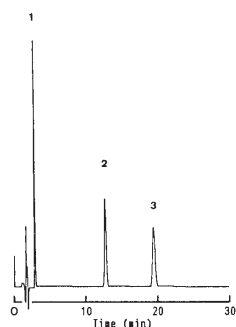

NACALAI TESQUE, INC

AP-0114

• Estradiols

COSMOSIL Application Data

Column: 5C₁₈-MS-II
Column size: 4.6mmI.D.-150mm
Mobile phase: Acetonitrile / H₂O = 40/60
Flow rate: 1.0 ml/min
Temperature: 30°C
Detection: UV280nm

Sample: 1; 17β-Estradiol (2.0µg)
2; 17α-Estradiol (2.0µg)

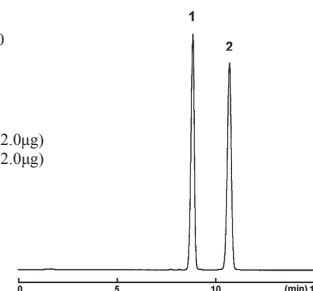

NACALAI TESQUE, INC

AP-0243

• Hippuric Acids

COSMOSIL Application Data

Column: 5C₁₈-MS-II
Column size: 4.6mmI.D.-150mm
Mobile phase: Methanol/ 20mmol/l Phosphate
Buffer(pH3) = 15/85
Flow rate: 1.0 ml/min
Temperature: 30°C
Detection: UV225nm, 0.32AUFS

Sample: 1; Creatinine (0.14µg)
2; Mandelic Acid (1.89µg)
3; Hippuric Acid (0.61µg)
4; N-(o-Toluoyl)glycine (0.52µg)

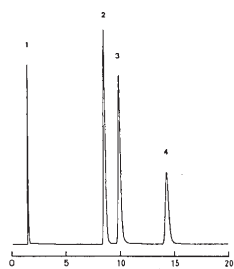

NACALAI TESQUE, INC

AP-0112

• Methylhippuric Acids

COSMOSIL Application Data

Column: 5PYE
Column size: 4.6mmI.D.-250mm
Mobile phase: Methanol/ 20mmol/l Phosphate
buffer(pH2.5) = 40/60
Flow rate: 1.0 ml/min
Temperature: 30°C
Detection: UV254nm

Sample: N-(o-Toluoyl)glycine (3.06µg)
N-(m-Toluoyl)glycine (0.65µg)
N-(p-Toluoyl)glycine (0.33µg)

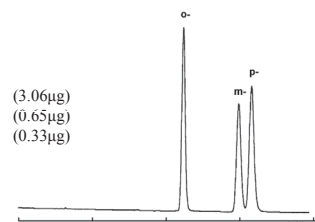

NACALAI TESQUE, INC

AP-0289

● Urate Metabolites

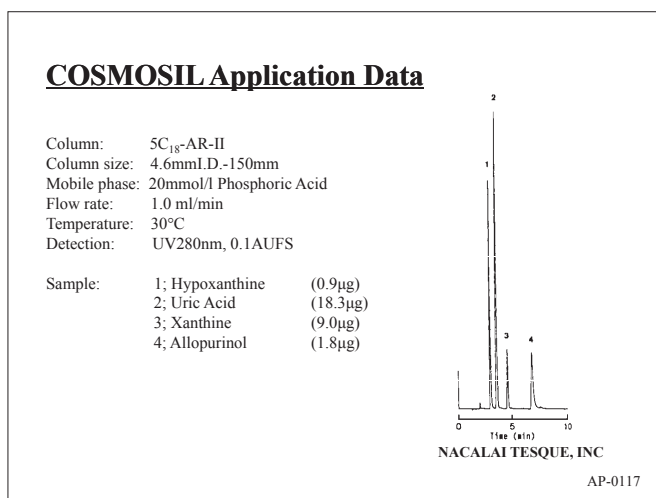

● Prostaglandins

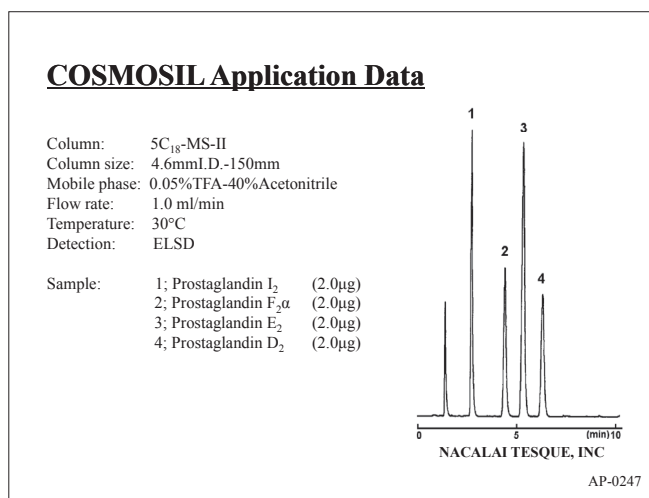

● Adrenal Cortical Hormones

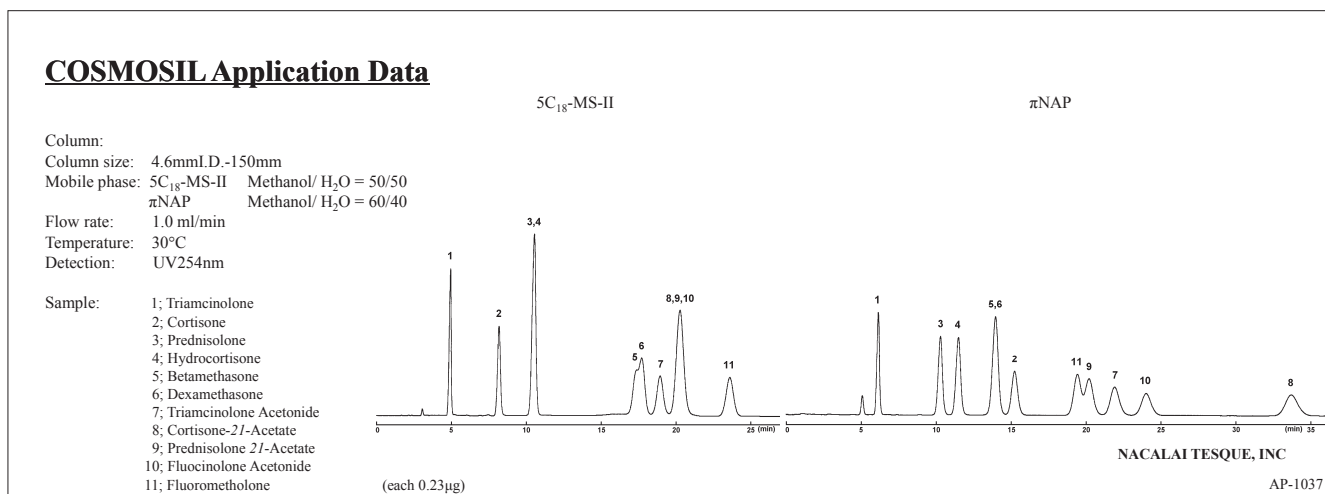

● Adrenal Cortical Hormones

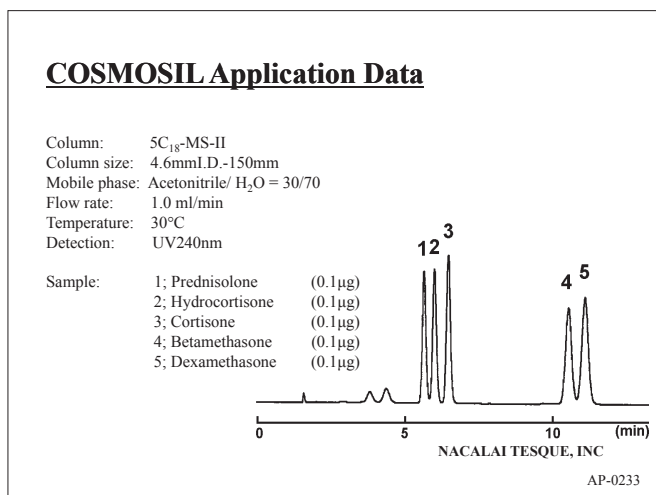

● Adrenal Cortical Hormones

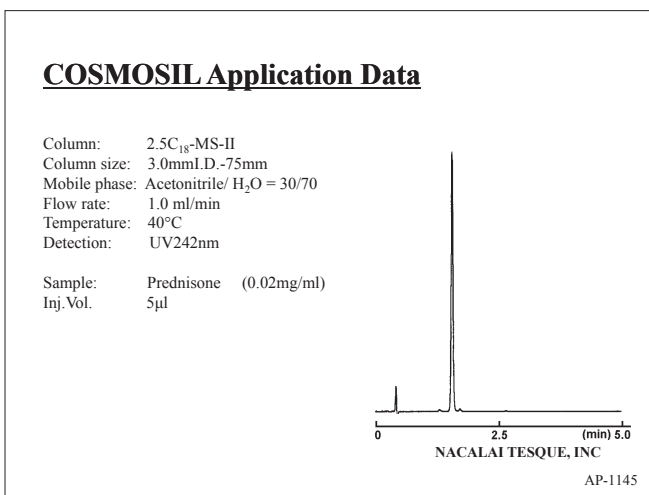

(8) Carbohydrates

● Oligosaccharides

COSMOSIL Application Data

Column: Sugar-D
Column size: 4.6mmI.D.-250mm
Mobile phase: Acetonitrile / H₂O = 75/25
Flow rate: 1.0 ml/min
Temperature: 30°C
Detection: RI

Sample:
1; Sucrose (10µg)
2; Maltose (10µg)
3; D-(+)- Trehalose (10µg)
4; D-(+)- Raffinose (10µg)

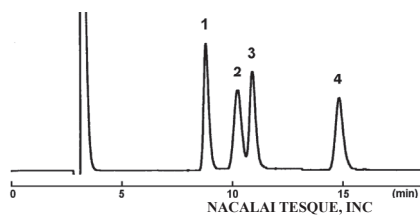

● Cyclodextrins

COSMOSIL Application Data

Column: Sugar-D
Column size: 4.6mmI.D.-250mm
Mobile phase: Acetonitrile / H₂O = 65/35
Flow rate: 1.0 ml/min
Temperature: 30°C
Detection: RI

Sample: 1; α-Cyclodextrin (10µg)
2; β-Cyclodextrin (10µg)
3; γ-Cyclodextrin (10µg)

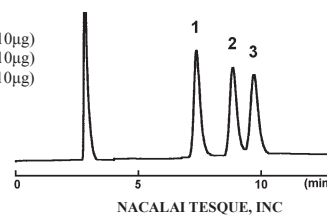

● Xylooligosaccharides

COSMOSIL Application Data

Column: Sugar-D
Column size: 4.6mmI.D.-250mm
Mobile phase: Acetonitrile / H₂O = 75/25
Flow rate: 1.0 ml/min
Temperature: 30°C
Detection: RI

Sample: Xylooligosaccharides (50µg)
(Xylobiose, Xylotriose etc.)

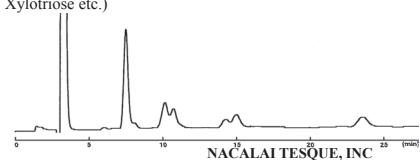

● Isomaltooligosaccharides

COSMOSIL Application Data

Column: Sugar-D
Column size: 4.6mmI.D.-250mm
Mobile phase: Acetonitrile / H₂O = 75/25
Flow rate: 1.0 ml/min
Temperature: 30°C
Detection: RI

Sample: Isomaltooligosaccharides (50µg)
(Isomaltose, Isomaltotriose, Panose etc.)

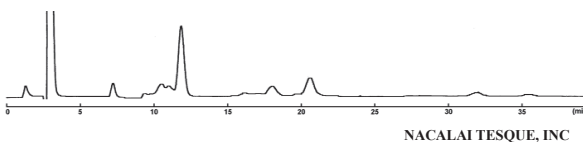

● Anticariious Foods Components

COSMOSIL Application Data

Column: Sugar-D
Column size: 4.6mmI.D.-250mm
Mobile phase: Acetonitrile / H₂O = 75/25
Flow rate: 1.0 ml/min
Temperature: 30°C
Detection: RI

Sample:
1; meso-Erythritol [meso-Erythrite] (10µg)
2; Xylitol (10µg)
3; Palatinose (10µg)
4; Maltitol (10µg)

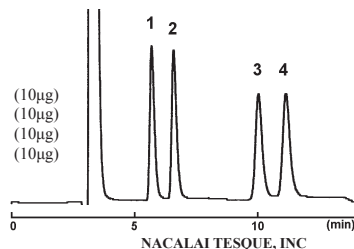

● Infusion Solution Components

COSMOSIL Application Data

Column: Sugar-D
Column size: 4.6mmI.D.-250mm
Mobile phase: Acetonitrile / H₂O = 85/15
Flow rate: 1.0 ml/min
Temperature: 50°C
Detection: RI

Sample: 1; Xylitol (10µg)
2; D-(-)-Fructose (10µg)
3; D-(+)-Glucose (10µg)

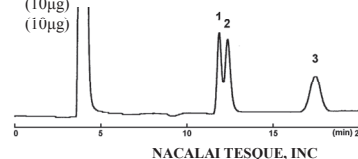

(8) Carbohydrates

• Energy Drink

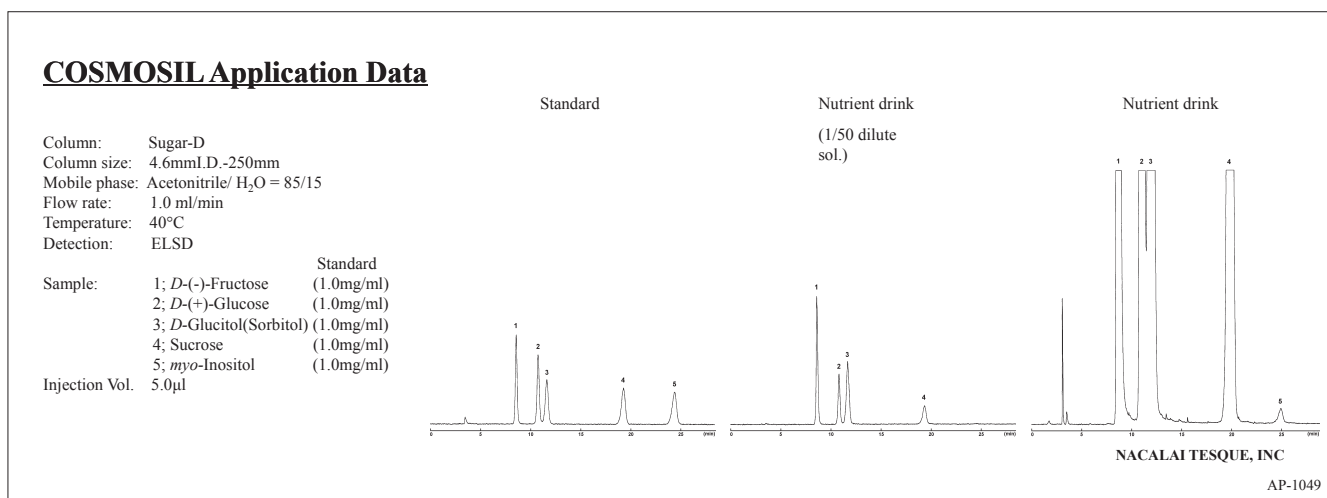

• Chocolate Components

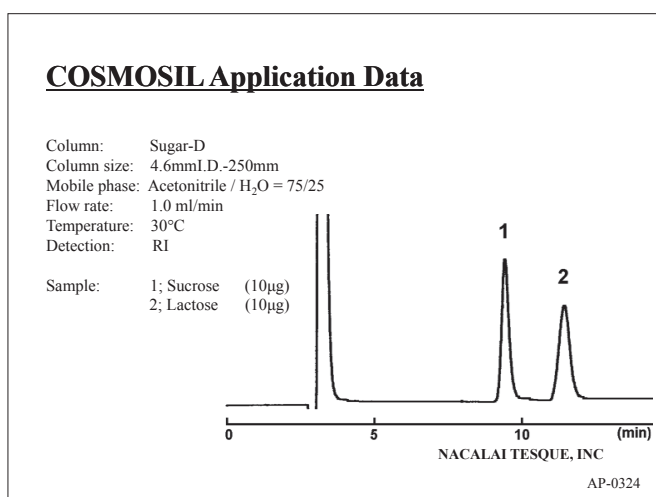

• Gum Components

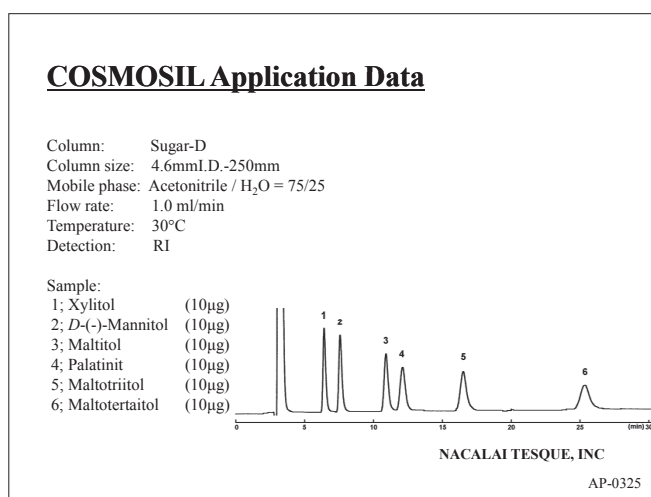

• Cold Beverage Components

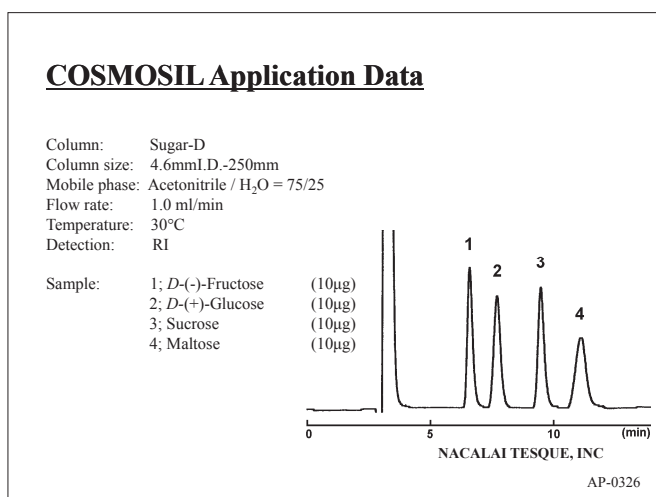

• Sports Drink Components

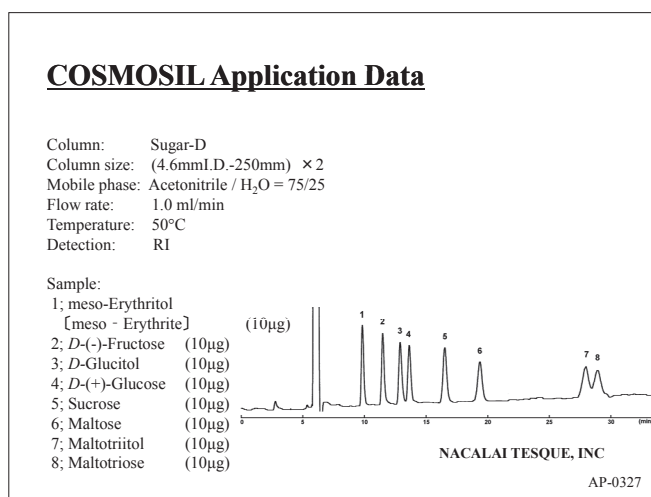

(8) Carbohydrates

● PA-Glucose Oligomer

COSMOSIL Application Data

Column: 5C₁₈-PAQ
Column size: 4.6mmI.D.-150mm
Mobile phase: A: 20mmol/l Acetate Buffer(pH3.3)
B: 20mmol/l Acetate Buffer(pH3.3)+0.5%Butanol
B(0→100%) 45min Linear gradient

Flow rate: 1.0 ml/min
Temperature: 30°C
Detection: FLS at Ex.320nm
Em. 400nm

Sample:
PA-Glucose Oligomer(DP=3-22)

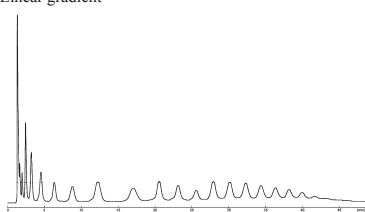

NACALAI TESQUE, INC

AP-0379

● Phosphorylated Sugars

COSMOSIL Application Data

Column: HILIC
Column size: 4.6mmI.D.-250mm
Mobile phase: Acetonitrile/ 20mmol/l Phosphate
Buffer(pH7.0) = 60/40

Flow rate: 1.0 ml/min
Temperature: 30°C
Detection: RI

Sample:
1; D-Fructose-6-phosphate (50µg)
2; D-Glucose-6-phosphate (50µg)

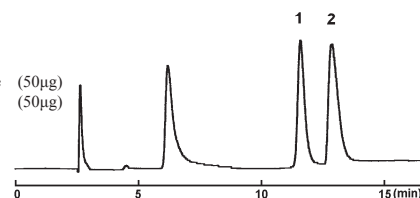

NACALAI TESQUE, INC

AP-0317

● Phosphorylated Sugars

COSMOSIL Application Data

Column: HILIC
Column size: 4.6mmI.D.-250mm
Mobile phase: Acetonitrile/ 20mmol/l Phosphate
Buffer(pH7.0) = 60/40

Flow rate: 1.0 ml/min
Temperature: 30°C
Detection: RI

Sample:
1; D-(+)-Glucose (10µg)
2; α-D-Glucose-1-phosphate (50µg)
3; D-Glucose-6-phosphate (50µg)

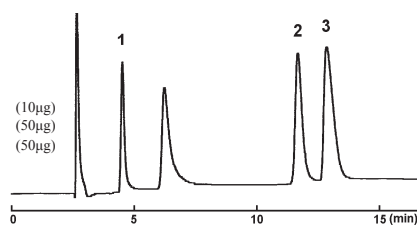

NACALAI TESQUE, INC

AP-0314

● Hyaluronic Acid

COSMOSIL Application Data

Column: CNT-1000
Column size: 7.5mmI.D.-300mm
Mobile phase: 20mmol/l Phosphate Buffer(pH7),100mmol/l Na₂SO₄

Flow rate: 1.0 ml/min
Temperature: 30°C
Detection: RI

Sample: Hyaluronic Acid (100µg)

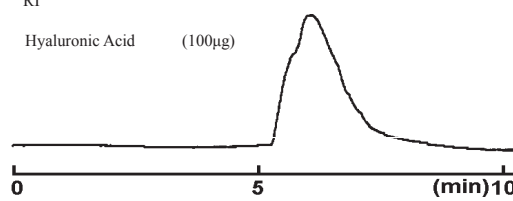

NACALAI TESQUE, INC

AP-1081

● Enzyme digests of Chondroitin Sulfate A

COSMOSIL Application Data

Column: Cholester
Column size: 4.6mmI.D.-150mm
Mobile phase: A: 1mmol/l Tetrabutylammonium Bisulfate/H₂O
B: 1mmol/l Tetrabutylammonium Bisulfate
-Acetonitrile/H₂O=67/33
B conc. 20%→65%(7min)→65%(12min)

Flow rate: 1.0 ml/min
Temperature: 40°C
Detection: UV240nm

Sample: Chondroitin Sulfate A
Chodrotinase AC-II digested

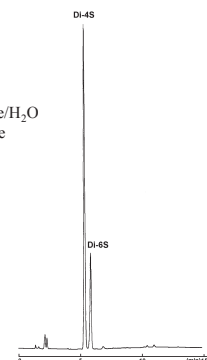

NACALAI TESQUE, INC

AP-1082

● Enzyme digests of Chondroitin Sulfate C

COSMOSIL Application Data

Column: Cholester
Column size: 4.6mmI.D.-150mm
Mobile phase: A: 1mmol/l Tetrabutylammonium Bisulfate/H₂O
B: 1mmol/l Tetrabutylammonium Bisulfate
-Acetonitrile/H₂O=67/33
B conc. 20%→65%(7min)→65%(12min)

Flow rate: 1.0 ml/min
Temperature: 40°C
Detection: UV240nm

Sample: Chondroitin Sulfate C
Chodrotinase AC-II digested

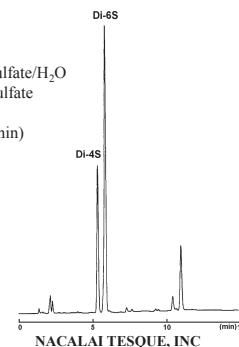

NACALAI TESQUE, INC

AP-1083

(9) Lipids

● Fatty Acids

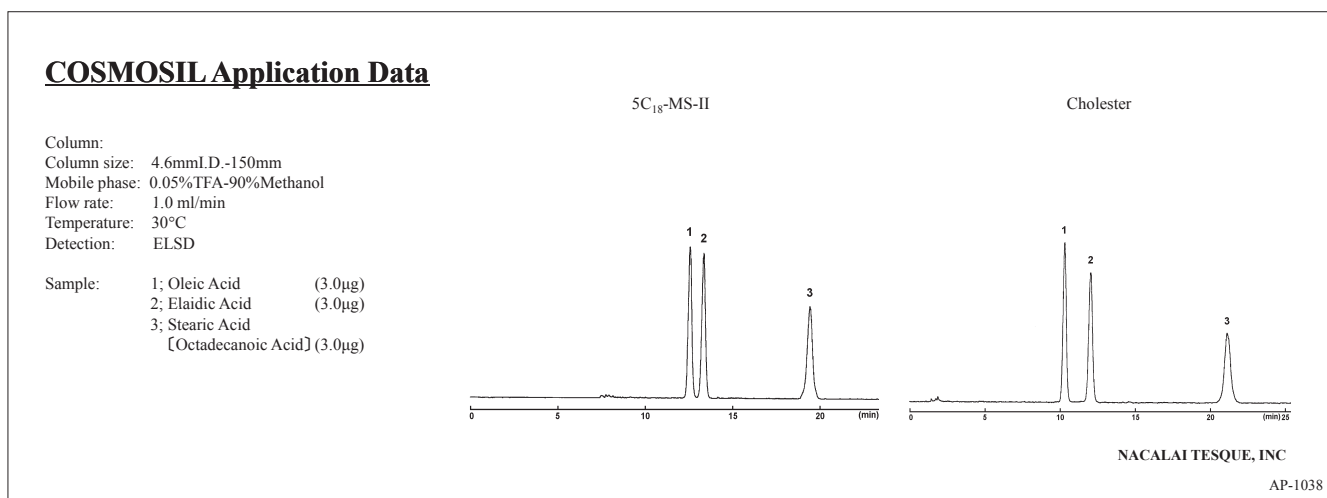

● Fatty Acids

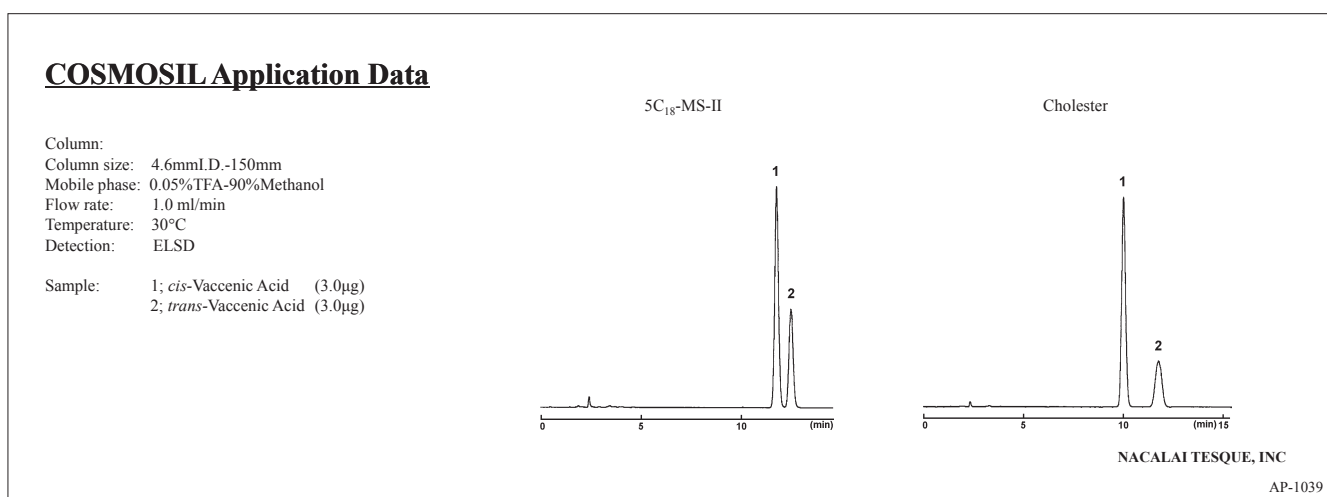

● Methylated Fatty Acids

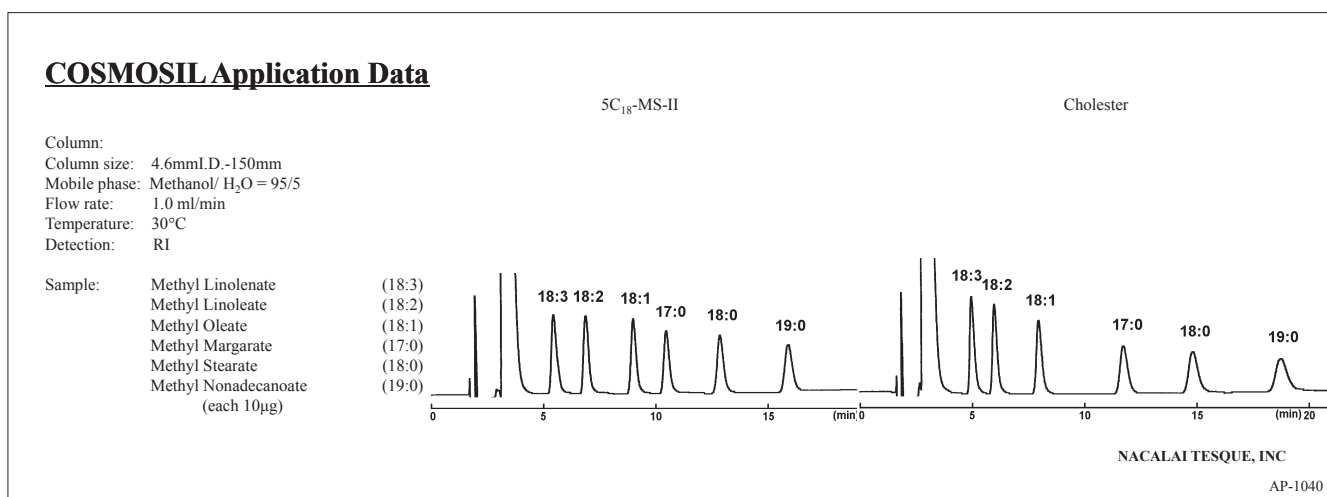

(9) Lipids

● Fatty Acid Derivatives

COSMOSIL Application Data

Column: Cholesterol
Column size: 4.6mm I.D.-250mm
Mobile phase: Methanol/ H₂O = 90/10
Flow rate: 1.0 ml/min
Temperature: 30°C
Detection: UV254nm

Sample: 1; Linolenic Acid *p*-Bromophenacyl Ester
2; γ -Linolenic Acid *p*-Bromophenacyl Ester

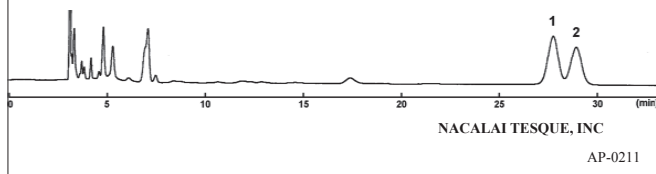

● Phosphatides

COSMOSIL Application Data

Column: 5SL-II
Column size: 4.6mm I.D.-250mm
Mobile phase: 0.05%TFA-Methanol
Flow rate: 1.0 ml/min
Temperature: 30°C
Detection: ELSD

Sample: *L*- α -Phosphatidyl Choline (10 μ g)

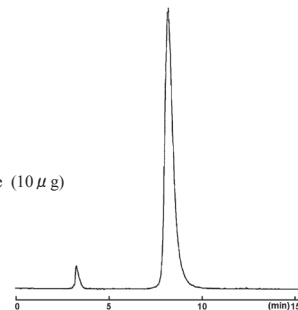

● Phosphatides

COSMOSIL Application Data

Column: 5C₁₈-MS-II
Column size: 4.6mm I.D.-250mm
Mobile phase: 0.05%TFA-10%THF/90%Methanol
Flow rate: 1.0 ml/min
Temperature: 30°C
Detection: ELSD

Sample: *L*- α -Phosphatidyl Choline (2.0 μ g)

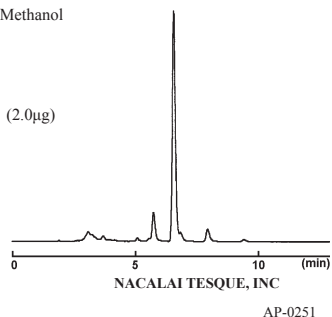

● Phosphatides

COSMOSIL Application Data

Column: 5C₁₈-MS-II
Column size: 4.6mm I.D.-250mm
Mobile phase: 0.05%TFA-10%THF/90%Methanol
Flow rate: 1.0 ml/min
Temperature: 30°C
Detection: ELSD

Sample: *L*- α -Phosphatidyl-L-serine

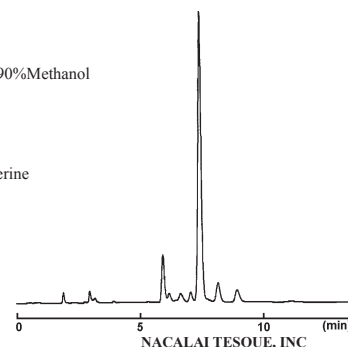

● Phosphatides

COSMOSIL Application Data

Column: 5C₁₈-MS-II
Column size: 4.6mm I.D.-250mm
Mobile phase: 0.05%TFA-10%THF/90%Methanol
Flow rate: 1.0 ml/min
Temperature: 30°C
Detection: ELSD

Sample: *L*- α -Phosphatidylethanolamine (8.0 μ g)

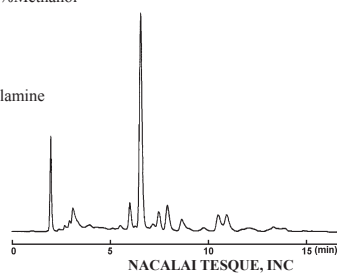

● Phosphatides

COSMOSIL Application Data

Column: 5C₁₈-MS-II
Column size: 4.6mm I.D.-250mm
Mobile phase: 0.05%TFA-10%THF/90%Methanol
Flow rate: 1.0 ml/min
Temperature: 30°C
Detection: ELSD

Sample: *L*- α -Phosphatidylinositol Sodium Salt

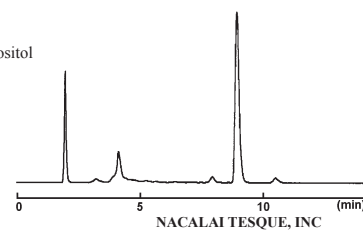

● Nucleobases and Nucleosides

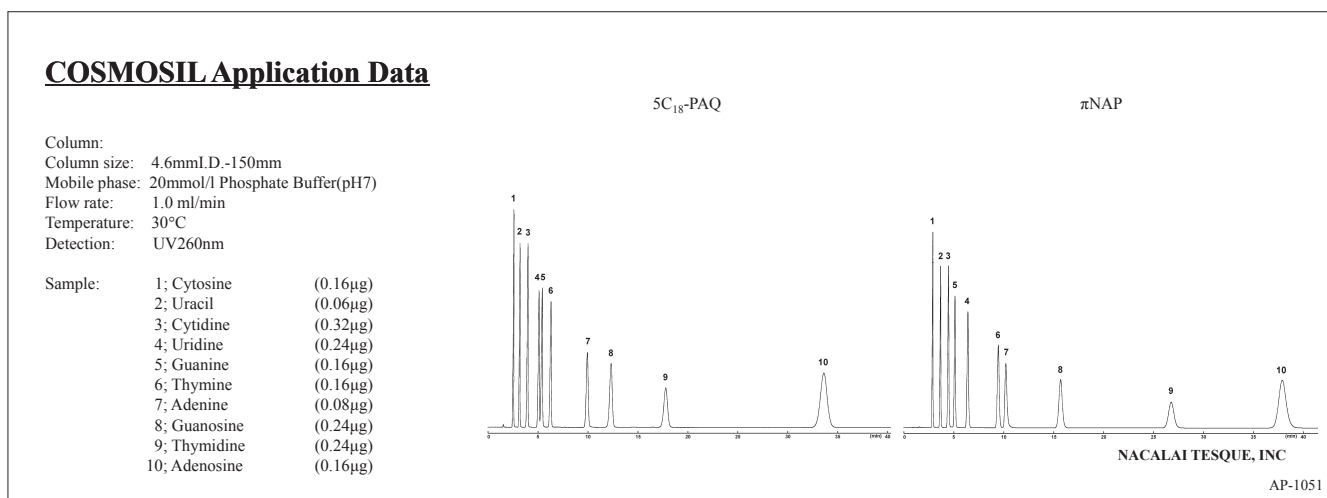

● Nucleobases and Nucleosides

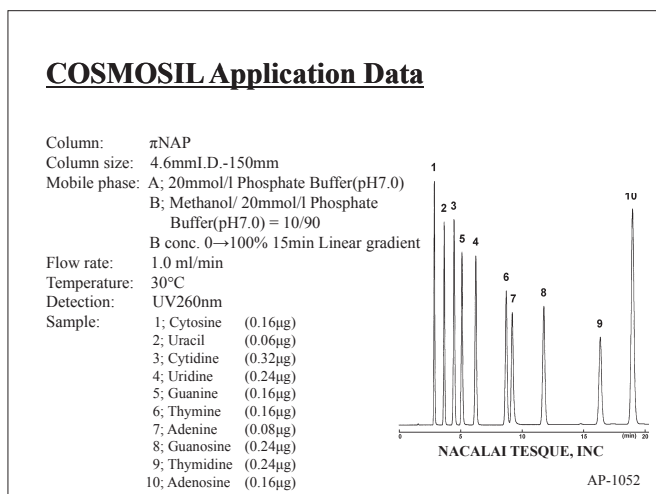

● Nucleobases, Nucleosides and Nucleotides

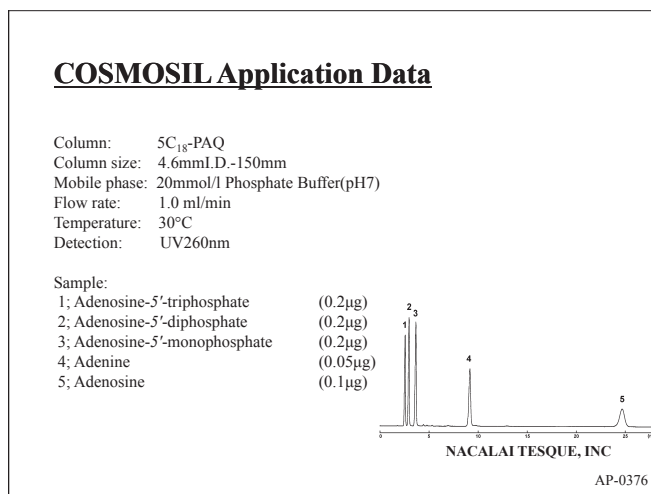

● Nucleotides

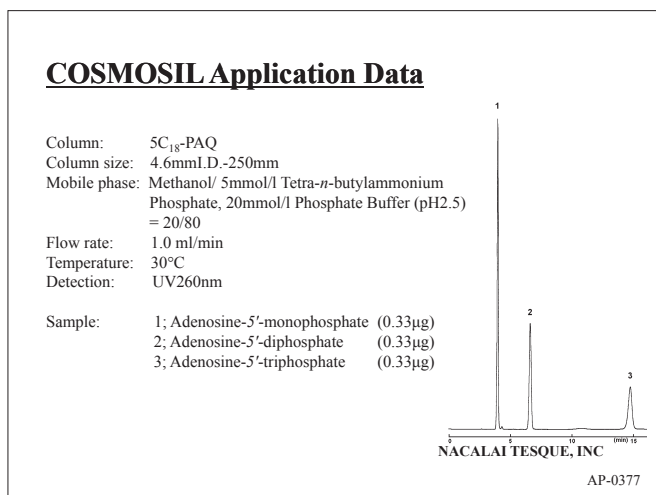

● Nucleotides

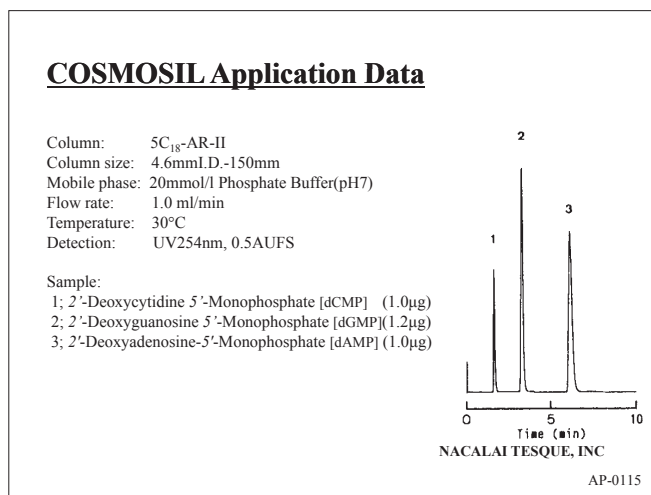

(10) Nucleic Acid Related Substances

● Oligonucleotide

COSMOSIL Application Data

Column: Protein-R
Column size: 4.6mm I.D.-150mm
Mobile phase: A: 100mmol/l Ammonium Acetate
B: Acetonitrile
B conc. 9→11% 15min Linear gradient
Flow rate: 1.0 ml/min
Temperature: 30°C
Detection: UV260nm

Sample: pd(T)₁₂₋₁₈

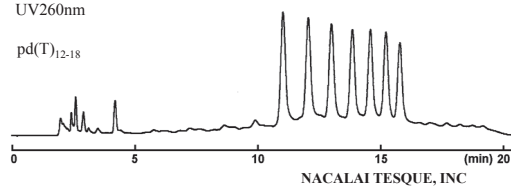

● Oligonucleotide

COSMOSIL Application Data

Column: COSMOGEL IEX Type Q-N
Column size: 4.6mm I.D.-100mm
Mobile phase: A: 20mmol/l Tris Buffer(pH8.3)
B: 20mmol/l Tris Buffer(pH8.3)
+ 1.0mol/l NaCl
B conc. 50→60% 30min Linear gradient
Flow rate: 0.5 ml/min
Temperature: 30°C
Detection: UV260nm

Sample: DNA [pd(A)₄₀₋₆₀]

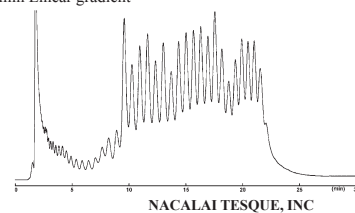

● DNA Ladder

COSMOSIL Application Data

Column: COSMOGEL IEX Type Q-N
Column size: 4.6mm I.D.-100mm
Mobile phase: A: 20mmol/l Tris Buffer(pH8.3)
B: 20mmol/l Tris Buffer(pH8.3)
+ 1.0mol/l NaCl
B conc. 75→85% 30min Linear gradient
Flow rate: 0.5 ml/min
Temperature: 30°C
Detection: UV260nm

Sample: DNA (100b.p. Ladder)

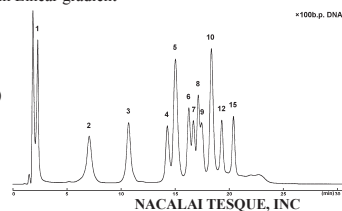

● DNA Ladder

COSMOSIL Application Data

Column: CNT-1000 + CNT-2000
Column size: 7.5mm I.D.-300mm × 2
Mobile phase: 20mmol/l Phosphate Buffer(pH7), 100mmol/l Na₂SO₄
Flow rate: 1.0 ml/min
Temperature: 30°C
Detection: UV260nm

Sample: DNA (100b.p. Ladder)

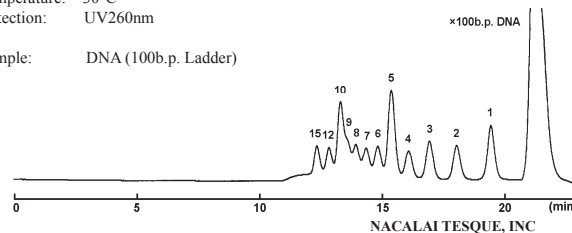

● λDNA/Hind III digest

COSMOSIL Application Data

Column: COSMOGEL IEX Type Q-N
Column size: 4.6mm I.D.-100mm
Mobile phase: A: 20mmol/l Tris buffer(pH8.3)
B: 20mmol/l Tris buffer(pH8.3)
+ 1.0mol/l NaCl
B conc. 75→85% 30min Linear gradient
Flow rate: 0.5 ml/min
Temperature: 30°C
Detection: UV260nm

Sample: DNA (λ/Hind III digest)

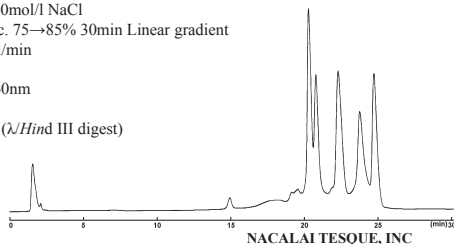

● λDNA/Hind III digest-ØX174/Hinc II digest

COSMOSIL Application Data

Column: COSMOGEL IEX Type Q-N
Column size: 4.6mm I.D.-100mm
Mobile phase: A: 20mmol/l Tris buffer(pH8.3)
B: 20mmol/l Tris buffer(pH8.3)
+ 1.0mol/l NaCl
B conc. 75→85% 30min Linear gradient
Flow rate: 0.5 ml/min
Temperature: 30°C
Detection: UV260nm

Sample: DNA (λ/Hind III digest
- φX174/Hinc II digest)

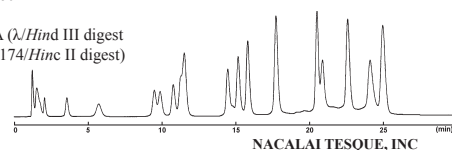

• Dansyl Amino Acids

COSMOSIL Application Data

Column: 5C₁₈-MS-II
 Column size: 4.6mmI.D.-150mm
 Mobile phase: A; Acetonitrile/ 20mmol Phosphate buffer(pH7.0) =10/90
 B; Acetonitrile/ 20mmol Phosphate buffer(pH7.0) =40/60
 B conc. 0→100% 30min Linear gradient
 Flow rate: 1.0 ml/min
 Temperature: 30°C
 Detection: Ex.365nm Em.530nm RANGE 2
 Sample: Dansyl Amino Acids (1.0 μg each)

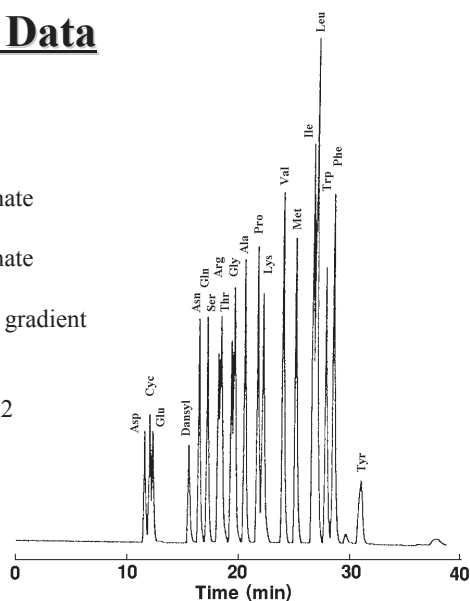

NACALAI TESQUE, INC

AP-0003

• PTH-Amino Acids

COSMOSIL Application Data

Column: 5C₁₈-AR-II
 Column size: 4.6mmI.D.-150mm
 Mobile phase: A; Acetonitrile/ 20mmol/l Acetate buffer(pH4.8) =10/90
 B; Acetonitrile/ 20mmol/l Acetate buffer(pH4.8) =50/50
 Step wise gradient
 Flow rate: 1.0 ml/min
 Temperature: 60°C
 Detection: UV270nm, 0.16AUFS
 Sample: PTH-Asp (0.4mg/ml)
 PTH-His (0.3mg/ml)
 PTH-Arg (0.5mg/ml)
 PTH-Ser (0.3mg/ml)
 PTH-Trp (0.25mg/ml)
 PTH-Lys (0.35mg/ml)
 Others (0.2mg/ml)
 Injection 2.0 μl

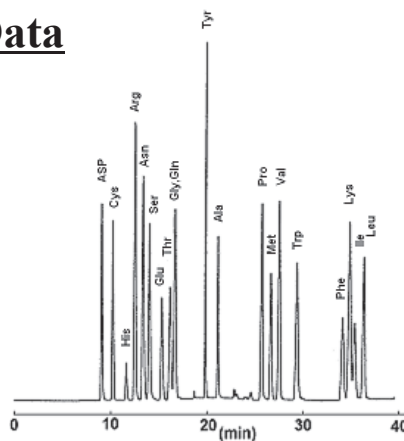

Time (min)	B Conc.(%)
0	0
2.5	0
12.5	15
15	70
30	80
35	100
40	100

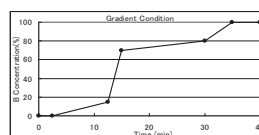

NACALAI TESQUE, INC

AP-0004

● Amino-Acid Derivatives (Diastereomer)

COSMOSIL Application Data

Column: 5C₁₈-MS-II
Column size: 4.6mmI.D.-150mm
Mobile phase: Methanol/ H₂O = 70/30
Flow rate: 1.0 ml/min
Temperature: 30°C
Detection: UV254nm

Sample: 1; Boc-(L)Phe-(L)Phe-OMe (7.5µg)
2; Boc-(D)Phe-(L)Phe-OMe (7.5µg)

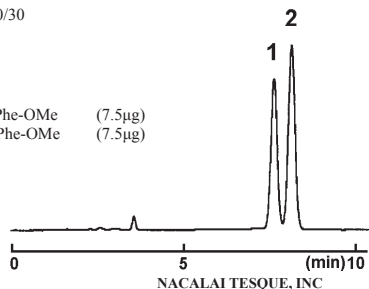

NACALAI TESQUE, INC

AP-0241

● The umami of Vesitables

COSMOSIL Application Data

Column: 5C₁₈-PAQ
Column size: 4.6mmI.D.-250mm
Mobile phase: 5mmol/l Sodium L-Hexanesulfonate,
20mmol/l Phosphoric Acid
Flow rate: 1.0 ml/min
Temperature: 30°C
Detection: UV210nm

Sample: 1; L-Aspartic Acid (10µg)
2; L-Glutamic Acid (10µg)
3; γ-Amino-n-butyric Acid [GABA] (20µg)

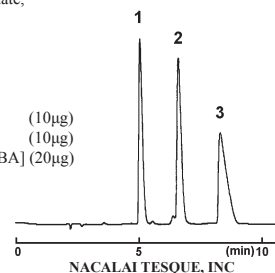

NACALAI TESQUE, INC

AP-1015

● Energy Drink

COSMOSIL Application Data

Column: HILIC
Column size: 4.6mmI.D.-250mm
Mobile phase: Acetonitrile/ 10mmol/l
Ammonium Acetate = 80/20
Flow rate: 1.0 ml/min
Temperature: 30°C
Detection: ELSD

Sample: 1; Taurine (10mg/ml)
Injection Vol. 0.5µl

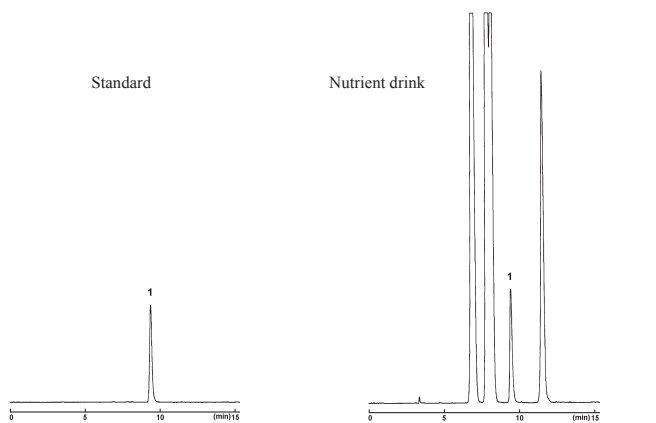

NACALAI TESQUE, INC

AP-1050

● Peptides

COSMOSIL Application Data

Column: Protein-R
Column size: 4.6mmI.D.-150mm
Mobile phase: A; 0.05%TFA-H₂O
B; 0.05%TFA-Acetonitrile
B conc. 10→40% 20min Linear gradient
Flow rate: 1.0 ml/min
Temperature: 30°C
Detection: UV220nm

Sample: 1; Oxytocin (0.8µg)
2; Angiotensin II(Human) (0.8µg)
3; Angiotensin I(Human) (0.8µg)
4; Substance P (0.8µg)

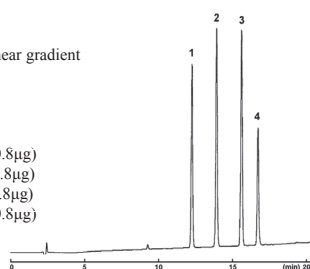

NACALAI TESQUE, INC

AP-0350

● Peptides

COSMOSIL Application Data

Column: Cholestel
Column size: 4.6mmI.D.-150mm
Mobile phase: A; 0.05%TFA-H₂O
B; 0.05%TFA-Acetonitrile
B conc. 10→40% 20min Linear gradient
Flow rate: 1.0 ml/min
Temperature: 30°C
Detection: UV220nm

Sample: 1; Oxytocin (0.8µg)
2; Angiotensin II(Human) (0.8µg)
3; Angiotensin I(Human) (0.8µg)
4; Substance P (0.8µg)

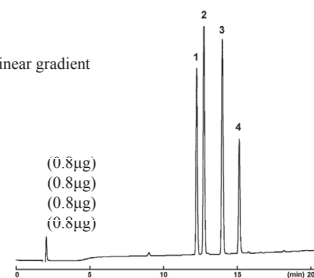

NACALAI TESQUE, INC

AP-0238

● Peptides

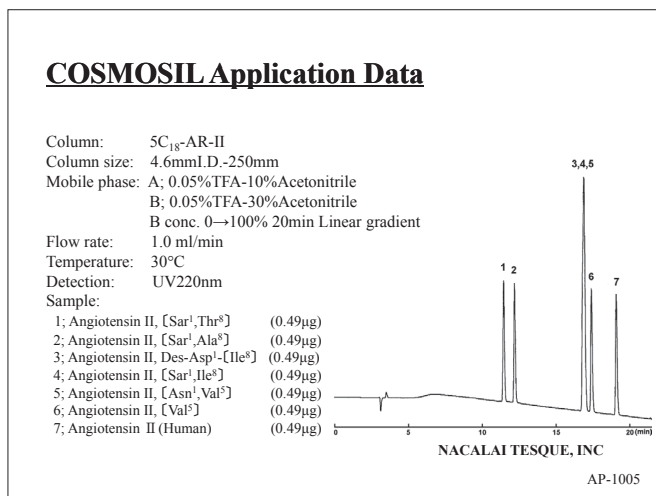

● Peptides

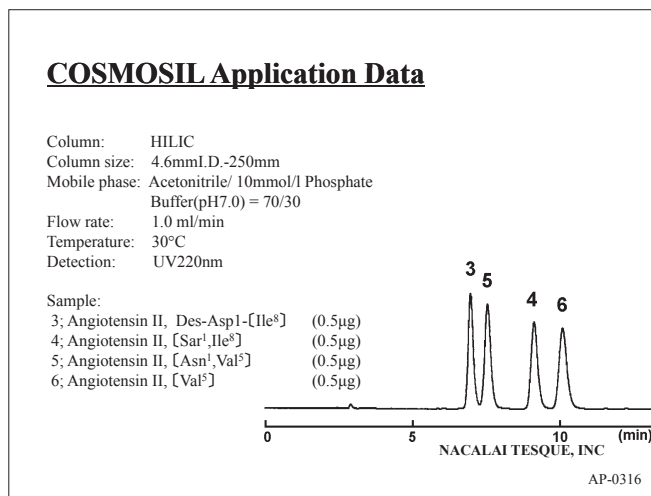

● Peptides

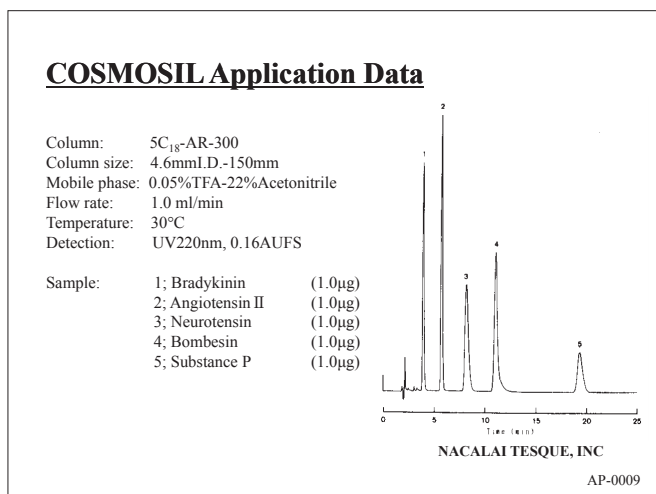

● Peptides

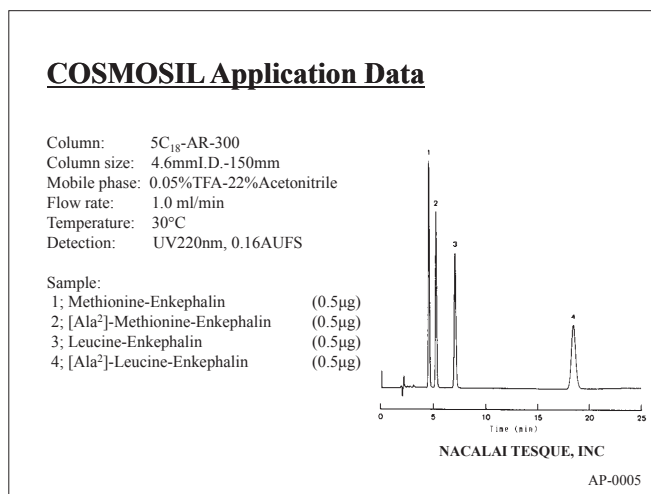

● Peptide Mappings

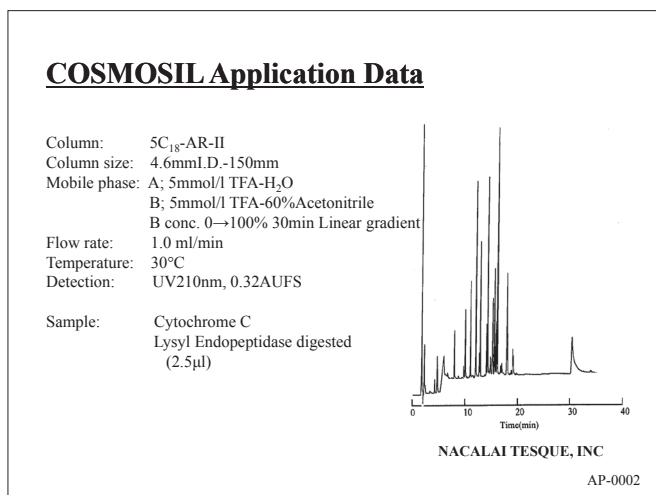

● Semi-purified Myosin

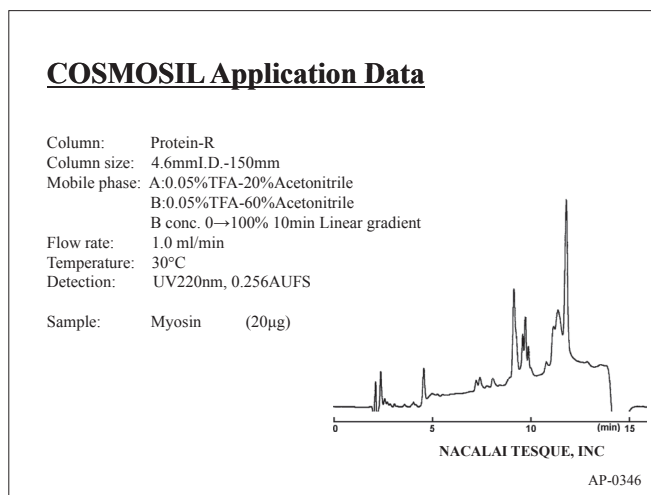

● Milk Protein

COSMOSIL Application Data

Column: Protein-R
Column size: 4.6mmI.D.-150mm
Mobile phase: A: 0.05%TFA-H₂O
B: 0.05%TFA-Acetonitrile
B conc. 20→80% 20min Linear gradient

Flow rate: 1.0 ml/min
Temperature: 30°C
Detection: UV220nm

Sample: Milk

Sample Preparation:
•Ultracentrifuged at 90,000 g for 1 hr.
•Clear supernatant solution was injected.

Injection vol.: 1.0µl

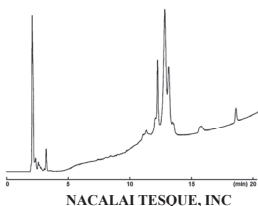

NACALAI TESQUE, INC

AP-1079

● Soy milk Protein

COSMOSIL Application Data

Column: Protein-R
Column size: 4.6mmI.D.-150mm
Mobile phase: A: 0.05%TFA-H₂O
B: 0.05%TFA-Acetonitrile
B conc. 20→80% 20min Linear gradient

Flow rate: 1.0 ml/min
Temperature: 30°C
Detection: UV220nm

Sample: Soybean milk

Sample Preparation:
•Ultracentrifuged at 90,000 g for 1 hr.
•Clear supernatant solution was injected.

Injection vol.: 1.0µl

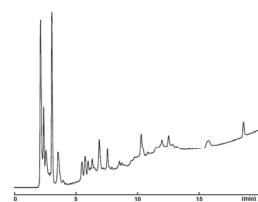

NACALAI TESQUE, INC

AP-1080

● Bacteria-derived Proteins

COSMOSIL Application Data

Column: Protein-R
Column size: 4.6mmI.D.-150mm
Mobile phase: A:0.05%TFA-20%Acetonitrile
B:0.05%TFA-60%Acetonitrile
B conc. 0→100% 10min Linear gradient

Flow rate: 1.0 ml/min
Temperature: 30°C
Detection: UV220nm, 0.256AUFS

Sample: 1; Choline Oxidase (6.0µg)
2; α-Amylase (3.0µg)
3; Glucose Oxidase (6.0µg)
4; Thermolysin (9.0µg)

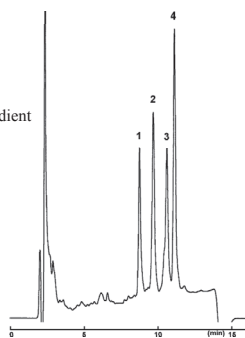

NACALAI TESQUE, INC

AP-0337

● Bacteria-derived Proteins

COSMOSIL Application Data

Column: Protein-R
Column size: 4.6mmI.D.-150mm
Mobile phase: A:0.05%TFA-20%Acetonitrile
B:0.05%TFA-60%Acetonitrile
B conc. 0→100% 10min Linear gradient

Flow rate: 1.0 ml/min
Temperature: 30°C
Detection: UV220nm, 0.256AUFS

Sample: 1; Actinase E (13.4µg)
2; Alcohol Dehydrogenase (6.6µg)

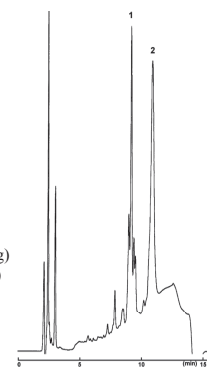

NACALAI TESQUE, INC

AP-0338

● Human-derived Proteins

COSMOSIL Application Data

Column: Protein-R
Column size: 4.6mmI.D.-150mm
Mobile phase: A:0.05%TFA-20%Acetonitrile
B:0.05%TFA-60%Acetonitrile
B conc. 0→100% 10min Linear gradient

Flow rate: 1.0 ml/min
Temperature: 30°C
Detection: UV220nm, 0.256AUFS

Sample: 1; Transferrin (1.5µg)
2; Albumin, Human (2.0µg)
3; Carbonic Anhydrase (1.0µg)

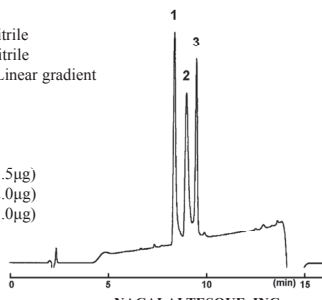

NACALAI TESQUE, INC

AP-0339

● Bovine-derived Proteins

COSMOSIL Application Data

Column: Protein-R
Column size: 4.6mmI.D.-150mm
Mobile phase: A:0.05%TFA-20%Acetonitrile
B:0.05%TFA-60%Acetonitrile
B conc. 0→100% 10min Linear gradient

Flow rate: 1.0 ml/min
Temperature: 30°C
Detection: UV220nm, 0.256AUFS

Sample: 1; Albumin, Bovine [BSA] (2.0µg)
2; L-Glutamic Dehydrogenase (1.5µg)
3; Carbonic Anhydrase (1.5µg)

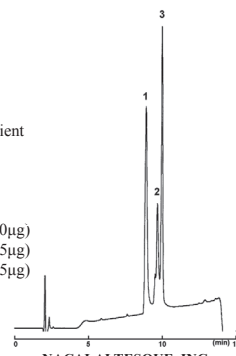

NACALAI TESQUE, INC

AP-0340

● Bovine-derived Proteins

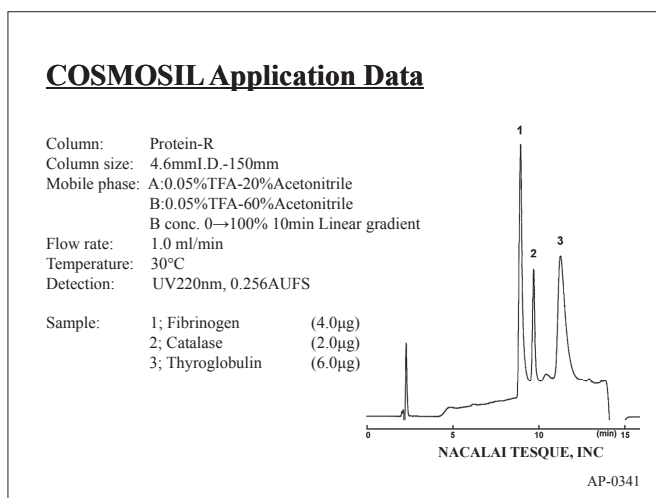

● Bovine Spleen-derived Proteins

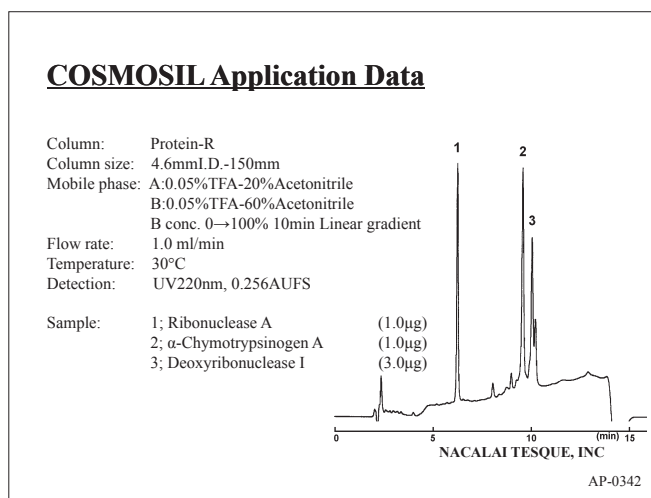

● Bovine Spleen-derived Proteins

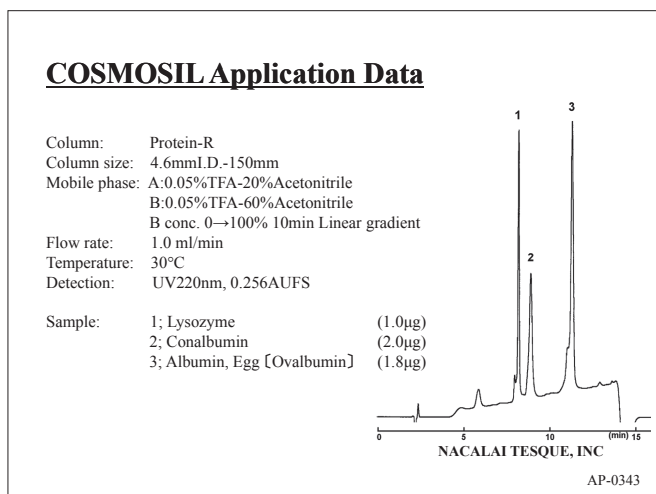

● Other Proteins

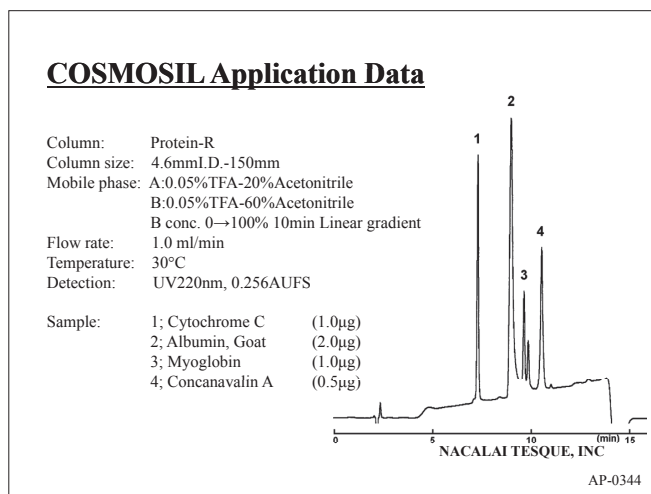

● Other Proteins

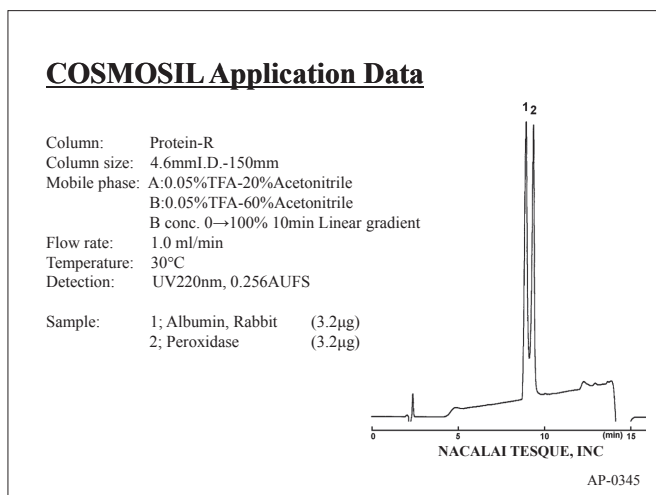

● Pyruvate Kinase

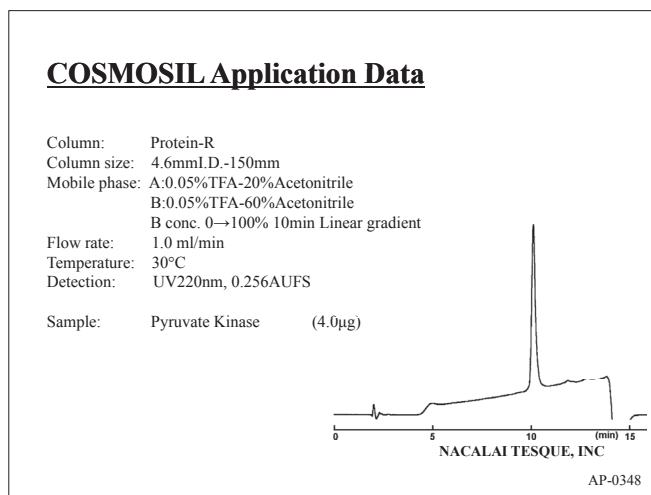

● Semi-purified Diaphorase

COSMOSIL Application Data

Column: Protein-R
Column size: 4.6mmI.D.-150mm
Mobile phase: A:0.05%TFA-20%Acetonitrile
B:0.05%TFA-60%Acetonitrile
B conc. 0→100% 10min Linear gradient
Flow rate: 1.0 ml/min
Temperature: 30°C
Detection: UV220nm, 0.256AUFS
Sample: Diaphorase (6.0µg)

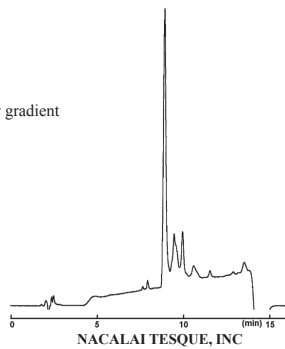

AP-0347

● Glycoproteins

COSMOSIL Application Data

Column: Protein-R
Column size: 4.6mmI.D.-150mm
Mobile phase: A: 0.05%TFA-20%Acetonitrile
B: 0.05%TFA-60%Acetonitrile
B conc. 0→100% 20min Linear gradient
Flow rate: 1.0 ml/min
Temperature: 30°C
Detection: UV220nm
Sample: Concanavalin A (1.0µg)

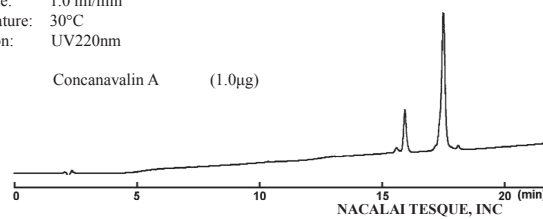

AP-0352

● Human Serum

COSMOSIL Application Data

Column: 5Diol-300-II
Column size: 7.5mmI.D.-600mm
Mobile phase: 20mmol/l Phosphate Buffer(pH 7.0)
+ 100mmol/l Na₂SO₄
Flow rate: 1.0 ml/min
Temperature: Room temperature
Detection: UV280nm
Sample: Human Serum

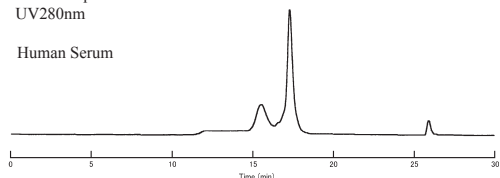

AP-0383

● Bovine Serum

COSMOSIL Application Data

Column: 5Diol-300-II
Column size: 7.5mmI.D.-600mm
Mobile phase: 20mmol/l Phosphate Buffer(pH 7.0)
+ 100mmol/l Na₂SO₄
Flow rate: 1.0 ml/min
Temperature: Room temperature
Detection: UV280nm
Sample: Bovine Serum

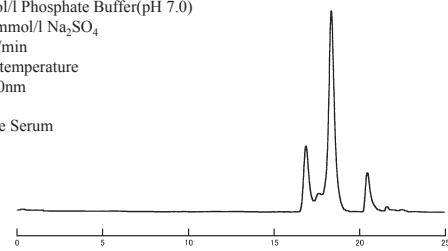

AP-0387

● Egg White

COSMOSIL Application Data

Column: 5Diol-300-II
Column size: 7.5mmI.D.-600mm
Mobile phase: 20mmol/l Phosphate Buffer(pH 7.0)
+ 100mmol/l Na₂SO₄
Flow rate: 1.0 ml/min
Temperature: Room temperature
Detection: UV280nm
Sample: Egg White

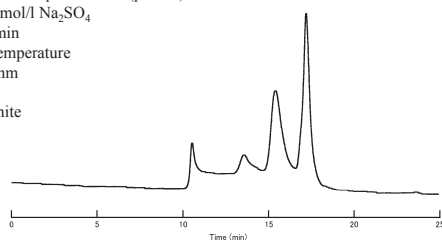

AP-0385

● Tau Protein

COSMOSIL Application Data

Column: Protein-R
Column size: 20mmI.D.-250mm
Mobile phase: A: 0.1%TFA-H₂O
B: 0.1%TFA-Acetonitrile
B conc. 20%(0-13min), 20→50%(13→43min)
Flow rate: 9.0 ml/min
Temperature: Room temperature
Detection: UV215nm
Sample: Recombinant human tau (2N4R)

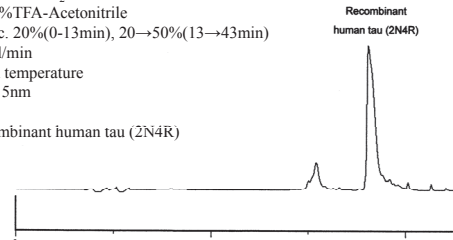

Data courtesy of Akihiko Takashima, Ph.D.
Laboratory for Alzheimer's Disease, RIKEN Brain Science Institute

AP-1150

● E. coli Proteins

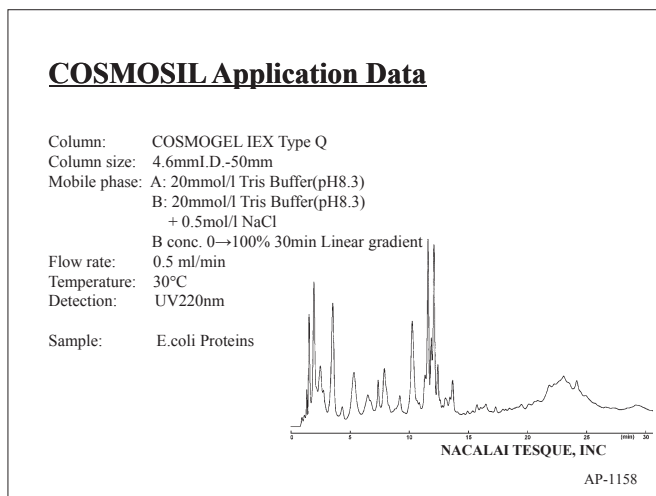

● HeLa Cell Proteins

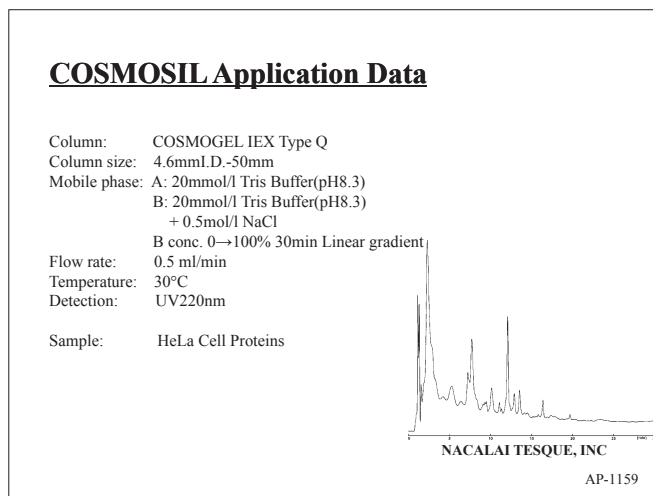

● Egg White

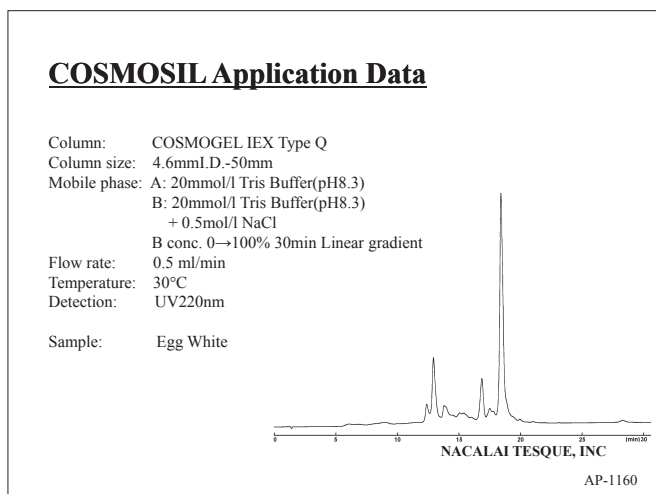

● IgG

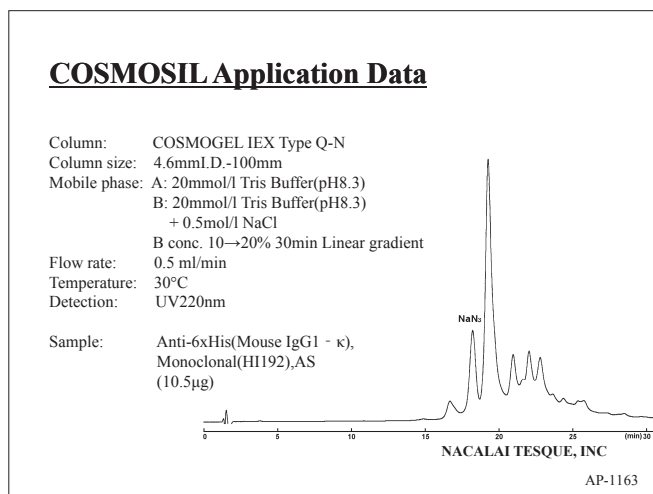

● Urease

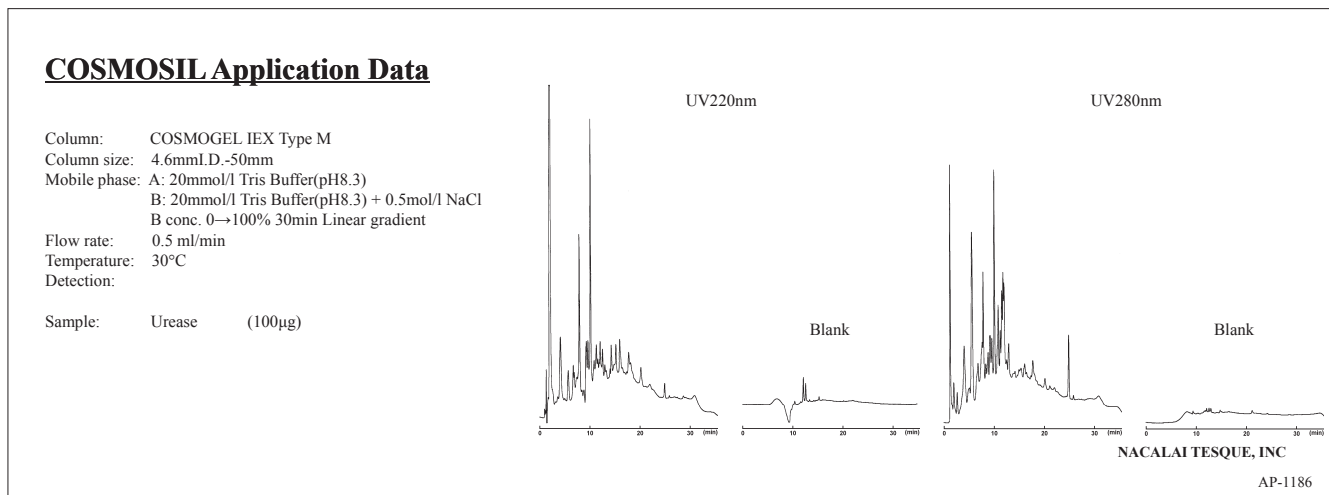

• Methoxyphenols

COSMOSIL Application Data

Column: 5C₁₈-MS-II
Column size: 4.6mm I.D.-150mm
Mobile phase: Methanol/ H₂O = 30/70
Flow rate: 1.0 ml/min
Temperature: 30°C
Detection: UV254nm

Sample: *o*-Methoxyphenol [Guaiacol] (3.3µg)
m-Methoxyphenol (3.3µg)
p-Methoxyphenol (3.3µg)

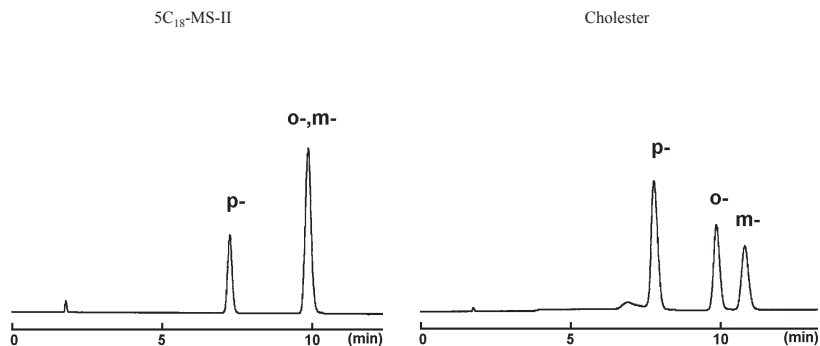

NACALAI TESQUE, INC

AP-1041

• Terphenyls

COSMOSIL Application Data

Column: 5C₁₈-MS-II
Column size: 4.6mm I.D.-150mm
Mobile phase: Methanol/ H₂O = 90/10
Flow rate: 1.0 ml/min
Temperature: 30°C
Detection: UV254nm

Sample: *o*-Terphenyl (0.15µg)
m-Terphenyl (0.05µg)
p-Terphenyl (0.075µg)

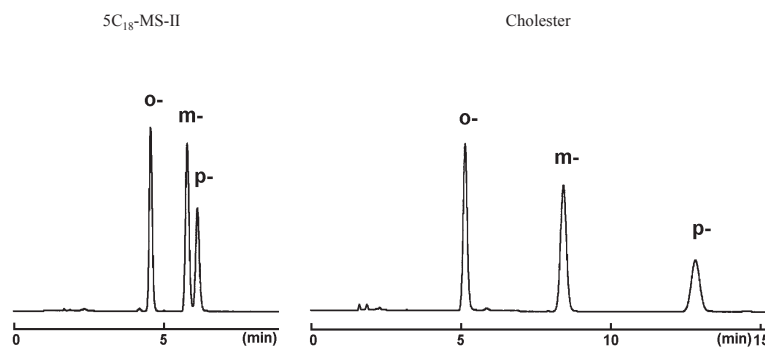

NACALAI TESQUE, INC

AP-1042

• Chlorophenols

COSMOSIL Application Data

Column: 5C₁₈-MS-II
Column size: 4.6mm I.D.-150mm
Mobile phase: Methanol/ H₂O = 50/50
Flow rate: 1.0 ml/min
Temperature: 30°C
Detection: UV254nm

Sample: *o*-Chlorophenol (2.0µg)
m-Chlorophenol (2.0µg)
p-Chlorophenol (4.0µg)

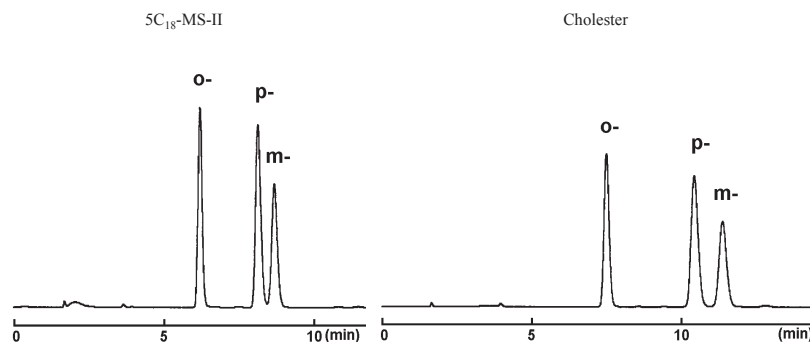

NACALAI TESQUE, INC

AP-1043

● Stilbenes

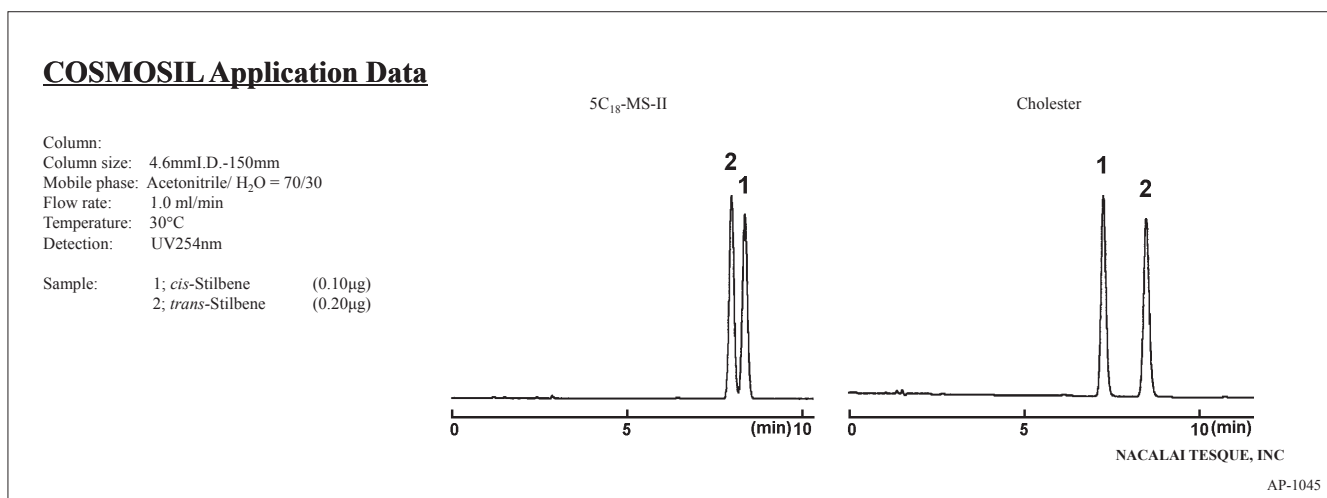

● Halogenated Benzenes

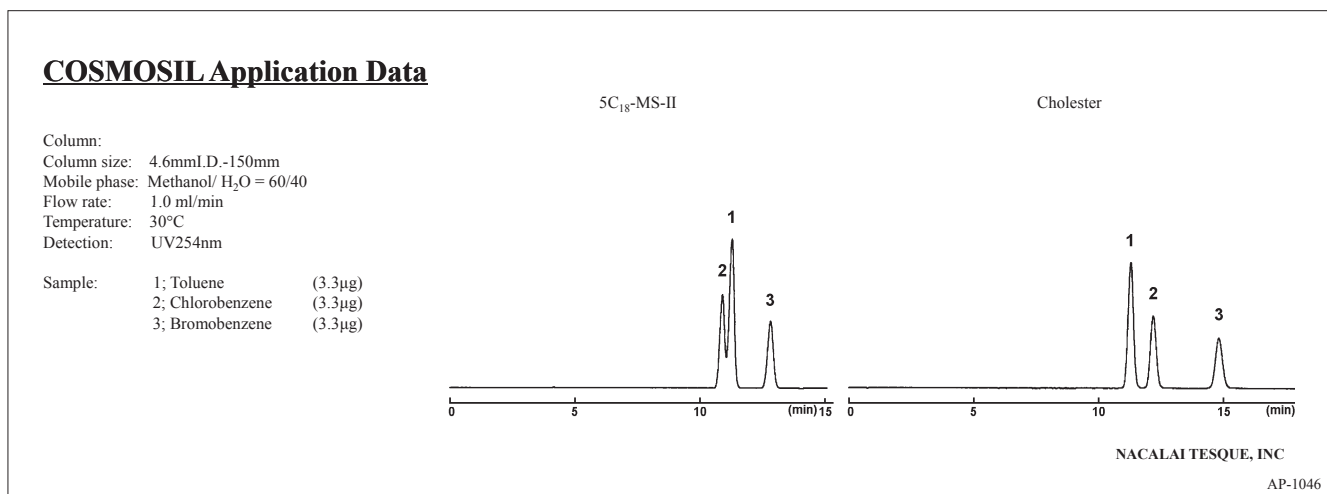

● Fluorinated Benzenes

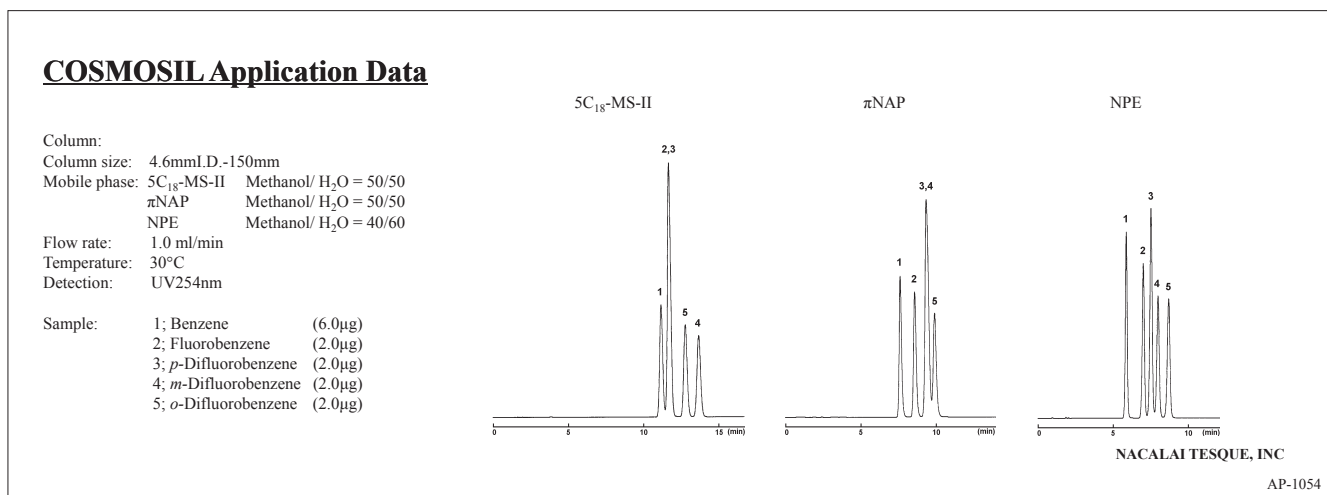

● Plasticizer (Branched-chain Isomeric Mixture)

COSMOSIL Application Data

Column: 5CN-MS
 Column size: 4.6mmI.D.-150mm
 Mobile phase: (Acetonitrile/ H₂O = 55/45)
 Flow rate: 1.0 ml/min
 Temperature: 40°C
 Detection: UV220nm

Sample: 1; Diisononyl Phthalate [DINP] (2.0 μg)
 2; Diisodecyl Phthalate [DIDP] (2.0 μg)

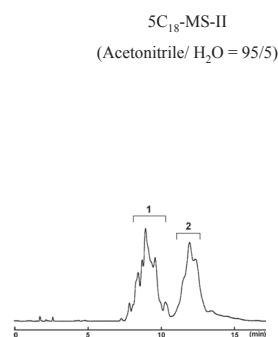
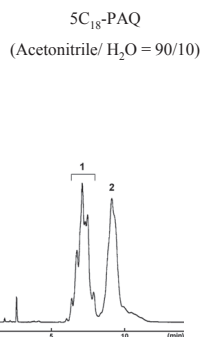
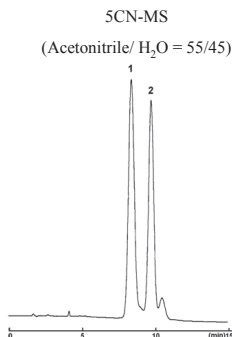

NACALAI TESQUE, INC

AP-1193

● Plasticizer

COSMOSIL Application Data

Column: 2.5C₁₈-MS-II
 Column size: 2.0mmI.D.-100mm
 Mobile phase: Methanol/ H₂O = 90/10
 Flow rate: 0.35 ml/min
 Temperature: 40°C
 Detection: UV220nm

Sample:
 1; Di-*n*-butyl Phthalate [DBP] (0.05mg/ml)
 2; *n*-Butyl Benzyl Phthalate [BBP] (0.05mg/ml)
 3; Dioctyl Phthalate [DOP][DEHP] (0.05mg/ml)
 4; Di-*n*-octyl Phthalate [DNOP] (0.05mg/ml)
 5; Diisononyl Phthalate [DINP] (0.25mg/ml)
 6; Diisodecyl Phthalate [DIDP] (0.25mg/ml)
 Injection Vol. 5.0μl

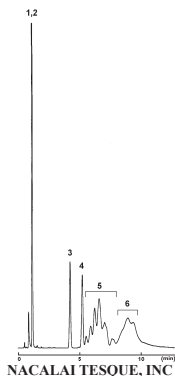

NACALAI TESQUE, INC

AP-1198

● Uracil and Uridine

COSMOSIL Application Data

Column: HILIC
 Column size: 4.6mmI.D.-250mm
 Mobile phase: Acetonitrile / H₂O = 90/10
 Flow rate: 1.0 ml/min
 Temperature: 30°C
 Detection: UV254nm

Sample: 1; Uracil (0.1μg)
 2; Uridine (0.2μg)

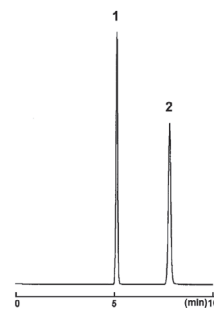

NACALAI TESQUE, INC

AP-0299

● Glycerol

COSMOSIL Application Data

Column: HILIC
 Column size: 4.6mmI.D.-250mm
 Mobile phase: Acetonitrile / H₂O = 95/5
 Flow rate: 1.0 ml/min
 Temperature: 30°C
 Detection: RI

Sample: 1; Trimethylene Glycol (20μg)
 2; Glycerol (20μg)

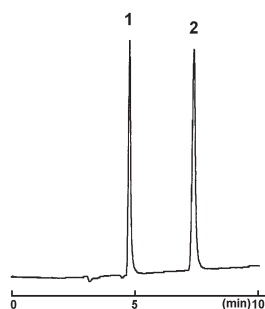

NACALAI TESQUE, INC

AP-0301

● Ethylene Glycol

COSMOSIL Application Data

Column: HILIC
 Column size: 4.6mmI.D.-250mm
 Mobile phase: Acetonitrile / H₂O = 95/5
 Flow rate: 1.0 ml/min
 Temperature: 30°C
 Detection: RI

Sample: 1; Trimethylene Glycol (20μg)
 2; Ethylene Glycol (20μg)

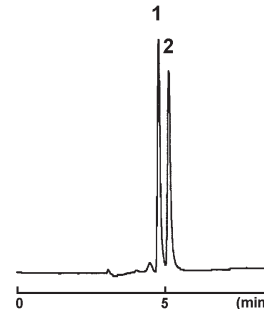

NACALAI TESQUE, INC

AP-0303

● Diethylene Glycol

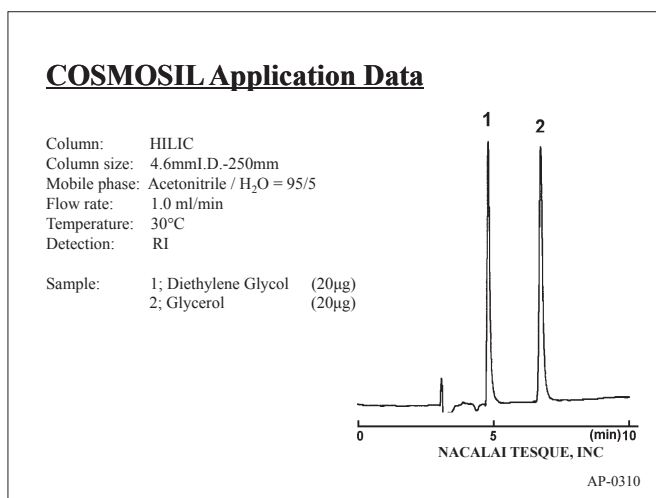

● Oxalic Acid

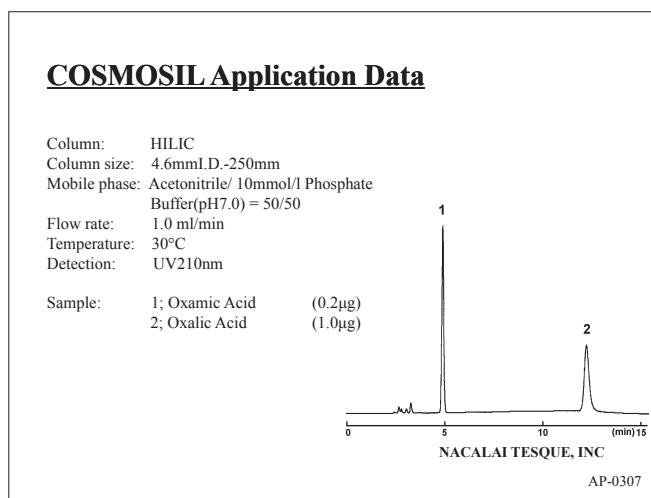

● Hydrophilic Compounds (Ionicity)

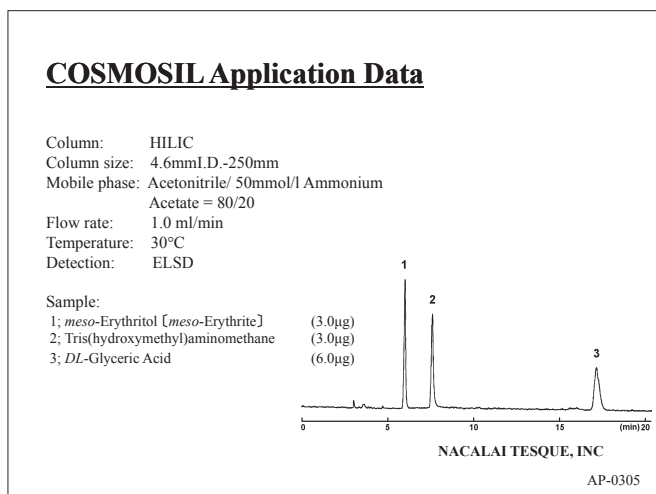

● Fluorine Compounds

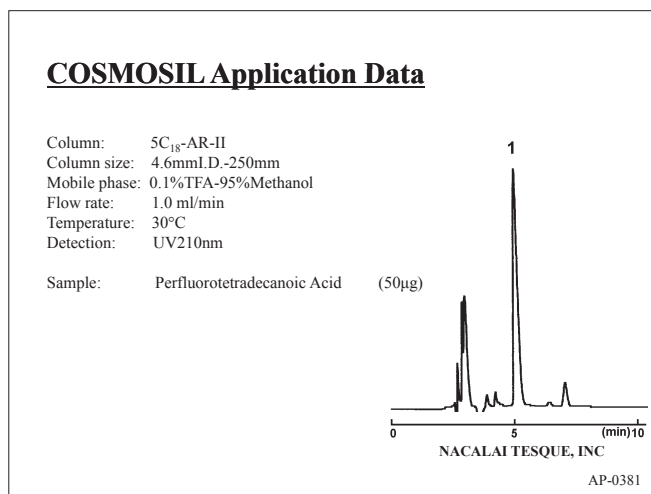

● Urea

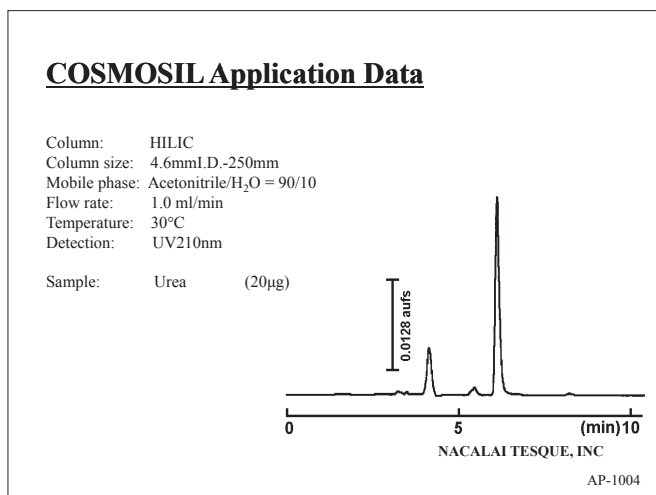

● Acid Compounds

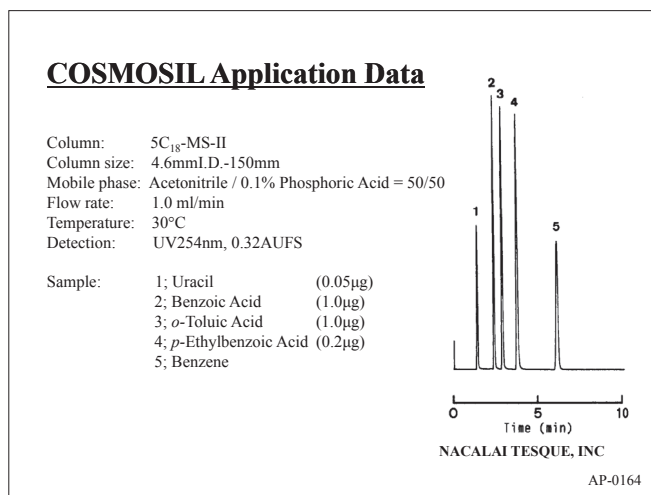

● Basic Compounds

COSMOSIL Application Data

Column: 5C₁₈-AR-II
 Column size: 4.6mmI.D.-150mm
 Mobile phase: Methanol/ 20mmol/l Phosphate
 Buffer(pH3) = 50/50
 Flow rate: 1.0 ml/min
 Temperature: 30°C
 Detection: UV254nm, 0.2AUFS

Sample: 1; *o*-Ethylpyridine (0.4μg)
 2; *N,N*-Dimethylaniline (0.6μg)

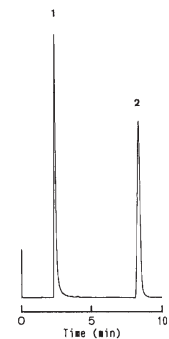

NACALAI TESQUE, INC

AP-0166

● Monosubstituted Benzenes (20 samples)

COSMOSIL Application Data

Column: 5C₁₈-MS-II
 Column size: 4.6mmI.D.-150mm
 Mobile phase: Methanol / H₂O
 = 60/40
 Flow rate: 1.0 ml/min
 Temperature: 30°C
 Detection: UV254nm, 0.16AUFS

Sample:
 1: Benzamide (0.49μg)
 2: Aniline (0.4μg)
 3: Phenol (0.67μg)
 4: Benzonitrile (0.83μg)
 5: Acetophenone (0.04μg)
 6: Styrene Oxide (1.1μg)
 7: Nitrobenzene (0.06μg)
 8: Methylbenzoate (0.62μg)
 9: Anisole (0.79μg)
 10: Fluorobenzene (0.65μg)
 11: Benzene (0.79μg)
 12: *N,N*-Dimethylaniline (0.15μg)
 13: Thioanisole (0.12μg)
 14: Chlorobenzene (7.05μg)
 15: Toluene (5.84μg)
 16: Bromobenzene (15.37μg)
 17: Iodobenzene (3.66μg)
 18: Ethylbenzene (14.1μg)
 19: *n*-Propylbenzene (15.93μg)
 20: *n*-Butylbenzene (15.93μg)

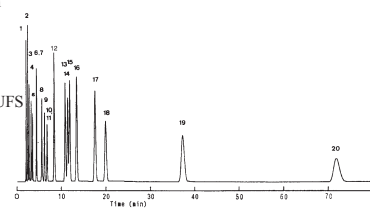

NACALAI TESQUE, INC

AP-0154

● Furans

COSMOSIL Application Data

Column: 5C₁₈-MS-II
 Column size: 4.6mmI.D.-150mm
 Mobile phase: Acetonitrile/ H₂O = 30/70
 Flow rate: 1.0 ml/min
 Temperature: 30°C
 Detection: UV220nm, 0.2AUFS

Sample: 1; Furfuryl alcohol (0.13μg)
 2; Furfural (0.25μg)
 3; Furan (0.23μg)

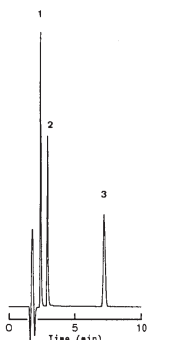

NACALAI TESQUE, INC

AP-0155

● Phenolphthalein

COSMOSIL Application Data

Column: 5C₁₈-MS-II
 Column size: 4.6mmI.D.-150mm
 Mobile phase: Methanol / H₂O = 50/50
 Flow rate: 1.0 ml/min
 Temperature: 30°C
 Detection: UV254nm, 0.1AUFS

Sample: Phenolphthalein (0.6μg)

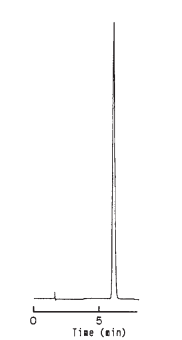

NACALAI TESQUE, INC

AP-0156

● Anilines

COSMOSIL Application Data

Column: 5C₁₈-MS-II
 Column size: 4.6mmI.D.-150mm
 Mobile phase: Acetonitrile / 0.1% Phosphoric Acid = 50/50
 Flow rate: 1.0 ml/min
 Temperature: 30°C
 Detection: UV254nm

Sample: 1; Aniline
 2; *p*-Nitroaniline
 3; 2,4-Dinitroaniline

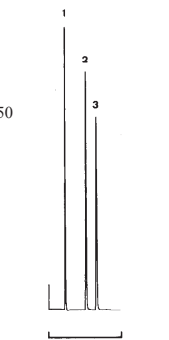

NACALAI TESQUE, INC

AP-0160

● Esters and others

COSMOSIL Application Data

Column: 5C₁₈-MS-II
 Column size: 4.6mmI.D.-150mm
 Mobile phase: Acetonitrile/ H₂O = 50/50
 Flow rate: 1.0 ml/min
 Temperature: 30°C
 Detection: UV254nm, 0.32AUFS

Sample: 1; Uracil
 2; Pyridine
 3; Phenol
 4; Ethyl *p*-Hydroxybenzoate
 5; *n*-Propyl *p*-Hydroxybenzoate
 6; Methyl Salicylate
 7; Toluene
 8; Ethyl Salicylate

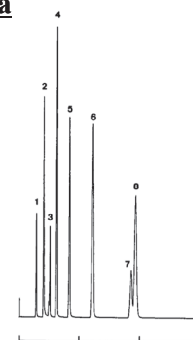

NACALAI TESQUE, INC

AP-0163

• Aminophenols

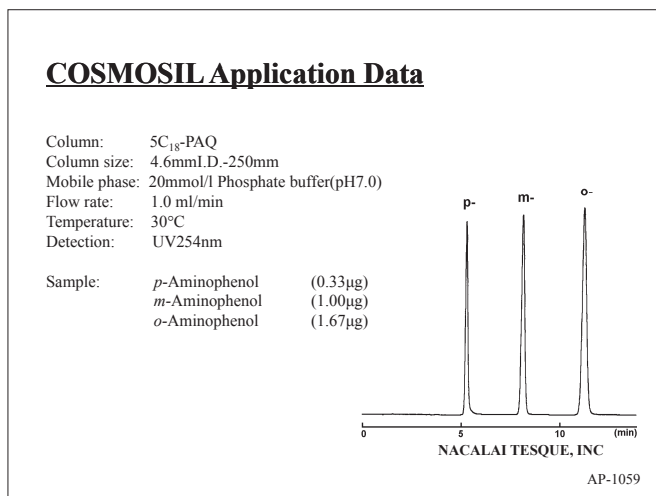

• Polyaromatic Compounds

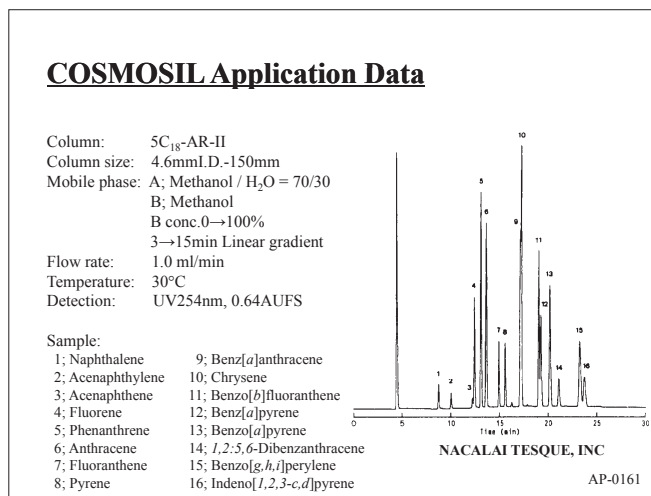

• Benzylpyridines

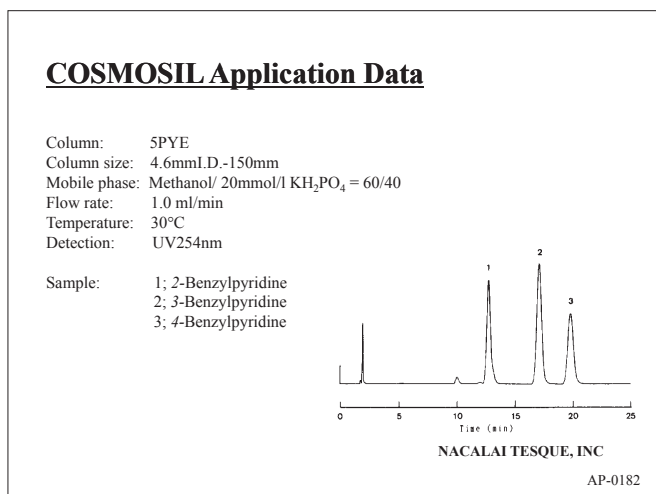

• Carvylacetate

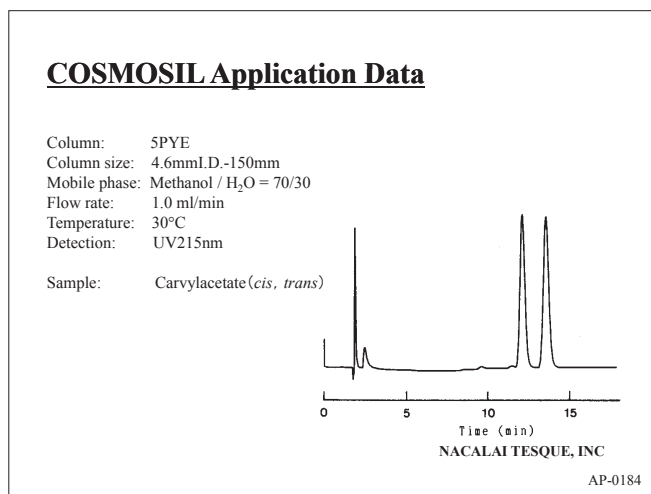

• Diastereomers

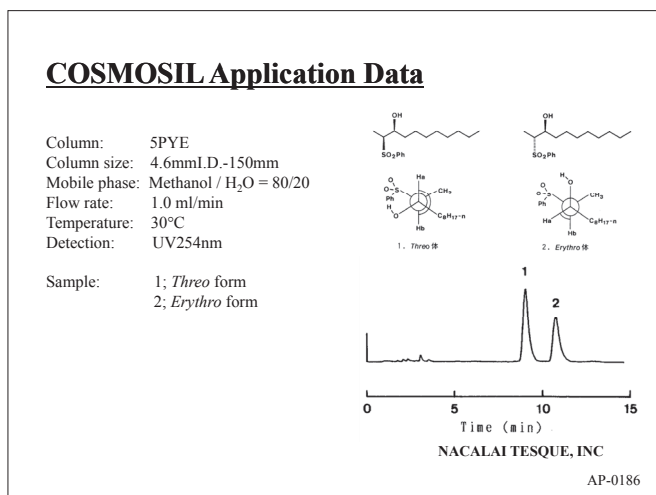

• Surfactant

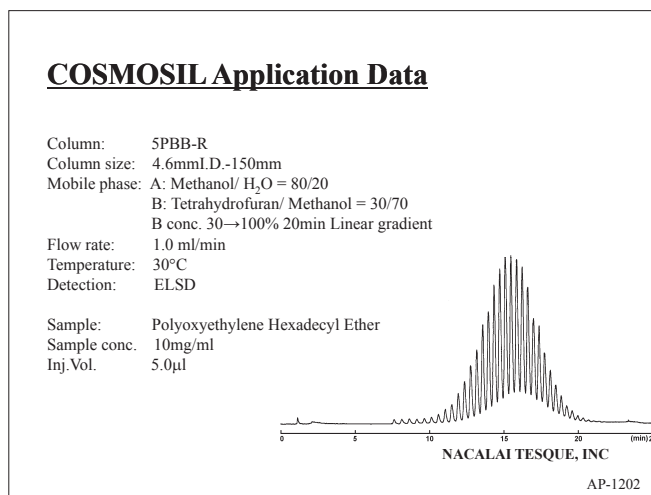

- Surfactant

COSMOSIL Application Data

Column: 5PBB-R
 Column size: 4.6mm I.D.-150mm
 Mobile phase: A: Methanol/H₂O = 80/20
 B: Tetrahydrofuran/ Methanol = 30/70
 B conc. 30→100% 20min Linear gradient
 Flow rate: 1.0 ml/min
 Temperature: 30°C
 Detection: ELSD
 Sample: Polyoxyethylene Lauryl Ether (10mg/ml)
 Inj. Vol. 5.0μl

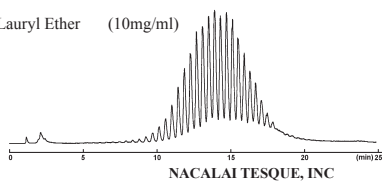

- Aromatic Compounds

COSMOSIL Application Data

Column: 5PBB-R
 Column size: 4.6mm I.D.-150mm
 Mobile phase: Acetonitrile/H₂O = 70/30
 Flow rate: 1.0 ml/min
 Temperature: 30°C
 Detection: UV254nm

Sample: 1; Diphenylmethane (5.80μg)
 2; Fluorene (0.13μg)

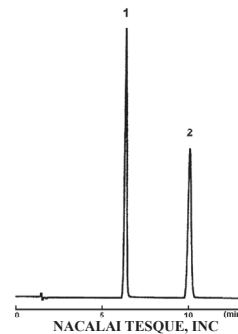

- Aromatic Compounds

COSMOSIL Application Data

Column: 5PBB-R
 Column size: 4.6mm I.D.-150mm
 Mobile phase: Acetonitrile/H₂O = 60/40
 Flow rate: 1.0 ml/min
 Temperature: 30°C
 Detection: UV254nm

Sample: 1; Dibenzosuberone (0.25μg)
 2; Dibenzosuberone (0.10μg)

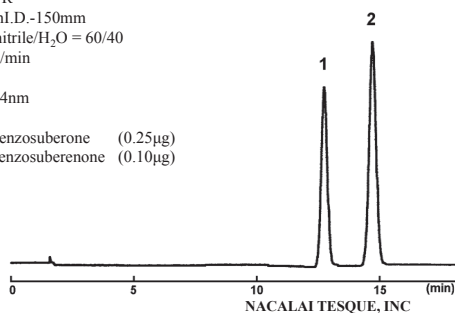

- Aromatic Compounds

COSMOSIL Application Data

Column: 5PBB-R
 Column size: 4.6mm I.D.-150mm
 Mobile phase: Methanol/H₂O = 70/30
 Flow rate: 1.0 ml/min
 Temperature: 30°C
 Detection: UV254nm

Sample: 1; *n*-Propylbenzene (27.9μg)
 2; Allylbenzene (0.45μg)

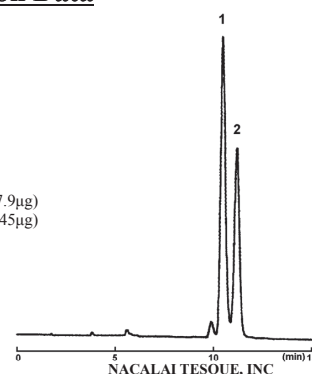

- Aromatic Compounds

COSMOSIL Application Data

Column: 5PBB-R
 Column size: 4.6mm I.D.-150mm
 Mobile phase: Methanol/H₂O = 90/10
 Flow rate: 1.0 ml/min
 Temperature: 30°C
 Detection: UV254nm

Sample: 1; 1,1'-Binaphthyl (0.60μg)
 2; Perylene (0.72μg)

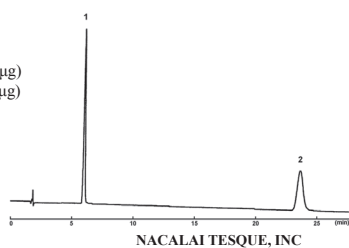

- Coloring Agent (CBB)

COSMOSIL Application Data

Column: 5C₁₈-MS-II
 Column size: 4.6mm I.D.-150mm
 Mobile phase: Methanol/ 20mmol/l Phosphate
 buffer(pH2.5) = 70/30

Flow rate: 1.0 ml/min
 Temperature: 30°C
 Detection: UV254nm

Sample: Coomassie Brilliant Blue G-250 (3.0μg)

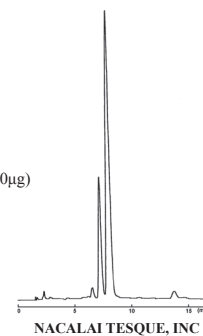

4. Reference List

COSMOSIL HPLC columns have been referenced in more than 5000 scientific literatures. The followings are recent references of COSMOSIL special columns. Copies are not available directly from us due to the copyright.

No.	Column	TITLE	AUTHOR	JOURNAL	YEAR	VOL. (ISSUE)	PAGE
1	Cholesterol π NAP	Four new glucosides from the aerial parts of <i>Mediasia macrophylla</i>	Shin-ichiro Kurimoto, Mamoru Okasaka, Yoshiki Kashiwada, Olimjon K. Kodzhimatov and Yoshihisa Takaishi	Journal of Natural Medicines	2011	65 (1)	180-185
2	Cholesterol	Inhibitory Effect of Cyclic Trihydroxamate Siderophore, Desferrioxamine E, on the Biofilm Formation of <i>Mycobacterium</i> Species	Shunsuke Ishida, Masayoshi Arai, Hiroki Niikawa and Motomasa Kobayashi	Biological & Pharmaceutical Bulletin	2011	34 (6)	917-920
3	Cholesterol	A study on thermal stability of lycopene in tomato in water and oil food systems using response surface methodology	Honest H. Kessy, Huanwei Zhang, Lianfu Zhang	International Journal of Food Science & Technology	2011	46 (1)	209-215
4	Cholesterol	Melicodenines A and B, novel Diels-Alder type adducts isolated from <i>Melicope denhamii</i>	Ken-ichi Nakashima, Masayoshi Oyama, Tetsuro Ito, Joko Ridho Witono, Dedy Darnaedi, Toshiyuki Tanaka, Jin Murata, Munekazu Iinuma	Tetrahedron Letters	2011	52 (36)	4694-4696
5	Cholesterol	Effects of a <i>Citrus depressa</i> Hayata (shikuwasa) extract on obesity in high-fat diet-induced obese mice	Young-Sil Lee, Byung-Yoon Cha, Kiyoto Saito, Sun-Sil Choi, Xiao Xing Wang, Bong-Keun Choi, Takayuki Yonezawa, Toshiaki Teruya, Kazuo Nagai, Je-Tae Woo	Phytomedicine	2011	18 (8-9)	648-654
6	5C ₁₈ -MS-II Cholesterol π NAP	Triterpenes and a triterpene glucoside from <i>Dysoxylum cumingianum</i>	Shin-ichiro Kurimoto, Yoshiki Kashiwada, Kuo-Hsiung Lee, Yoshihisa Takaishi	Phytochemistry	2011	In Press	
7	Cholesterol	Direct Dehydrative Pyridylthio-Glycosidation of Unprotected Sugars in Aqueous Media Using 2-Chloro-1,3-dimethylimidazolium Chloride as a Condensing Agent	Naoki Yoshida, Dr. Masato Noguchi, Dr. Tomonari Tanaka, Takeshi Matsumoto, Naoya Aida, Dr. Masaki Ishihara, Dr. Atsushi Kobayashi, Prof. Dr. Shin-ichiro Shoda	Chemistry – An Asian Journal	2011	6 (7)	1876-1885
8	Cholesterol	Seven new dammarane triterpenes from the floral spikes of <i>Betula platyphylla</i> var. <i>japonica</i>	Juan Xiong, Masatoshi Taniguchi, Yoshiki Kashiwada, Takashi Yamagishi and Yoshihisa Takaishi	Journal of Natural Medicines	2011	65 (1)	217-223
9	Cholesterol	Osteoclast-forming suppressing compounds, gargarols A, B, and C, from the edible mushroom <i>Grifola gargar</i>	Jing Wu, Jae-Hoon Choi, Miyuki Yoshida, Hirofumi Hirai, Etsuko Harada, Kikuko Masuda, Tomoyuki Koyama, Kazunaga Yazawa, Keiichi Noguchi, Kazuo Nagasawa	Tetrahedron	2011	67 (35)	6576-6581
10	Cholesterol	Contribution of cinnamic acid analogues in rosmarinic acid to inhibition of snake venom induced hemorrhage	Hnin Thanda Aung, Tadashi Furukawa, Toshiaki Nikai, Masatake Niwa, Yoshiaki Takaya	Bioorganic & Medicinal Chemistry	2011	19 (7)	2392-2396
11	Cholesterol	Applanatines A-E from the culture broth of <i>Ganoderma applanatum</i>	Keiji Fushimi, Madoka Horikawa, Kaori Suzuki, Atsushi Sekiya, Susumu Kanno, Susumu Shimura, Hirokazu Kawagishi	Tetrahedron	2010	66 (48)	9332-9335
12	Cholesterol 140C ₁₈ PREP	Four New Cembrane Diterpenes Isolated from an okinawan Soft Coral <i>Lobophytum crassum</i> with Inhibitory Effects on Nitric Oxide Production	Mpanzu Wanzola, Takaaki Furuta, Yasuhisa Kohno, Shunichi Fukumitsu, Shuhei Yasukochi, Kosuke Watari, Chiaki Tanaka, Ryuichi Higuchi and Tomofumi Miyamoto	CHEMICAL & PHARMACEUTICAL BULLETIN	2010	58 (9)	1203-1209
13	Cholesterol	Nobiletin improves hyperglycemia and insulin resistance in obese diabetic ob/ob mice	Young-Sil Lee, Byung-Yoon Cha, Kiyoto Saito, Hiroshi Yamakawa, Sun-Sil Choi, Kohji Yamaguchi, Takayuki Yonezawa, Toshiaki Teruya, Kazuo Nagai, Je-Tae Woo	Biochemical Pharmacology	2010	79 (11)	1674-1683
14	Cholesterol	Study of solvation processes on cholesterol bonded phases	Boguslaw Buszewski, Szymon Bocian, Maria Matyska, Joseph Pesek	Journal of Chromatography A	2010	1218 (3)	441-448
15	Cholesterol	Study of the retention and selectivity of cholesterol bonded phases with different linkage spacers	Szymon Bocian, Maria Matyska, Joseph Pesek, Boguslaw Buszewski	Journal of Chromatography A	2010	1217 (44)	6891-6897
16	Cholesterol 5C ₁₈ -AR-II	Isolation and structure of koshikalide, a 14-membered macrolide from the marine cyanobacterium <i>Lyngbya</i> sp.	Arihiro Iwasaki, Toshiaki Teruya and Kiyotake Suenaga	Tetrahedron Letters	2010	51 (6)	959-960
17	Cholesterol π NAP	A C ₁₄ -polyacetylenic glucoside with an α -pyrone moiety and four C ₁₀ -polyacetylenic glucosides from <i>Mediasia macrophylla</i>	Shin-ichiro Kurimoto, Mamoru Okasaka, Yoshiki Kashiwada, Olimjon K. Kodzhimatov and Yoshihisa Takaishi	Phytochemistry	2010	71 (5-6)	688-692
18	π NAP	Development and validation of a stability-indicating LC method for determining Palonosetron hydrochloride, its related compounds and degradation products using naphthaethyl stationary phase	M. Vishnu Murthy, Katkam Srinivas, Ramesh Kumar, K. Mukkanti	Journal of Pharmaceutical and Biomedical Analysis	2011	56 (2)	429-435
19	π NAP	Maklamicin, an Antibacterial Polyketide from an Endophytic <i>Micromonospora</i> sp.	Yasuhiro Igarashi, Hiromi Ogura, Kazuo Furihata, Naoya Oku, Chantra Indananda, and Arinthip Thamchaipenent	J. Nat. Prod.	2011	74 (4)	670-674
20	π NAP	Gneyulins A and B, Stilbene Trimers, and Noidesols A and B, Dihydroflavonol-C-Glucosides, from the Bark of <i>Gnetum gnetum</i>	Yoko Shimokawa, Yusuke Akao, Yusuke Hirasawa, Khalijah Awang, A. Hamid A. Hadi, Seizo Sato, Chihiro Aoyama, Jiro Takeo, Motoo Shiro and Hiroshi Morita	J. Nat. Prod.	2010	73 (4)	763-767
21	HILIC	Stationary and mobile phases in hydrophilic interaction chromatography: a review	Pavel Jandera	Analytica Chimica Acta	2011	692 (1-2)	1-25
22	HILIC Sugar-D	Chromatographic characterization of hydrophilic interaction liquid chromatography stationary phases: Hydrophilicity, charge effects, structural selectivity, and separation efficiency	Yuusuke Kawachi, Tohru Ikegami, Hirotaka Takubo, Yuka Ikegami, Masatoshi Miyamoto, Nobuo Tanaka	Journal of Chromatography A	2011	1218 (35)	5903-5919

I. HPLC Columns

II. UHPLC Columns

III. Preparative Packing Materials

IV. Related Products

V. Applications

VI. Technical Notes

VII. Index

No.	Column	TITLE	AUTHOR	JOURNAL	YEAR	VOL. (ISSUE)	PAGE
23	HILIC	Retention and selectivity of stationary phases for hydrophilic interaction chromatography	Yong Guo, Sheetal Gaiki	Journal of Chromatography A	2011	1218 (35)	5920-5938
24	HILIC	The different decomposition properties of diazolidinyl urea in cosmetics and patch test materials	Takahiro Doi, Keiji Kajimura, Shuzo Taguchi	Contact Dermatitis	2011	65 (2)	81-91
25	HILIC	A Novel Glucosylation Reaction on Anthocyanins Catalyzed by Acyl-Glucose-Dependent Glucosyltransferase in the Petals of Carnation and Delphinium	Yuki Matsuba, Nobuhiro Sasaki, Masayuki Tera, Masachika Okamura, Yutaka Abe, Emi Okamoto, Haruka Nakamura, Hisakage Funabashi, Makoto Takatsu, Mikako Saito, Hideaki Matsuoka, Kazuo Nagasawa and Yoshihiro Ozeki	The Plant Cell	2010	22 (10)	3374-3389
26	HILIC	Molecular identification of unsaturated uronate reductase prerequisite for alginate metabolism in <i>Sphingomonas</i> sp. A1	Ryuichi Takase, Akihito Ochiai, Bunzo Mikami, Wataru Hashimoto, Kousaku Murata	Biochimica et Biophysica Acta (BBA) - Proteins & Proteomics	2010	1804 (9)	1925-1936
27	HILIC	Hepatoprotective Effects of Flavonoids from Shekwasha (<i>Citrus depressa</i>) against D-Galactosamine-Induced Liver Injury in Rats	Toshiyuki AKACHI, Yasuyuki SHIINA, Yayoi OHISHI, Takumi KAWAGUCHI, Hirokazu KAWAGISHI, Tatsuya MORITA, Makoto MORI and Kimio SUGIYAMA	Journal of Nutritional Science and Vitaminology	2010	56 (1)	60-67
28	HILIC	Determination of isoascorbic acid in fish tissue by hydrophilic interaction liquid chromatography-ultraviolet detection	Spyros Drivelos, Marilena E. Dasenaki and Nikolaos S. Thomaidis	Analytical and Bioanalytical Chemistry	2010	397 (6)	2199-2210
29	HILIC	Approach to hydrophilic interaction chromatography column selection: Application to neurotransmitters analysis	Raluca-Ioana Chirita, Caroline West, Adriana-Luminita Finaru, Claire Elfakir	Journal of Chromatography A	2010	1217 (18)	3091-3104
30	HILIC 5C ₁₈ -MS-II	Inhibitory Effects of Acylated Acyclic Sesquiterpene Oligoglycosides from the Pericarps of <i>Sapindus rarak</i> on Tumor Necrosis Factor- α -Induced Cytotoxicity	Toshio Morikawa, Yuanyuan Xie, Kiyofumi Ninomiya, Masaki Okamoto, Osamu Muraoka, Dan Yuan, Masayuki Yoshikawa and Takao Hayakawa	CHEMICAL & PHARMACEUTICAL BULLETIN	2010	58 (9)	1276-1280
31	HILIC	Unusual amino acid derivatives from the mushroom <i>Pleurocybella porrigens</i>	Takumi Kawaguchi, Tomohiro Suzuki, Yuka Kobayashi, Shinya Kodani, Hirofumi Hirai, Kaoru Nagai and Hirokazu Kawagishi	Tetrahedron	2010	66 (2)	504-507
32	Sugar-D	DedA Protein Relates to Action-Mechanism of Halicyclamine A, a Marine Spongan Macrocyclic Alkaloid, as an Anti-dormant Mycobacterial Substance	Masayoshi Arai, Liu Liu, Takao Fujimoto, Andi Setiawan and Motomasa Kobayashi	Marine Drugs	2011	9 (6)	984-993
33	Sugar-D	Efficient ¹ H-NMR Quantitation and Investigation of N-Acetyl-D-glucosamine (GlcNAc) and N,N'-Diacetylchitobiose (GlcNAc) ₂ from Chitin	Fu-Chien Liu, Chung-Ren Su, Tzi-Yi Wu, Shyh-Gang Su, Huey-Lang Yang, John Han-You Lin and Tian-Shung Wu	Int. J. Mol. Sci.	2011	12	5828-5843
34	Sugar-D	New radiosynthesis of 2-deoxy-2-[¹⁸ F]fluoroacetamido-d-glucopyranose and its evaluation as a bacterial infections imaging agent	Miguel E. Martínez, Yasushi Kiyono, Sakon Noriki, Kunihiro Inai, Kathryn S. Mandap, Masato Kobayashi, Tetsuya Mori, Yuji Tokunaga, Vijay N. Tiwari, Hidehiko Okazawa, Yasuhisa Fujibayashi, Tatsuo Ido	Nuclear Medicine and Biology	2011	38 (6)	807-817
35	Sugar-D	Molecular Cloning and Characterization of a β -l-Arabinobiosidase in <i>Bifidobacterium longum</i> That Belongs to a Novel Glycoside Hydrolase Family	Kiyotaka Fujita, Shiho Sakamoto, Yuki Ono, Masahiro Wakao, Yasuo Suda, Kanefumi Kitahara and Toshihiko Suganuma	The Journal of Biological Chemistry	2011	286	5143-5150
36	Sugar-D	New Phenylpropanoid Glycosides from <i>Juniperus communis</i> var. <i>depressa</i>	Naoki IIDA, Yuka INATOMI, Hiroko MURATA, Jin MURATA, Frank A. LANG, Toshiyuki TANAKA, Tsutomu NAKANISHI and Akira INADA	CHEMICAL & PHARMACEUTICAL BULLETIN	2010	58 (5)	742-746
37	Sugar-D	Novel phenolic glycosides, adenophorases A-E, from <i>Adenophora</i> roots	Yuka Koike, Motonori Fukumura, Yasuaki Hirai, Yumiko Hori, Shiho Usui, Toshiyuki Atsumi and Kazuo Torizuka	Journal of Natural Medicines	2010	64(3)	245-251
38	Sugar-D	Quantitative determination of potent α -glucosidase inhibitors, salacinol and kotalanol, in <i>Salacia</i> species using liquid chromatography-mass spectrometry	Osamu Muraoka, Toshio Morikawa, Sohachiro Miyake, Junji Akaki, Kiyofumi Ninomiya and Masayuki Yoshikawa	Journal of Pharmaceutical and Biomedical Analysis	2010	52 (5)	770-773
39	Sugar-D	Structural characterization of N-linked oligosaccharides of Defibrase from <i>Agkistrodon acutus</i> by sequential exoglycosidase digestion and MALDI-TOF mass spectrometry	Xiaoqing Luo, Huaxin Yang, Chenggang Liang and Shaohong Jin	Toxicon	2010	55 (2-3)	421-429
40	CNT	Thin-Film Transistors with Length-Sorted DNA-Wrapped Single-Wall Carbon Nanotubes	Yuki Asada, Yasumitsu Miyata, Kazunari Shiozawa, Yutaka Ohno, Ryo Kitaura, Takashi Mizutani, and Hisanori Shinohara	J. Phys. Chem. C	2011	115 (1)	270-273
41	CNT-300 CNT-1000 CNT-2000	Chromatographic Separation of Highly Soluble Diamond Nanoparticles Prepared by Polyglycerol Grafting	Li Zhao, Tatsuya Takimoto, Masaaki Ito, Naoko Kitagawa, Takahide Kimura, Naoki Komatsu	Angewandte Chemie	2011	123 (6)	1424-1428
42	CNT-300 CNT-1000 CNT-2000	High-Performance Thin-Film Transistors with DNA-Assisted Solution Processing of Isolated Single-Walled Carbon Nanotubes	Yuki Asada, Yasumitsu Miyata, Yutaka Ohno, Ryo Kitaura, Toshiki Sugai, Takashi Mizutani, Hisanori Shinohara	Advanced Materials	2010	22 (24)	2698-2701
43	CNT-300 CNT-1000 CNT-2000	Chromatographic Length-Separation and Photoluminescence Study on DNA-Wrapped Single-Wall and Double-Wall Carbon Nanotubes	Yuki Asada, Toshiki Sugai, Ryo Kitaura and Hisanori Shinohara	Journal of nanomaterials	2009	2009	8

1. FAQ and Troubleshooting.....	166
(1) FAQ and Troubleshooting List	166
(2) FAQ	167
(3) Troubleshooting	174
2. Liquid Chromatography Basics.....	182
 (Technical Information)	
1. Preparation of Mobile Phase for HPLC	187
2. Inner Diameter of Column(scale down and scale up).....	189
3. Troubleshooting for Increased Pressure.....	191
4. Sample Pretreatment for HPLC.....	193
5. Baseline Noise in Gradient Elution	198
6. Effect of Guard Column	199
7. Selectivity of Packing Materials in Reversed Phase Liquid Chromatography	201
8. Methods in Developing Mobile Phase Condition for C ₁₈ Column	208
9. Comparison with Old Type COSMOSIL.....	213

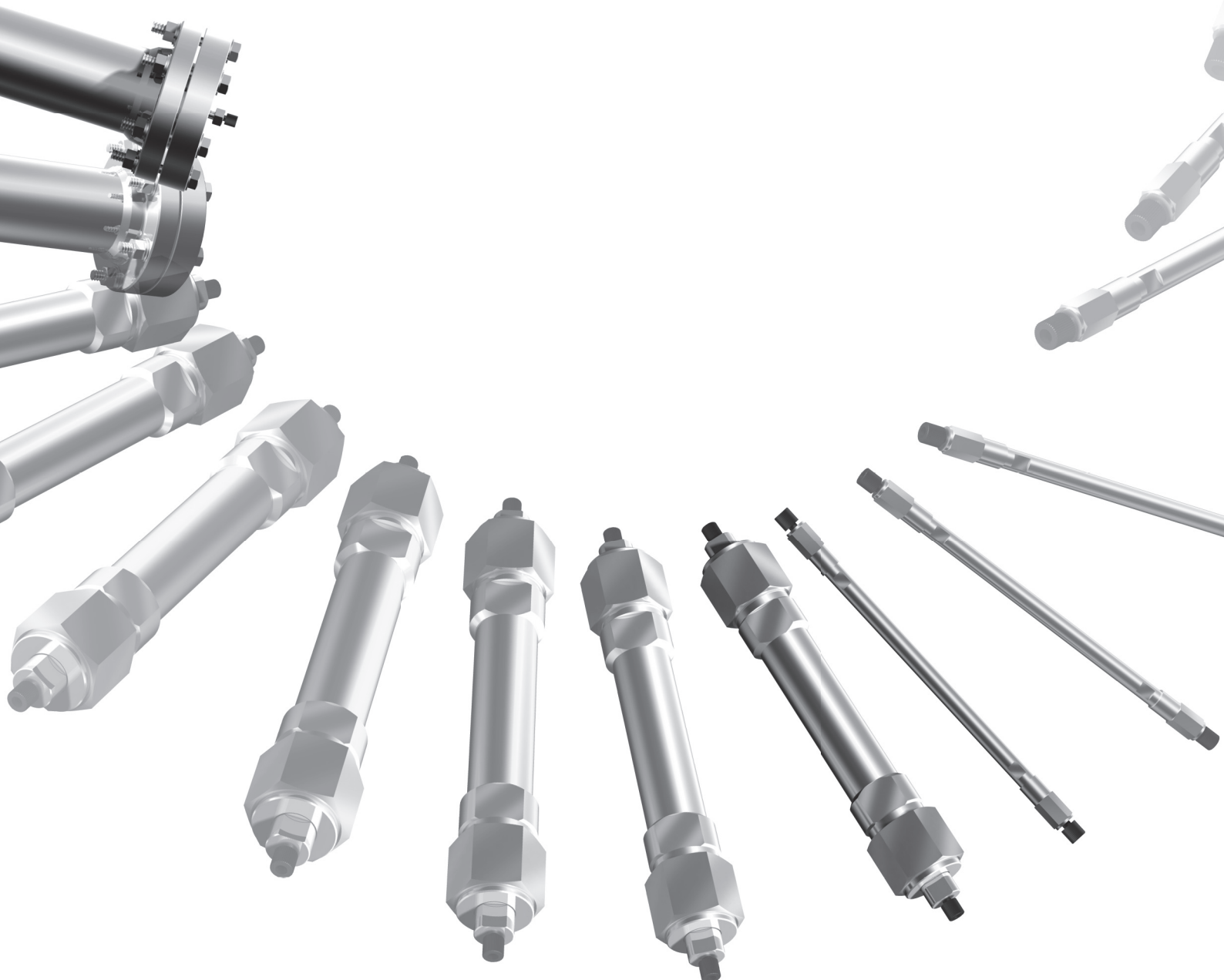

1.FAQ

(1) FAQ and Troubleshooting List

	• FAQ	Page	
I. HPLC Columns	Q1	What is the pressure limit of column?	
	Q2	What is the flow rate limit?	
	Q3	What is the recommended pH range?	167
	Q4	What is the concentration of buffer and salt?	
	Q5	How do I adjust mobile phase?	
	Q6	What solvent grade should I use for the mobile phase?	168
	Q7	What is the difference between acetonitrile and methanol?	
	Q8	Which mobile phase can be used for LC/MS or ELSD detector?	
	Q9	What should I pay attention to when I use ion-pairing reagents?	
	Q10	What flow direction should I use for the mobile phase?	169
	Q11	What is the recommended temperature range of columns?	
	Q12	What is the shipping solvent?	
II. UHPLC Columns	Q13	How do I wash columns?	
	Q14	How do I store columns?	170
	Q15	How long does a column last?	
	Q16	What happens when a column deteriorates?	
	Q17	How can I confirm the deterioration of column?	
	Q18	What should I pay attention to when I use semi-micro columns?	
	Q19	What should I pay attention to when I use UHPLC columns?	171
	Q20	How much sample can be loaded in a preparative column?	
	Q21	What should I pay attention to when I use both reversed phase and normal phase in the same instrument?	
III. Preparative Packing Materials	Q22	What is the connection type of column?	
	Q23	Which detection methods should I use?	172
	Q24	What is the common pressure unit?	
	Q25	What is dead volume?	
	Q26	What is the difference between column pre-filter and guard column?	
	Q27	How can I pre-treat samples?	173
	Q28	How can I choose internal standards?	
	IV. Related Products	• Troubleshooting	
T1		Poor peak shape	174
T2		Ghost peaks	175
T3		No peak	176
T4		Unstable base line	178
T5		Unstable retention time	179
T6		Increased column pressure	
T7		Unstable pump pressure	
T8		Poor resolution on C ₁₈ columns	180
T9		No retention on reversed phase columns	
T10		Excessive analysis time on reversed phase columns	
T11		Different separation performance compare to the past	
T12		Different separation performance with a new column	181
T13		Colored elute from columns (colorless of sample)	
T14	Air got inside the column (dried out)		
V. Applications	• Technical Notes		
	T1	Poor peak shape	174
	T2	Ghost peaks	175
	T3	No peak	176
	T4	Unstable base line	178
	T5	Unstable retention time	179
	T6	Increased column pressure	
	T7	Unstable pump pressure	
	T8	Poor resolution on C ₁₈ columns	180
	T9	No retention on reversed phase columns	
T10	Excessive analysis time on reversed phase columns		
VI. Technical Notes	T11	Different separation performance compare to the past	
	T12	Different separation performance with a new column	181
	T13	Colored elute from columns (colorless of sample)	
	T14	Air got inside the column (dried out)	
VII. Index			

(2) FAQ

Q1. What is the pressure limit of column?

Column	Pressure Limit	
UHPLC Column	COSMOSIL 2.5C ₁₈ -MS-II COSMOSIL 2.5Cholester COSMOSIL 2.5πNAP	30 MPa
CNT Column	COSMOSIL CNT Series	15 MPa or less
Other Column	Analysis Column (I.D.1.0-7.5 mm)	20 MPa or less
	Analysis Column (I.D.10.0 mm or more)	15 MPa or less

Attention;

A large pressure change may deteriorate columns even within the recommended pressure range.

Q2. What is the flow rate limit?

You can raise the flow rate under the pressure limits stated on Q1

Attention;

We recommend using standard flow rate described in the technical information 2 on page 189. Generally, higher column pressure corresponds to shorter column lifetime.

Q3. What is the recommended pH range?

Column	Recommended pH Range	
COSMOSIL (silica gel base) Series	COSMOSIL C ₁₈ -MS-II	pH 2-10
	COSMOSIL C ₁₈ -AR-II	pH 1.5-7.5
	Other Columns	pH 2-7.5
COSMOGEL (polymer base) Series	COSMOGEL IEX Series	pH 2-12

Attention;

Table above shows tolerant range for the packing material. Adjust the pH for ionic samples.

Q4. What is the concentration of buffer and salt?

Column	Buffer and Salt Concentration
Reversed Phase, Normal Phase, HILIC	Buffer concentration: 0.005-0.1 mol/l Additive concentration (trifluoroacetic acid, formic acid or acetic acid) : 0.1-1.0%
Ion Exchange	COSMOGEL IEX Series Buffer concentration: 0.02-0.1 mol/l Water miscible organic solvent concentration limit (e.g., methanol): 20% or less
Gel Filtration	COSMOSIL Diol Series Buffer concentration limit: 0.5 mol/l or less Salt concentration limit: 0.5 mmol/l or less
Hydrophobic Interaction	COSMOSIL HIC Buffer concentration limit: 0.5 mol/l or less Salt concentration limit: 2 mmol/l or less

Attention;

1. Insoluble compounds may clog columns. Filter buffers or salt solution before using.
2. Deposition of salt during analysis may deteriorate columns or equipments. Use the column under the concentration which salt does not precipitate.
3. Salt often precipitates when the organic solvent is mixed with the solution. Be careful when mixing mobile phases.
4. When equipment or a column contains organic solvent, replace mobile phase with salt-free mobile phase first before using salt-containing mobile phase.

Q5. How do I adjust mobile phase?

Please refer to Technical Information 1 on page 187.

Attention;

1. Adjust mobile phase ratio and buffer concentration exactly each time because concentration and pH may affect separation performance.
2. Degas the solvent after mixing.

Q6. What solvent grade should I use for the mobile phase?

We recommend using HPLC grade solvents, please refer to page 76.

Attention;

GR grade solvents are not suitable for gradient analysis or micro-scale analysis because they contain impurities that have ultraviolet adsorption causing unstable baseline or inaccurate detection. This is especially problematic in short wavelength (210–220nm). Antioxidant containing GR grade solvents (e.g., tetrahydrofuran, chloroform) may produce ghost peaks. GR grade trifluoroacetic acid may be chemically unstable and not recommended for HPLC.

Q7. What is the difference between acetonitrile and methanol?

Table below shows difference between acetonitrile and methanol

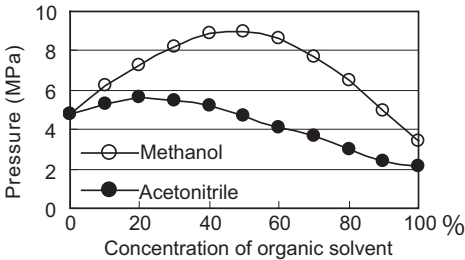
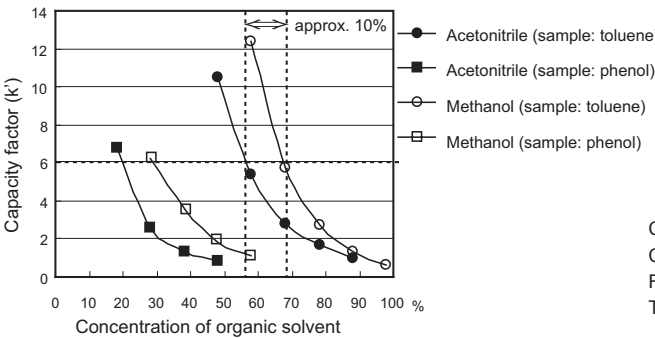
	Acetonitrile (for HPLC)	Methanol (for HPLC)
Pressure	 <p>Column 5C₁₈-MS-II Column size 4.6 mm I.D. x 150 mm Flow rate 1.0ml/min Temperature 30°C</p>	<p>Back pressure differs depending on species of organic solvents and mixing ratio. Back pressure of acetonitrile is lower than that of methanol at the same concentration.</p>
Elution Strength	 <p>Column 5C₁₈-MS-II Column size 4.6mm I.D.-150mm Flow rate 1.0ml/min Temperature 30°C</p>	<p>Elution strength of acetonitrile/water is stronger than methanol/ water at the same concentration. Within the range of about 30–80% in the concentration of the organic solvent, elution strength of acetonitrile/water is almost equivalent to that of methanol/water which was raised methanol concentration about 10% (e.g., acetonitrile : water = 60 : 40 → methanol : water = 70 : 30)</p>
Absorbance	Acetonitrile has a lower UV absorbance in far UV region (less than 250 nm) .	Methanol has a higher UV absorbance than acetonitrile in far UV region (less than 250 nm).
Degas of Mobile Phase	When acetonitrile is mixed with water, it is endothermic. It is difficult to degas.	When methanol is mixed with water, it is exothermic. It is easy to degas.

Q8. Which mobile phase can be used for LC/MS or ELSD detector?

Volatile solvent should be used for LC/MS detector or ELSD. Phosphoric acid buffer can not be used.

Reagent	Usable solvent / Additive
Solvent	Methanol, ethanol, acetonitrile, water and others
pH Adjusting Reagent	Acetic acid, formic acid, trifluoroacetic acid, ammonia water, ammonium acetate, ammonium formate and others
Ion Pair Reagent	Dibutylamine, triethylamine and others

Attention;

A small amount of non-volatile solvent, such as DMSO (dimethylsulfoxide) or DMF (dimethylformamide) can be used if they are mixed with methanol or acetonitrile. However, if the concentration becomes higher, detection sensitivity may decrease.

Q9. What should I pay attention to when I use ion-pairing reagents?

- Concentration of ion-pairing reagent should be 5–10 mmol/l.
- Use mobile phase of pH7 for acidic ion-pairing reagents and pH2.5 for basic ion-pairing reagents.
- Have enough equilibration time.
- Please refer to page 78 for choosing conditions.

Attention;

1. Higher ion pair concentration will result longer retention time.
2. Adjust pH of mobile phase so that sample is well ionized.
3. Need longer equilibration time compared to mobile phase without ion-pairing reagent.
4. Use a column exclusively with ion-pairing reagents since it is difficult to eliminate it from the column.

Q10. What flow direction should I use for the mobile phase?

Pump mobile phase through the direction specified on the column label.

Attention;

Pumping mobile phase in reverse direction may deteriorate packing material and decrease theoretical plates. Furthermore, impurities previously adsorbed on the column tip may loosen, causing contaminated detector, tubing, and noise.

Q11. What is the recommended temperature of columns?

The maximum temperature is 60°C, but the recommended temperature range is 20–50°C.

Attention;

1. Operating analysis at high temperature under alkaline or acidic condition may shorten column lifetime.
2. Maintain constant temperature during analysis as column temperature affects retention time. Generally, higher temperature lowers column pressure and shortens retention time.

Q12. What is the shipping solvent?

It depends on the column type. Please refer to the certificate of analysis inside the column box.

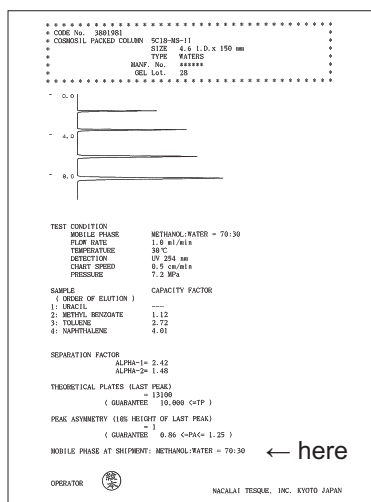

Q13. How do I wash columns?

1. How to eliminate buffer, salt or acid from a column?

Wash the column with solvent without buffer, salt or acid for 10–15 min. and store.

(E.g., When methanol : 20 mmol/l phosphoric acid buffer = 50 : 50 is used, wash with methanol : water = 50 : 50)

Attention;

If ratio of organic solvent and water is changed, salt may precipitate.

2. How to wash impurities in a column to achieve a stable base line?

Dissolve sample well, and use solvent with strong elution properties.

Type	Usable Solvent / Additive
Reversed Phase	(1) Sample is not protein Methanol or tetrahydrofuran Cleaning Solution Kit for Reversed Phase HPLC Columns (Product No. 08966–30) (2) Sample is protein 50–70% acetonitrile : water containing 0.1% trifluoroacetic acid. Attention; Some proteins may precipitate when concentration of organic solvent is high.
Normal Phase	Methanol, tetrahydrofuran, ethanol
Column for Fullerene Separation	1,2,4-trichlorobenzene and others
Sugar-D, NH ₂ , HILIC	Acetonitrile : water = 50 : 50 *Sugar-D and HILIC can be washed with 100% water.

Attention;

Do not use alkali solution (pH 7.5 or higher), which dissolve silica gel. Do not use strong acid solution (pH 1.5 or less) that may cleave bonded stationary phase.

3. How to eliminate impurities clogging the column entry end?

Pumping solvent through in a reversed direction at half the speed of ordinal analysis.

Attention;

Disconnect column from the detector during washing.

4. If column pressure is high, please refer to Technical Information 3 on page 191.

Q14. How do I store columns?

1. Store for short time (a few days)

Wash the column with solvent without buffer, salt or acid for 10–15 min. and store

(E.g., When methanol : 20 mmol/l phosphoric acid buffer = 50 : 50 is used, wash with methanol : water = 50 : 50)

2. Store for long time (one month or more)

Replace solvent with the following solvent to avoid fungus, dry and deterioration of column.

Column	Concentration of Buffer or Base
Reversed Phase	Storage Solution for Reversed Phase HPLC Columns (Product No. 08967–20) Methanol : water = 70 : 30, Acetonitrile : water = 70 : 30
Normal Phase	Halogen or acid-free organic solvent (hexane : ethanol = 90 : 10)
Ion Exchange Gel Permeation Hydrophobic Interaction	0.05% sodium azide solution and others
Column for Fullerene Separation	Toluene and others
Sugar-D, NH ₂ , HILIC	Acetonitrile : water = 70 : 30

Attention;

Store tightly plugged columns in a vibration-free, cool dark place.

Q15. How long does a column last?

Column life time may change depending on the operation condition (sample, concentration, salt, acid, pH of organic solvent)

Attention;

The most common cause of a short column lifetime is inadequate sample treatment. Please refer to Technical Information 4 on page 193.

Q16. What happens when a column deteriorates?

Common symptoms of column deterioration include increasing column pressure, decreasing theoretical plates, shortening retention time, worsening of peak shape and decreasing resolution.

Attention;

Please refer to Troubleshooting on page 174.

Q17. How can I confirm the deterioration of column?

Evaluate deterioration of column under the same condition as the attached "certificate of analysis that comes with the column". Use the same instrument every time to record the performance of the column. Record standard values over time and change to a new column if they are off.

Valued Item	Contents of Value
Capacity Factor (k')	If stationary phase is stripped, retention time may shorten.
Theoretical Plates (N)	It may decrease due to impurities or the state of packing material.
Peak Asymmetry (S)	It may decrease due to deterioration of packing material or adsorption of impurities.
Pressure	It may increase due to clogging of column filter, sample adsorption to packing material, compression of packing material and others.

(Reference value)

The following is reference value for 5C₁₈-MS-II (4.6 mm I.D. × 150 mm)

- Capacity factor (k') : 90% or less of Naphthalene's k'
- Theoretical plates (N) : 9000 or less
- Peak asymmetry (S) : out of range of 0.86–1.25
- Pressure : 20 MPa or more

Q18. What should I pay attention to when I use semi-micro columns?

Use injector, tubing and detector cell designed specifically for semi-micro column.

Attention;

Confirm linear mobile phase flow rate is in proportion to the column sectional area. For more information, please refer to Technical Information 2 on page 189.

Q19. What should I pay attention to when I use UHPLC columns?

- Use equipment for UHPLC.
- Shorten response of detector (e.g., 0.02 sec) when you use standard HPLC equipment.
- Use injector, tubing and detector cell designed for UHPLC columns.
- Column pressure should be 30 MPa or less.

Q20. How much sample can be loaded in a preparative column?

The sample load may differ depending on the sample resolution or solubility in mobile phase. Optimize maximum loading capacity by an analytical column, and determine maximum purified value in proportion to sectional area of column inner diameter.

Attention;

For scaling up from analytical column to preparative separation, please refer to page 35. For column inner diameter, flow rate and pipe, please refer to Technical Information 2 on page 189.

Q21. What should I pay attention to when I use both reversed phase and normal phase in the same instrument?

Replace solvent which both mobile phase can be mixed such as ethanol, then replace to new mobile phase.

Attention;

Mobile phase for reversed phase (e.g., methanol, water) and for normal phase (e.g., hexane) cannot be mixed.

Q22. What is the connection type of column?

Connection type of COSMOSIL and COSMOGEL is Waters type.

Attention;

Generally, waters type can be connected to most of instruments, but confirm the connection type with the manufacturer before using.

Q23. Which detection methods should I use?

Proper selection of a detector depends on the sample or the purpose of the experiment.

Detector	Feature
Ultra Violet Visible Detector (UV/VIS detector)	<p>[How to detect] Detect sample absorbance.</p> <p>[Sample] High sensitivity for compounds which have UV absorbance. Can not be used for compounds which do not have UV absorbance.</p> <p>[Feature] Easy, widely used.</p>
Fluorescence Detector (FLD)	<p>[How to detect] Detect fluorescence of photon excited sample.</p> <p>[Sample] Fluorescent sample</p> <p>[Feature] For sample which has little or no UV absorbance. High detection sensitivity enables trace component analysis.</p>
Refractive Index Detector (RI detector)	<p>[How to detect] Detect difference in index of refraction between sample and mobile phase.</p> <p>[Sample] All sample</p> <p>[Feature] For sample which has little or no UV absorbance (e.g., saccharides, alcohols, amino acids). Its disadvantages include sensitive to change of temperature, component of mobile phase and flow rate.</p>
Electro Chemical Detector (ECD)	<p>[How to detect] Detect electrochemically-active compounds such as oxidized or reducing compounds.</p>
Evaporative Light Scattering Detector(ELSD)	<p>[How to detect] Detect scattering light of microparticulated target compound by evaporating mobile phase.</p> <p>[Sample] Sample which has little or no UV absorbance (e.g., saccharides, alcohols, amino acids).</p> <p>[Feature] For sample which has little or no UV absorbance (e.g., saccharides, alcohols, amino acids). It is not applicable for low-boiling compounds.</p>
Mass Spectrometric Detector (MS Detector)	<p>[Feature] Able to measure MS spectrum of separated components for qualitative analyses. Disadvantage is compatible mobile phases are limited.</p>

Q24. What is the common pressure unit?

Most of unit is in SI unit, MPa

Attention;

Old equipment sometimes have different unit (conversion : 1 MPa = 10.197 kgf/cm²= 145.0 psi = 10 bar).

Q25. What is dead volume?

Dead volume is the follow path volume from injector to detector not relevant to resolution.

Attention;

1. If dead volume is large, sample may spread and have poor peak shape.
2. Choose proper injector, detector cell and tubing , and column inner diameter to minimize dead volume.

For inner diameter of tubing or cell, refer to Technical Information 2 on page 189.

Q26. What is the difference between column pre-filter and guard column?

(1) Column pre-filter (④)

Connect between pump and injector to eliminate solid impurities in mobile phase.

(2) Guard column (⑥)

Connect between injector and analytical column to eliminate adsorptions in sample.

Schematic Diagram of HPLC

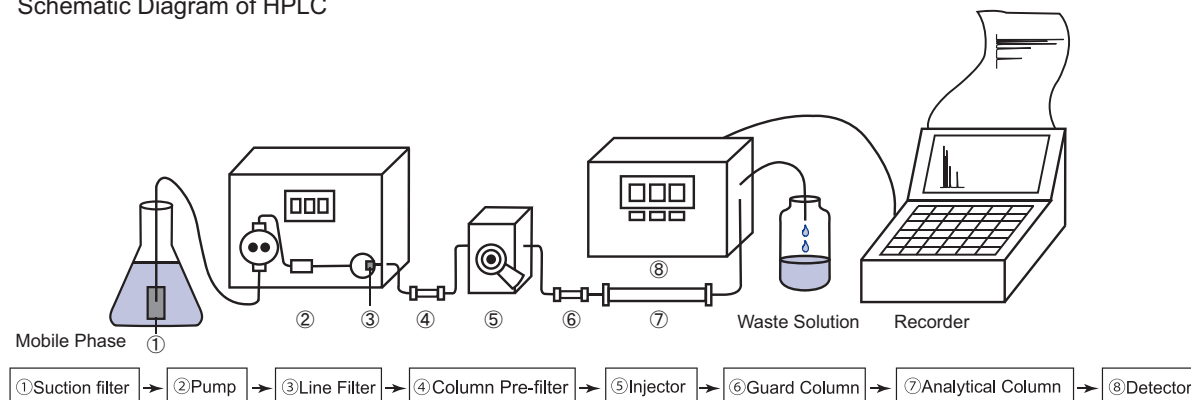

Q27. How can I pre-treat samples?

Refer to Technical information 4 on page 193.

Q28. How can I choose internal standards?

Ideal internal standards attribute,

- Peak of internal standards are near target compound peaks, but they do not overlap.
- Have no tailing or adsorption.
- Easy to procure at a low price.
- Have good chemical stability.

Methyl *p*-Hydroxybenzoate ~ Butyl *p*-Hydroxybenzoate is widely used in Japanese Pharmacopoeia.

(3) Troubleshooting

T1. Poor peak shape

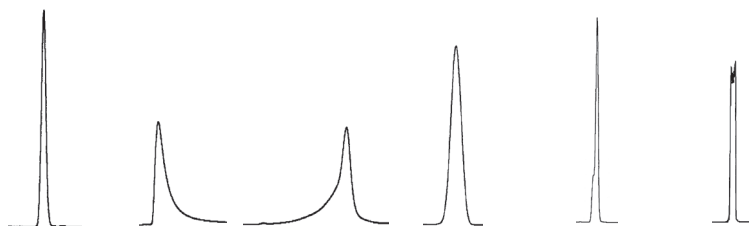

Normal Peak Tailing Peak Fronting Peak Broad Peak Peak Spike Peak Splitting

Symptom	Cause	Solution
Particular sample is tailing	Undesirable ion exchange interaction between basic compounds and packing material.	Replace the column with less residual silanols (C ₁₈ -MS-II). Or add 0.1-1% of acid to mobile phase.
	Undesirable coordinate interaction between metal coordination compound and packing material.	Add 5mmol/l of di-sodium dihydrogen ethylenediaminetetraacetate dihydrate (EDTA • 2Na) to mobile phase.
	Undesirable hydrogen bonding interaction between sample and packing material.	Change the organic solvent (e.g., acetonitrile to methanol).
All samples are tailing	Have spaces in packing material. Or column may have deteriorated.	Replace the column.
	(If the tailing does not improve after replacing the column) Sample is spreading out side of the column.	Reduce dead volume (Refer to Q25 on page 172 for more information on dead volume).
Fronting	Inject large volume of sample solvent that is significantly different in elution properties or pH comparing to mobile phase.	Dissolve sample in mobile phase. If the sample does not dissolve, dissolve in soluble solvent first, then dilute in mobile phase.
		Reduce injection volume to 1/2-1/10 Attention; Spikes or peak broadening may also occur.
Broad peaks 1 Sample has high molecular weight (MW: 2,000 or more).	Protein with high molecular weight cannot go into pores of packing material.	Use wide pore (pore size: 300A) column for reversed phase chromatography, COSMOSIL Protein-R. Refer to page 42 for more information.
	Sample volume is too large.	Reduce inject volume to 1/2-1/10. Attention; Tailing peaks may also occur.
	In case of broad tailing of a particular sample, compound may be adsorbed onto packing material.	Use COSMOSIL Protein-R, it has high recovery rate. Refer to page 42 for more information.
	In case of broad tailing of all samples, column may deteriorate.	Replace the column.
	Concentration of ammonium sulfate in sample solution is too low on hydrophobic chromatography (HIC).	Adjust concentration of ammonium sulfate to 1 mol/l or more.

Symptom	Cause	Solution
Broad peaks 2 Sample has low molecular weight (MW: 2,000 or less).	Sample volume is too large.	Reduce sample amount from 1/2 to 1/10. Caution; Tailing peaks may occur instead of broad peaks.
	In case of broad peak of a particular sample, compound may be adsorbed onto packing material.	Replace with a column that has a different packing material. (COSMOSIL 5C ₁₈ -MS-II is recommended for basic sample. The column has less adsorption to basic compounds. Please refer to page 14 for more information.)
	In case of broad peaks for all samples, the column may deteriorate.	Replace the column.
Peak spikes or peak splitting may occur for certain sample.	More than 2 samples are contained, and slightly separated.	Find the condition which enables separation of the two samples.
	Mobile phase and sample solvent are significantly different in their separation properties.	Dissolve sample in mobile phase. If sample does not dissolve, dissolve sample in sample soluble solvent first before mixing it with the mobile phase. Reduce loading capacity to 1/2 to 1/10.
	Mixed dissociated and non-dissociated ionic sample.	Adjust pH of mobile phase to pKa ± 2 or more of the ionic sample.
Peak spikes or peak splitting occur for all samples	Mobile phase and sample solvent are significantly different in their separation properties.	Dissolve sample in mobile phase. If sample does not dissolve, dissolve sample in sample soluble solvent first before mixing it with the mobile phase. Reduce loading capacity to 1/2 to 1/10.
	The column may have deteriorated.	Replace the column.

T2. Ghost peaks

Separation Mode	Cause	Solution
<Reversed Phase Chromatography> Use gradient elution method	Peaks from water impurities	Use new HPLC grade distilled water.
		Use a pre-column. Please refer to page 198 for more information.
<Reversed Phase Chromatography> Protein samples	Sample on previous analysis may be adsorbed onto the column, and elute on the next analysis.	Wash column, Please refer to page 170 for more information on washing methods.
		COSMOSIL Protein-R, which has high recovery rate for protein separations, is recommended. Please refer to page 42 for more information.
<All Separation Mode> Sample solvent and mobile phase are significantly different.	Sample solvent has peaks.	Dissolve samples in the same solvent as the mobile phase.
		Dissolve sample in mobile phase. If sample does not dissolve, dissolve sample in sample soluble solvent first before mixing it with the mobile phase.
<All Separation Mode> Mobile phase have peaks in blank analysis. (Peak area decreases with each injection.)	Injector is polluted	Wash column by injecting with a syringe of 20 ml solvent, e.g., methanol that can dissolve the pollutants
	Micro-syringe is polluted	Wash column with solvent e.g., methanol, chloroform or water to dissolve the pollutants. Ultrasonic cleaning is effective.
Others	Contamination or deterioration of samples	Adjust the sample again.
	Stabilizers in the mobile phase	Use HPLC grade solvent without stabilizers.

T3. No peaks

[How to confirm cause] Check t_0 first.

Analysis result of t_0	Cause
t_0 is not detected.	Detector may be defective.
Retention time of t_0 shifted.	Pump may be defective.
Retention time of t_0 is the same as usual.	Column may be defective.

• Solution for Each Column Type

Column Type	Cause	Solution
Reversed phase chromatography column	Sample is still in the column due to its high hydrophobicity.	Increase elution power of mobile phase until the sample elutes. e.g., 1. Increase concentration of methanol or acetonitrile (maximum 100%). 2. If the sample still does not elute, add 10–30% of higher elution organic solvent (e.g., tetrahydrofuran or chloroform) in methanol or acetonitrile (e.g., Tetrahydrofuran : methanol = 30 : 70).
	Metal coordination or basic compounds may be adsorbed onto the column.	Basic compounds may interact with residual silanols in the packing material. Use COSMOSIL 5C ₁₈ -MS-II, which has less residual silanols. Or add 0.1–1% of acid (e.g., trifluoroacetic acid, acetic acid) to the mobile phase. Metal coordination compounds may interact with a small amount of metal in the packing material. Add 5 mmol/l di-sodium dihydrogen ethylenediaminetetraacetate dihydrate (EDTA · 2Na) to mobile phase.
Normal phase chromatography column	Hydrophilicity of sample is too strong so that sample is still inside of column.	Increase elution power of mobile phase until the sample elutes. Replace with strong eluting solvent e.g., ethanol, or increase the concentration
	Metal coordination or basic compounds may be adsorbed onto the column.	Add 0.1–1% of acid (e.g., trifluoroacetic acid, acetic acid) to mobile phase.
Column for saccharides analysis (Sugar-D, NH ₂ -MS) or Hydrophilic chromatography column (HILIC)	For COSMOSIL 5NH ₂ -MS, sample is adsorbed to amino groups.	Use COSMOSIL Sugar-D with less undesirable adsorption.
	Sample is still in column because it is highly hydrophilic.	Increase concentration of water in mobile phase until the sample elutes. COSMOSIL Sugar-D or COSMOSIL HILIC is compatible with 100% aqueous mobile phase. COSMOSIL 5NH ₂ -MS is compatible with 50% water (e.g., acetonitrile : water = 50 : 50).
Gel filtration chromatography column (Diol)	Sample has ionic effect on silanol group.	To increase ionic strength in mobile phase, add approx. 0.3 mol/l of salt, e.g., sodium chloride
		Adjust mobile phase pH to 5.5 or less to prevent ionic interaction.
Hydrophobic chromatography column (HIC)	Sample may be adsorbed due to hydrophobic interaction.	Add 10–50% of organic solvent (e.g., acetonitrile) to mobile phase.
	Hydrophobicity of sample is too strong	Add 5% of organic solvent (e.g., methanol or acetonitrile).
	Sample may have ammonium sulfate precipitation before injection.	Decrease concentration of ammonium sulfate to 0.5mol/l or less until no precipitation is observed.

I. HPLC Columns

II. UHPLC Columns

Preparative
III. Packing Materials

IV. Related Products

V. Applications

VI. Technical Notes

VII. Index

- Defective Pump

Cause	Solution
Bubbles are generated in a pump.	Collapse bubbles (Please refer to T7 on page 180.).
Solvent leaking	Tighten connectors or replace tubings.

- Defective Detector

Cause	Solution
Detector is not connected correctly.	Follow the detector user's manual to connect correctly.
Defective signal from the detector	Contact detector manufacturer
UV adsorption range is not suitable for your sample.	Analyze at suitable UV adsorption for a sample. If the sample has no or little UV adsorption, use refractive index detector (RI detector) or evaporative light scattering detector (ELSD), or labeling the sample.

I. HPLC Columns

II. UHPLC Columns

III. Preparative Packing Materials

IV. Related Products

V. Applications

VI. Technical Notes

VII. Index

T4. Unstable base line

Cause	Solution
Impurities adsorbed onto a column previously are eluting out now.	Wash with strong eluting solvents (Please refer to Q13 on page 170.).
COSMOSIL PE-MS • π NAP • PYE • NPE • PBB-R • Cholester have UV absorption on stationary phase, and base line is not stable due to slight shedding (the detachment of stationary phase that has UV absorption.).	Wash with strong eluting solvents (Please refer to Q13 on page 170.).
Sudden change in the pump pressure may create bubbles.	Degas (Please refer to T7 on page 180.).
When using refractive index detector (RI detector)	
large temperature variations	Use thermostatic bath to keep a constant temperature. Beware of the air conditioner blowing on the RI detector or tubing. Caution; Cover equipment or tubing to avoid temperature fluctuation from an air conditioner.
Residual gas in mobile phase changes.	Degas (by ultrasonic wave or aspirator) a mobile phase.
Have needle-like peaks from an ultra violet visible detector	
Bubbles may be mixed in the column or detector.	Increase pressure to remove bubbles by blocking exit of the detector. Caution; Too much pressure may break the detector cell. If the problem persists, run thick solvent (e.g., 2-propanol) through for 15 min, disconnect the column from the detector.
Column temperature may be above the boiling point of mobile phase, creating bubbles in a column.	Analyze at suitable temperature. Basically, 20–50°C is suitable temperature for a column. Caution; To get the best result, analyze at 20–50°C lower than the boiling point of mobile phase (e.g., in case of Methanol [boiling point: 64.7°C], analyze at 45°C or less.).
When using ion-pair reagent for mobile phase or buffer.	
Inadequate equilibration of a column	Make equilibration time longer. When using ion-pair reagent for mobile phase or buffer, longer equilibration time is required compare to mobile phases without salt.
Salt may precipitate in the mobile phase and the mobile phase reservoir may become cloudy.	(a) Decrease concentration of buffer. (e.g., 100 mmol/l → 20 mmol/l) (b) Replace with a different buffer solution. (e.g., phosphoric acid buffer → acetic acid buffer) (c) Reduce concentration of organic solvent. (e.g., 70% acetonitrile : water = 70 : 30 → 50 : 50) (d) Replace with a different organic solvent. (e.g., acetonitrile → methanol)

I. HPLC Columns

II. UHPLC Columns

Preparative
III. Packing Materials

IV. Related Products

V. Applications

VI. Technical Notes

VII. Index

T5. Unstable retention time

• Cause by Equipments

Equipment	Cause	Solution
Pump	Bubbles in the check valve of pump.	Degas (Please refer to T7 on page 180.). Normal phase solvents have lower boiling point, so bubbles are easily created. Furthermore, its low-viscosity prevents bubbles from eluting.
	Solvent leaking	Tighten the leaking part. If the problem does not solve, replace it.
Thermostatic Bath (for adjusting temperature)	Column temperature may vary by season or the time of day without the use of thermostatic bath or column oven.	Use thermostatic bath or column oven to keep consistent column temperature. Caution; Set thermostatic bath or column oven to 5°C above the room temperature when doing room-temperature analyses.

• Cause by Columns

Column Type	Cause	Solution
Reversed Phase Column	Inadequate column equilibration when using ion pairing reagents.	Make equilibration time longer. When using ion-pair reagents, longer equilibration time is often required.
	If 100% water is used as mobile phase on C ₁₈ column, phase collapse may occur.	COSMOSIL C ₁₈ -PAQ is compatible with 100% aqueous mobile phase (Please refer to page 18.). Caution; For unstable retention time, wash the column with high organic solvents (e.g., methanol : water = 70 : 30) to recover.
Normal Phase Column	A small amount of water in organic solvent may affect retention time.	Replace with mobile phase without water. If sample solvent has water, change sample solvent or decrease the injection volume. If water is trapped, wash with ethanol to recover.
Columns for Saccharide Analysis (Sugar-D, NH ₂ -MS) or Hydrophilic Chromatography column(HILIC)	A small amount of stationary phase detached.	COSMOSIL Sugar-D or COSMOSIL HILIC can be recovered by washing with 100% water for 15 minutes. COSMOSIL 5NH ₂ -MS may be recovered by washing with 50% water (e.g., acetonitrile : water = 50 : 50) for 15 minutes.

T6. Increased column pressure

Please refer to Technical Information 3 on page 191.

T7. Unstable pump pressure

Cause	Solution
Bubbles in the check valve of a pump.	Degas the check valve (open drain valve, and let mobile phase through) according to the pump instruction. If the problem persists, wash check valve, e.g., ultrasonic cleaning in water.

Caution;

1. If the bubbles occur often in normal phase chromatography, connect pre-column to increase pressure, and let bubbles elute.
2. Degas a mobile phase by a ultrasonic or an aspirator.

T8. Poor resolution on C₁₈ columns

Solution	Features
Use a longer column	A longer column enables sharper peaks. The pressure will increase and the retention time will be longer.
Change mobile phase condition (e.g., pH, type or concentration of organic solvent)	Experience or knowledge is required. Do not set complicated condition as it lacks repeatability.
Use packing material with non-hydrophobic interactions.	Separate sample by molecular shape selectivity or π - π interaction (except for hydrophobic interaction). Please refer to Technical Information 7 on page 201 for more information on special column with various interactions.

T9. No retention on reversed phase columns

Solution	Features
Use ion pair reagents	Ion pair reagents enable separation by forming ion pairs with the sample to increase hydrophobicity. Therefore, it is not applicable for non-dissociative samples.
Use hydrophilic columns (HILIC). Please refer to page 36.	Less hydrophobic samples are retained longer.

T10. Excessive retention time is long on reversed phase columns

Solution	Features
Use the gradient elution method	Gradient elution method shortens analysis time by changing organic solvent concentration during analysis. Disadvantages are having a capable equipment, increasing baseline, and the need for equilibration time between each runs.
Use UHPLC Columns	Please refer to page 62, for more information.
Change mobile phase condition	Problem may be solved by changing pH, type or concentration of organic solvent.
Use column with small hydrophobicity	COSMOSIL CN-MS is recommended. Please refer to page 31, for more information.

T11. Different separation performance compare to the past

Symptom	Cause	Solution
Decreased theoretical plates	Natural deterioration of the packing material	No method to recover column.
Decrease of retention time or separation.	Impurities may be adsorbed onto the packing material.	The column can be recovered by washing
	Stationary phase shedding.	No method to recover column.

T12. Different separation performance with a new column

Cause	Solution										
Analytical condition does not suit to sample	Adjust pH of mobile phase to pKa \pm 2 or more. Use mobile phase with high repeatability.										
Column may deteriorate	If the column deteriorate, decrease of retention time, change of peak shape may occur. Replace the column.										
Variation from lot to lot	Contact us with the column name, product no, present separation status. (a) Evaluate columns with 3 different packing material lots. We provide validated column with 3 different packing material lots for the following columns (Size 4.6 x 150 mm, 3 pkg set). Contact us for more information. <table border="1" data-bbox="667 846 1034 1016"> <thead> <tr> <th>Packing material</th> <th>Product No.</th> </tr> </thead> <tbody> <tr> <td>COSMOSIL 5C₁₈-MS-II</td> <td>09397-73</td> </tr> <tr> <td>COSMOSIL 5C₁₈-AR-II</td> <td>09396-83</td> </tr> <tr> <td>COSMOSIL Cholester</td> <td>07970-03</td> </tr> <tr> <td>COSMOSIL HILIC</td> <td>09385-23</td> </tr> </tbody> </table> (b) Find an analysis condition with less influence from lot-to-lot variation.	Packing material	Product No.	COSMOSIL 5C ₁₈ -MS-II	09397-73	COSMOSIL 5C ₁₈ -AR-II	09396-83	COSMOSIL Cholester	07970-03	COSMOSIL HILIC	09385-23
Packing material	Product No.										
COSMOSIL 5C ₁₈ -MS-II	09397-73										
COSMOSIL 5C ₁₈ -AR-II	09396-83										
COSMOSIL Cholester	07970-03										
COSMOSIL HILIC	09385-23										
Cause is not column (e.g., mobile phase, flow rate, temperature)	Find the cause.										

T13. Colored elute from columns (colorless sample)

Cause	Solution
A small amount of shedding, impurities or previous samples.	Wash column with strong elution solvent (e.g., methanol) or use cleaning solution kit for reversed phase HPLC columns (Product No. 08966-30)

Caution;

A small amount of stationary phase does not affect retention time.

T14. Air got inside the column (dried out)

Pump solvent with low viscosity (e.g., methanol) through at half of analysis flow rate for 1 hour.

Caution;

Store it tightly plugged in a cool dark place.

2. Liquid Chromatography Basics

History of Liquid Chromatography

Liquid chromatography was defined by Mikhail S. Tswett (1906–1907) who separated leaf pigments into different colored bands using chalk powder (CaCO_3) as adsorbent. Then reversed phase chromatography, ion exchange chromatography, size exclusion chromatography were developed. In 1971 J.J. Kirkland has succeeded in the production of chemically bonded packing material for liquid chromatography, and contributed to establish the basics of high-performance liquid chromatography, which are now one of the most important analysis methods.

HPLC Equipments

HPLC equipments are connected as shown in Figure 1 in the order of mobile phase flow from mobile phase reservoir, pump, injector, column, detector to waste solvent container. Samples are introduced into mobile phase through the injector and separated by the column. Chromatogram is drawn by recorder.

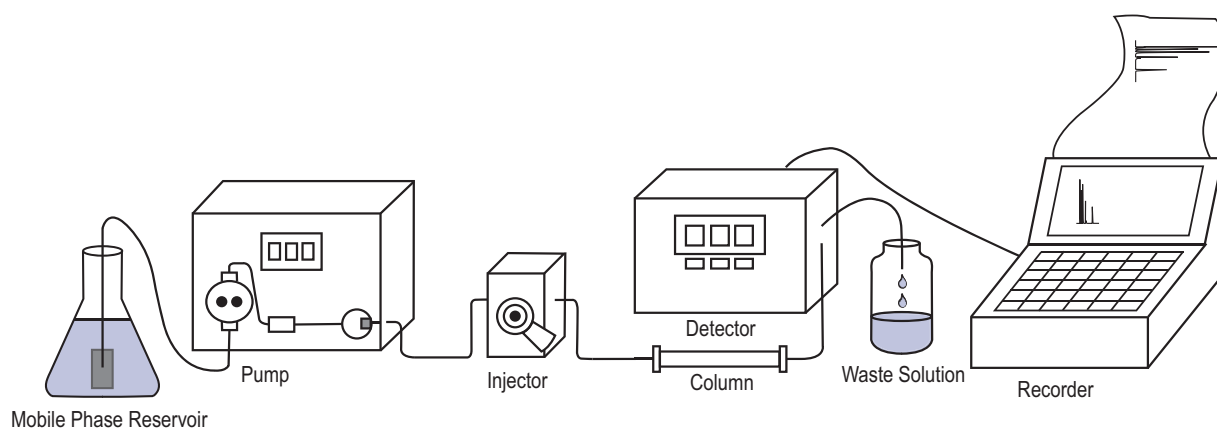

Figure 1 HPLC Equipments

- **Mobile Phase Reservoir**
Glass bottle or conical flask is used as a mobile phase reservoir. To avoid clogging from insoluble compounds in the mobile phase, a suction filter (or sinker) is attached to the inlet.
- **Pump**
Send mobile phase at a consistent flow rate or pressure. Connecting two pumps enables gradient elution.
- **Injector**
Inject sample to column by a micro-syringe. Auto-injector is widely used for automated sample injection.
- **Column**
Packing material is packed in a stainless or glass chromatogram column. To avoid the elution of packing material, a frit ($2\ \mu\text{m}$) is packed on each end of the column.
- **Column Thermostatic Oven**
Maintain the column at a consistent temperature. Temperature control is very important for reversed phase chromatography and ion exchange chromatography. It is desirable to keep the temperature within $\pm 0.5^\circ\text{C}$. Water or air circulator is widely used.
- **Detector**
Detect each compounds eluted from the column, and convert them into electronic signals.
- **Recorder**
Process the electronic signals from detector to draw chromatograms. Retention time, peak area, and theoretical plate numbers are automatically calculated.

Chromatogram

Elution means the process to extract retained samples from a column. Retention time means the time between the sample injection and the sample extraction. Chromatogram is a two-dimension diagram (Figure 2) that reveals the retention time on the abscissa and the concentration of solute on the ordinate. The chromatogram shows following data.

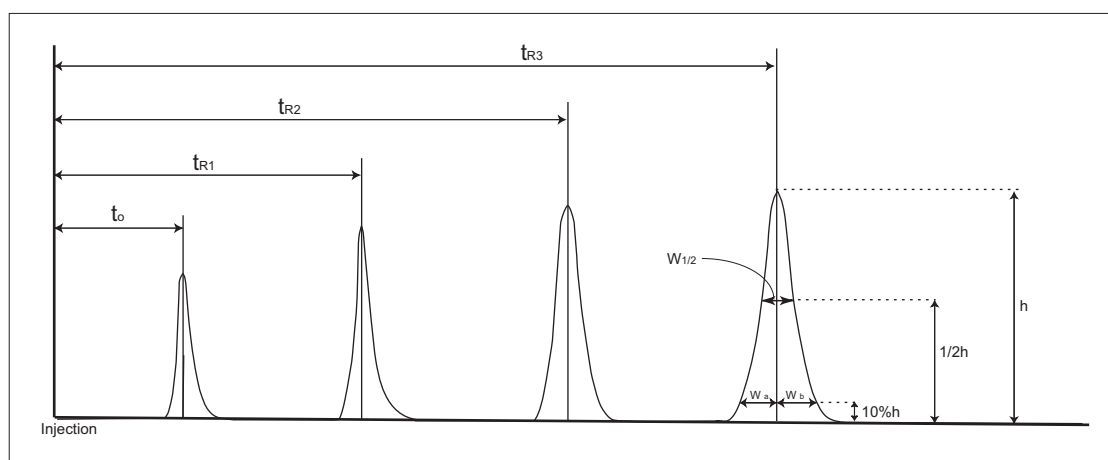

Figure 2 Chromatogram

(1) t_0 : Retention time of the mobile phase

The retention time of an unretained peak. Uracil is widely used in reversed phase as a t_0 marker.

(2) t_R : Retention time

Distance from the point at peak midpoint to the start of analysis.

(3) h : Peak height

Distance from the peak top perpendicular to the baseline.

(4) $W_{1/2}$: Peak half width

The peak width at half height

(5) k' (capacity factor) : Capacity factor, retention ratio of each sample, $k' = (t_R - t_0) / t_0$

A higher volume means longer retention. . The value remains consistent under the same experimental condition (packing material, mobile phase and temperature)

(6) N (theoretical plate) : theoretical plate number, $N = 5.54 (t_R / W_{1/2})^2$

A theoretical plate is an imaginary layer within a column that helps to interpret the separation process. A higher theoretical plate number corresponds to better column efficacy. The plate number depends on the packing material and experimental conditions.

(7) S (peak asymmetry) : peak asymmetry, $S = W_b / W_a$

W_a : Distance from the leading edge of the peak to the midpoint (measured at 10% of peak height)

W_b : Distance from the point at peak midpoint to the trailing edge (measured at 10% of peak height)

The peak asymmetry $S=1$ indicates a perfectly symmetrical peak, and $S > 1$ indicates tailing, and $S < 1$ indicates leading. Tailing or leading occurs with deteriorated packing material, unsuitable experimental conditions or overloading.

(8) α (separation factor) : Separation factor, $\alpha = k'_2 / k'_1$ (k'_1 and k'_2 : retention ratio of each sample)

The separation factor must be > 1 for peak separation. A higher α value indicates greater distance between the peaks.

(9) R_s (resolution) : Resolution, $R_s = \frac{\sqrt{N}}{4} \cdot \left\{ \frac{\alpha - 1}{\alpha} \right\} \cdot \left\{ \frac{k'_2}{1 + k'_2} \right\}$

The resolution (R_s) indicates how well two samples are separated. $R_s=1.5$ indicates baseline separation. If the R_s value is smaller than 1.5, peaks may overlap.

Features of Each Separation Mode of HPLC

HPLC has following separation modes.

• Normal Phase Chromatography

Adsorbent material such as silica gel or alumina is used as the packing material. Analytes are separated by the difference in adsorptive forces to the packing material, resulting in each moving at different speed. The analyte that interacts more strongly with the packing material moves at a slower rate.

• Reversed Phase Chromatography

Analytes are distributed between polar mobile phase and non-polar stationary phase, and separated by the flow speed difference due to the difference in the distribution between these two phases. If the analyte distributes more to the stationary phase, it would have a slower flow speed. Non-polar packing materials, such as octadecyl group and octyl group bonded silica gels are widely used. They are stable to heat and hydrolysis within a certain pH and temperature range, separation is influenced by the type of stationary phase, carbon rate, end capping treatment, etc.

• Ion-exchange Chromatography

Charged functional groups are bonded to the solid support to separate ionic solutes with the counter-ions. Analytes are separated by the flow speed difference due to the difference in the affinity to stationary phase. Dextran, cellulose and polystyrene are commonly used as the packing materials. Typical functional groups are Sulfopropyl (SP) and Carboxymethyl (CM) for cationic exchange, and Diethylaminoethyl (DEAE) and Quarternary ammonium (QA) for anionic exchange. The ion exchange capacity which influences separation performance depends on the type and density of the functional groups.

• Size Exclusion Chromatography

Analytes are separated by the molecular size. The analyte smaller than the pore size can penetrate the pores and migrate slowly, whereas larger analyte is excluded from the pores and migrates quickly. This mode mainly used for separation of high molecular polymer (molecular weight 2,000 and more). Organic expanded type gels (such as dextran and polyacrylamide) and inorganic gels (such as silica gel and glass) are used as packing materials.

Separation Mechanism of HPLC

The most common mode, reversed phase is used as an example here. Mixed samples are injected into a column, the lower hydrophobic analyte (A) distributes in the polar mobile phase and move faster down the column. Conversely, higher hydrophobic analyte (B) distributes in the non-polar stationary phase for a longer time and moves slower down the column. Therefore, the analytes flow out of the column in order of the polar first and the non-polar last.

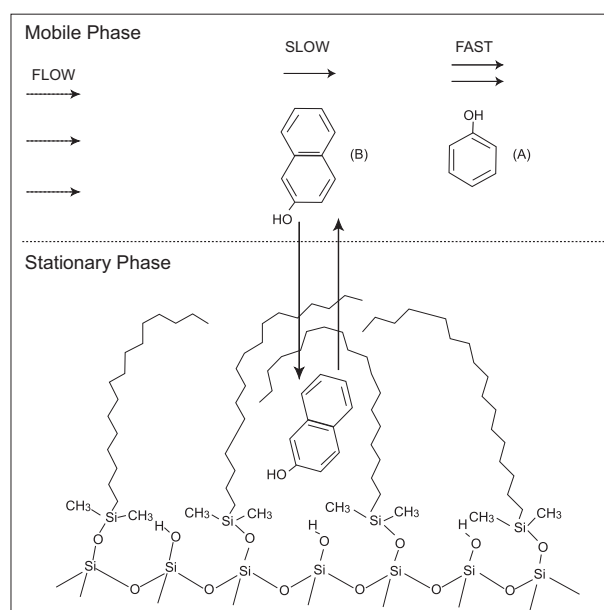

Figure 3. Separation Mechanism

Mobile Phase Solvent

The important mobile phase qualities for HPLC are shown below.

1. High solubility for the sample components
2. Good miscibility
3. No detection disturbance
4. Low viscosity
5. Higher boiling point than the operational temperature
6. Low toxicity and non-flammability
7. Low price
8. Using HPLC grade or filtered solvents.

Next, selection guide of mobile phase is shown below according to the separation mode.

● Normal Phase Chromatography

Generally, a polar solvent is mixed with a nonpolar solvent. The separation factor is adjusted by changing the mixed ratio. Please refer to the polarity and the solubility of solvent. Toluene, hexane, chloroform, ethyl acetate, and ethanol are mainly used.

● Reversed Phase Chromatography

Water, methanol, acetonitrile, and tetrahydrofuran are mainly used. Separation factor is adjusted by the mixed ratios of these solvents. When using silica-based columns for ionic analytes, it is desirable to adjust the pH range from 2 to 7.5. Generally, silica-based columns are not stable outside of this range due to cleavage of the bonded groups at $\text{pH} < 2$, and the dissolution of silica support at $\text{pH} > 7.5$. Use filtered phosphoric acid buffer solution or acetic acid buffer solution for pH control.

● Ion-exchange Chromatography

Add buffer solution in water and adjust separation factor by salt concentration (ionic strength) and pH. The more ionic strength is, the earlier the sample elutes. Lower pH decreases the separation factor on anion exchange, and increases the one on cation exchange. Cation buffer solutions, such as ammonia and amine are used for anion exchange, and anion buffer solutions, such as acetic acid salt, formic acid salt and citric acid are used for cation exchange.

● Size Exclusion Chromatography

Generally, a single solvent is used as the mobile phase, and it is not changed to adjust the separation factor. Tetrahydrofuran, chloroform, toluene and dimethylformamide are commonly used in non-aqueous mode. Add buffer solution in water for aqueous mode. Adjust pH and ionic strength to prevent adsorption and other undesired interactions.

Quantitative Analysis

Absolute calibration curve method or internal standard method is used to calculate the amount or concentration of solute by peak area or height.

● Absolute Calibration Curve Method

1. Prepare the standard solutions in 3–4 different concentrations.
2. Inject the same volume of each standard solution, record chromatogram, and measure peak area.
3. Prepare a calibration curve by plotting the amounts of the standard on the x-axis and the peak areas on the y-axis. The calibration curve is usually a straight line through the origin.
4. Inject sample under the same conditions as the standards, and record a chromatogram. Measure the peak area (y) and use the calibration curve to determine the sample amounts.

This method should be performed exactly under a given condition. This method is also called external standard method.

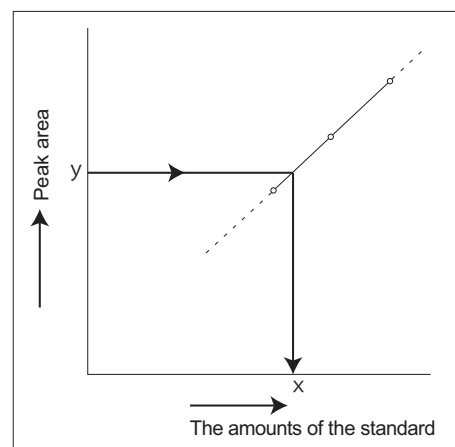

Figure 4. Absolute calibration curve

● Internal Standard Method

1. Prepare 3–4 known concentration^{*1} ratios of the standards and samples^{*2}.
2. Inject a constant volume of each concentration, record chromatogram and measure peak areas.
3. Prepare a calibration curve (as shown on fig. 5) by plotting M_x/M_s vs. A_x/A_s ratios. M_x is the amount of the sample injected, and M_s is the amount of the standard. A_x is the peak area of the sample, and A_s is the peak area of the standard. The calibration curve is usually a straight line through the origin.
4. Then, prepare a the test solution containing a known amount of the internal standard and an unknown amount of sample^{*3}. Perform the experiment under the same conditions as for obtaining the calibration curve.
5. Use the calibration curve to determine the unknown sample amount.

*1 If the calibration curve is confirmed to be a straight line through the origin, plot the calibration curve with A_x/A_s determined by one point of concentration of injected unknown sample.

*2 The internal standard should have similar chemical characters as the sample while completely separated from it.

*3 When the internal standard is added to the test solution, make sure the chemical reaction (e.g., precipitation) does not occur.

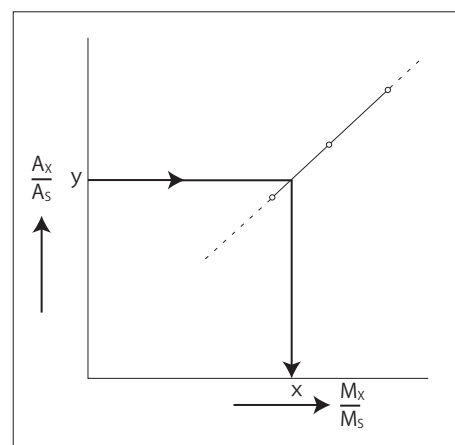

Figure 5. Calibration Curve of Internal standard method

1. Preparation of Mobile Phase for HPLC

1) Organic Solvent / Aqueous Mixed Mobile Phase

(e.g.) Methanol : Water = 70 : 30 1L

Prepare mobile phase by volume ratio.

1. Measure 700 ml of methanol in a measuring cylinder.
2. Measure 300 ml of distilled water in a measuring cylinder.
3. Mix 1 and 2 thoroughly and degas.

Attention; The better approach is to prepare the mobile phase gravimetrically rather than volumetrically. Following is example of preparation.

Composition table for mobile phase 1L (Methanol : water)

Methanol / Water	Methanol (g)	Distilled Water (g)
90 : 10 (v/v)	711.9	99.8
80 : 20 (v/v)	632.8	199.6
70 : 30 (v/v)	553.7	299.5
60 : 40 (v/v)	474.6	399.3
50 : 50 (v/v)	395.5	499.1
40 : 60 (v/v)	316.4	598.9
30 : 70 (v/v)	237.3	698.7
20 : 80 (v/v)	158.2	798.6
10 : 90 (v/v)	79.1	898.4

Composition table for mobile phase 1L (Acetonitrile : water)

Acetonitrile / Water	Acetonitrile (g)	Distilled Water (g)
90 : 10 (v/v)	707.4	99.8
80 : 20 (v/v)	628.8	199.6
70 : 30 (v/v)	550.2	299.5
60 : 40 (v/v)	471.6	399.3
50 : 50 (v/v)	393.0	499.1
40 : 60 (v/v)	314.4	598.9
30 : 70 (v/v)	235.8	698.7
20 : 80 (v/v)	157.2	798.6
10 : 90 (v/v)	78.6	898.4

Caution : Methanol and acetonitrile are hazardous substances, do not use for medical purpose. Always process in a laboratory hood and wear an eye protection and a mask.

(Reference) Influence of organic solvent composition in mobile phase on the retention time.

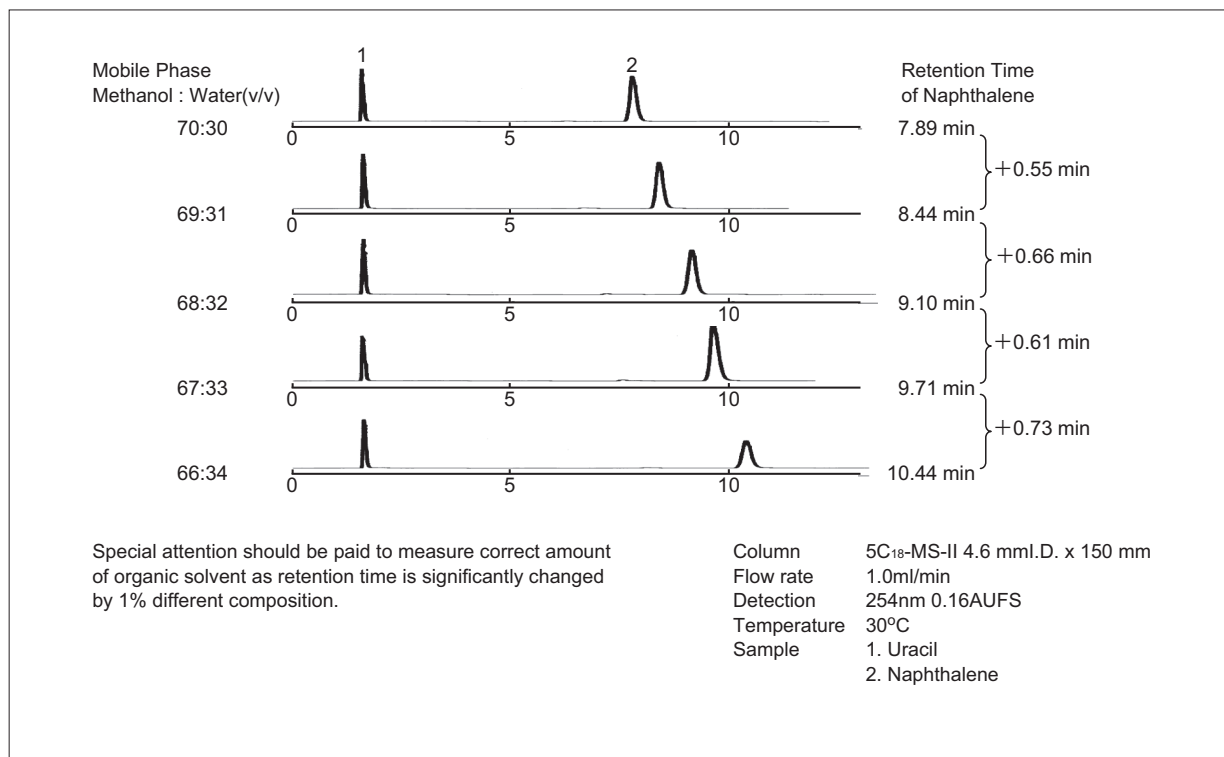

2) Organic Solvent / Buffer Mixed Mobile Phase

(e.g.1) Preparation of 20 mmol/l phosphate buffer (pH2.5)

1. Preparation of 20 mmol/l sodium dihydrogenphosphate aqueous solution (Dissolve 2.40g of sodium dihydrogenphosphate, Anhydrous (Product No. 31720-65) in distilled water to make 1L solution.)
2. Prepare 20 mmol/l phosphate aqueous solution (Dissolve 2.31g of Phosphoric acid (Purity: 85%), (Product No. 08964-92) in distilled water to make 1L solution.).
3. Adjust the pH to 2.5 by mixing 1 with 2.
4. Filter under reduced pressure to remove insoluble substance (0.45 μm or smaller pore size is recommended.). Attention; Filter solids from the solution to prevent clogging to pump and columns.
5. When mix with organic solvent, mix by volume ratio.
Attention; The solid may precipitate after mixing.

For more information on adjusted solution, Phosphate Buffer Solution (pH 2.5) (5x) (Product No, 08969-71), Please refer to page 77.

(e.g.2) Preparation of 20 mmol/l phosphate buffer (pH7.0)

1. Preparation of 20 mmol/l sodium dihydrogenphosphate aqueous solution (Dissolve 2.40 g of sodium dihydrogenphosphate, Anhydrous (Product No. 31720-65) in distilled water to make 1L solution.)
2. Prepare 20 mmol/l di-sodium hydrogenphosphate aqueous solution (Dissolve 2.84 g of di-Sodium Hydrogenphosphate, (Product No. 31801-05) in distilled water to make 1L solution.).
3. Adjust the pH to 7 by mixing 1 with 2.
4. Filter under reduced pressure to remove insoluble substance (0.45 μm or smaller pore size is recommended.). Attention; Filter solids from the solution to prevent clogging to pump and columns.
5. When mix with organic solvent, mix by volume ratio.
Attention; The solid may precipitate after mixing.

For more information on adjusted solution, Phosphate Buffer Solution (pH 7.0) (5x) (Product No, 08968-81), Please refer to page 77.

(e.g.3) Preparation of 5 mmol/l Sodium 1-hexanesulfonate, 20 mmol/l phosphate buffer (pH2.5)

1. Prepare 5 mmol/l Sodium 1-hexanesulfonate, 20 mmol/l phosphate buffer (pH2.5) aqueous solution (Dissolve 10 ml of Sodium 1-hexanesulfonate (0.5 M solution) (Product No. 31532-06) and 2.40 g of sodium dihydrogenphosphate, Anhydrous (Product No. 31720-65) in distilled water to make 1L solution.).
2. Prepare 5 mmol/l Sodium 1-hexanesulfonate, 20 mmol/l phosphate aqueous solution (Dissolve 10 ml of sodium 1-hexanesulfonate (0.5 M solution) (Product No. 31532-06) 2.31g of phosphoric acid (Purity: 85%), (Product No. 08964-92) in distilled water to make 1L solution.).
3. Adjust the pH to 2.5 by mixing 1 with 2.
4. Filter under reduced pressure to remove insoluble substance (0.45 μm or smaller pore size is recommended.). Attention; Filter solids from the solution to prevent clogging to pump and columns.
5. When mix with organic solvent, mix by volume ratio.
Attention; The solid may precipitate after mixing.

2. Inner Diameter of Column (scale down and scale up)

Introduction

The figure below shows general parameters for 1.0 mm to 50 mm I.D. COSMOSIL columns : flow rate, equipment, inner diameter of pipe, application, surface ratio (compared with 4.6 mm I.D.) and particle size. It may help to scale up or down from the most commonly used 4.6 mm I.D. column.

Inner Diameter (mm I.D.)	1.0	2.0	3.0	4.6	10	20	28	50
Flow Rate (ml/min)	0.05	0.2	0.4	1.0	5.0	19	37	70
Detector Cell • Injector	for Semi-micro		for Analytical			for Preparative		
Inner Diameter of Pipe (mm)	0.05	0.1	0.2-0.3			1.0		
Application	LC-MS Solvent saving		Solvent saving with standard system	Standard	Preparative (small scale)	Preparative (medium scale)	Preparative (large scale)	Preparative (super large scale)
Surface Ratio with 4.6 mm I.D.	0.05	0.19	0.43	1.00	4.73	18.90	37.05	118.15
Particle Size (µm)	3 or 5			5		15 or more		

Scale Down

When scaling down from the most commonly used analytical column (4.6 mm I.D.) to a semi-micro or 3.0 mm I.D. analytical HPLC column (of the same column length), sample loading dose is proportionate to the cross section of column. The 3.0 mm I.D. columns provide high sensitivity and solvent saving without the need to change the existing equipment settings. Semi-micro columns (2.0 mm I.D. and 1.0 mm I.D.) provide higher sensitivity and enable analysis of minor components, but one needs to change the piping of HPLC equipment, the injector and the detector cell for semimicro columns.

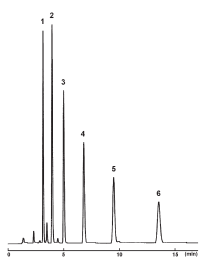
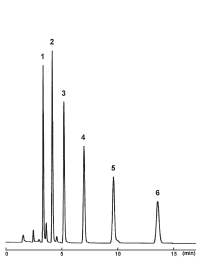
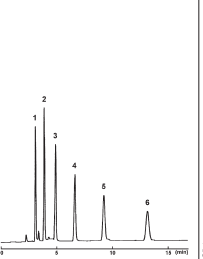
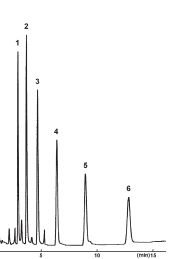
Column Size	4.6 mm I.D. x 150 mm	3.0 mm I.D. x 150 mm	2.0 mm I.D. x 150 mm	1.0 mm I.D. x 150 mm
Chromatogram				
Flow Rate (ml/min)	1.0	0.4	0.2	0.05
Pressure (MPa)	3.4	3.6	3.8	3.6
Injection Volume (µl)	1.0	0.4	0.2	0.05
Detector Cell • Injector	for Analytical		for Semi-micro	
Detector sensitivity (AUFs)	0.08		0.04	
Inner diameter of pipe (mm)	0.25		0.10	0.05

Column COSMOSIL 5C₁₈-MS- II
 Mobile Phase Acetonitrile : Water = 70 : 30
 Flow Rate 1.0 ml/min
 Temperature 30°C
 Detection UV 254 nm

Sample
 1. Benzene
 2. Toluene
 3. Ethylbenzene
 4. Propylbenzene
 5. Butylbenzene
 6. Amylbenzene

Scale Up

When scaling up from analytical column (4.6 mm I.D.) to preparative column (of the same packing material (particle size) and length), sample loading capacity is proportionate to the cross section of column.

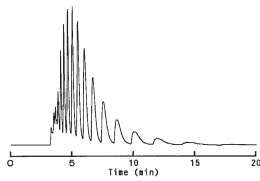
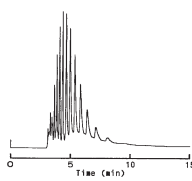
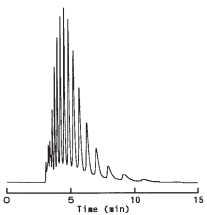
Column Size	4.6 mm I.D. x 250 mm	10 mm I.D. x 250 mm	20 mm I.D. x 250 mm
Chromatogram			
Flow Rate (ml/min)	1.0	5.0	18.9
Pressure (MPa)	5.5	5.9	5.8
Injection Volume (μl)	125	625	2,500
Detector Cell • Injector	for Analytical		Preparative
Inner Diameter of Pipe (mm)	0.25		1.0

Column COSMOSIL 5SL-II
 Mobile Phase Ethyl Acetate : Ethanol = 4 : 1
 Temperature 30°C
 Detection UV 254 nm
 Sample Triton X-100

Comparison of Particle Size

When change particle size of packing material from 5 μm to 15 μm, the number of theoretical plate (N) is reduced by one-third, and the pressure is reduced by one-ninth. As shown in the figure below, when a small amount of sample is injected, there is a big difference in the number of theoretical plates between 5 μm and 15 μm. However, when a large amount of sample is injected, there is not much difference between the two. Therefore, the low pressure packing material (particle size 15 μm) is recommended for preparative column (28 mm I.D. or more).

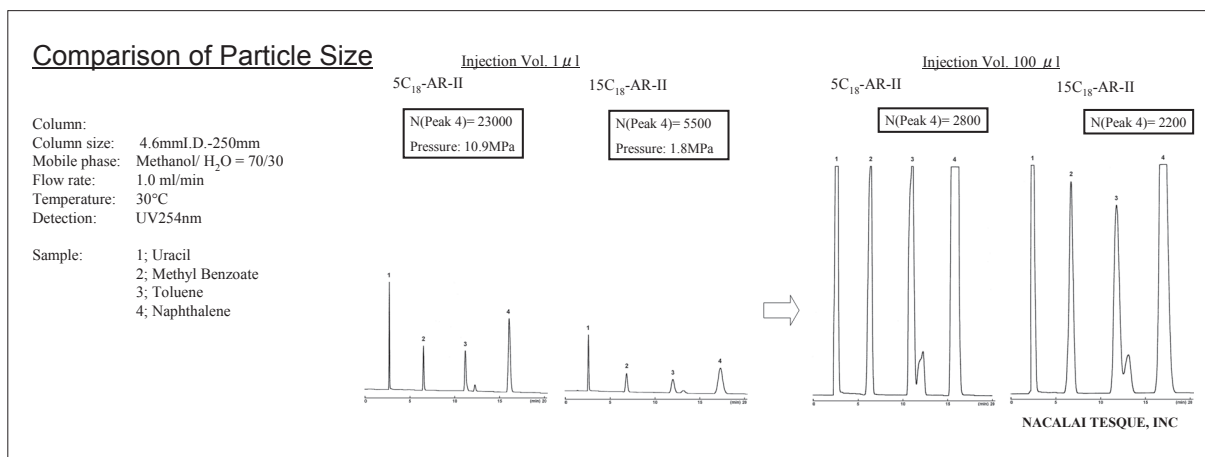

3. Troubleshooting for Increased Pressure

Introduction

Repeated analysis may increase back pressure. Continuous use of HPLC columns under high pressure can cause deterioration and overload of the equipment. Therefore, it is important to monitor column back pressure regularly and solve the problem timely.

Identification of the Clogging Site

The back pressure increase can be due to clogging of a column or clogging of the equipment. First of all, identify the clogging site.

Schematic Diagram of HPLC

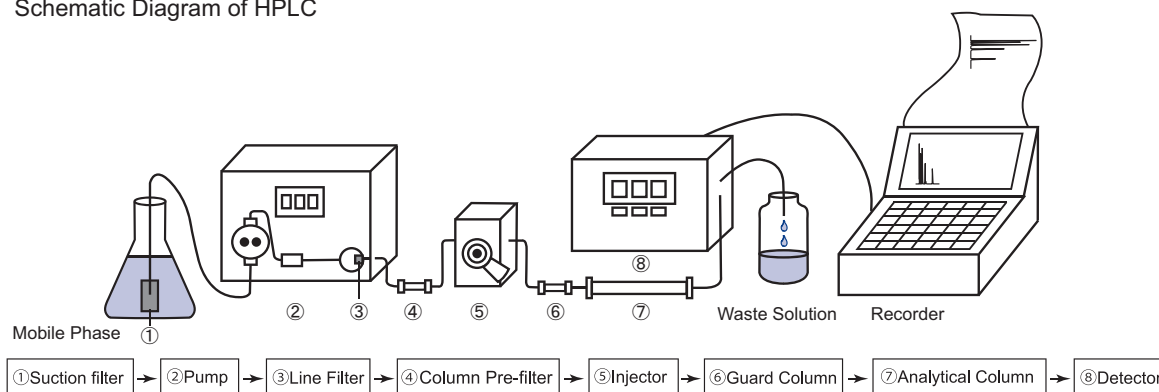

Disconnect the system components one by one to identify the clogged component(s). Start by disconnecting the column from the system and measure the pressure of flowing mobile phase. The pressure should be close to zero. If the flow pressure without a column is normal, then pressure increase is due to the clogged column. The cause of clogging needs to be determined and preventative measures implemented. The column may need to be replaced.

Clogging of Equipment

Identify the specific clogging site according to the method above.

(Case 1) High pressure caused by clogged tubing

- Cause : Salt deposit in tubing.
Solution : Disconnect the column and any other equipment before pumping water through the tubing. Washing in a reversing direction is also an effective way. If the situation does not improve, replace the tubing with a new one.

(Case 2) High pressure caused by clogged pump

- Cause : Line filter of pump is clogged.
Solution : Take apart the line filter, and soak it in the solvent, then clean in an ultrasonic cleaner. If the situation does not improve, replace the line filter with a new one.

(Case 3) High pressure caused by clogged manual injector

- Cause : Manual injector is clogged.
Solution : Inject with 20ml of contaminant dissolving solvent (e.g., methanol) by syringe. Wash both lines in LOAD and INJECT position. Cleaning the injector in an ultrasonic bath is also effective. If solids caused the clogging, wash the injector in a reversing direction. If the situation does not improve, replace the injector with a new one.

What should I do when a clogged column caused pressure increase?

(Case 1) Salt deposit in a column caused by pumping high-organic solvent after using buffer solution

- Cause : Salt deposit in a column.
- Solution : Wash columns for 30 minutes at half the normal flow rate using 10% organic solvent (methanol or acetonitrile) in water to dissolve salt deposit. If the situation does not improve, wash the column with 100% water under the same condition.
- Prevention : To switch to high organic solvent concentration after using a buffer, first wash a column with a salt-free mobile phase (with the same concentration of organic solvent as the buffer), then switch to the mobile phase of higher organic concentration.
Example : To change mobile phase from 10/90 (v/v) acetonitrile/20mmol/l phosphate buffer (pH2.5) to 90/10 (v/v) acetonitrile/water, first wash the column for 15 minutes with 10/90 (v/v) acetonitrile/water, and then switch to 90/10 (v/v) acetonitrile/water.

(Case 2) The sample is not completely dissolved or unfiltered

- Cause : Column frit is clogged by insoluble sample or impurities.
- Solution : Connect the column in the reverse direction and disconnect from the detector, and then wash the column for 30 minutes at half of the usual flow rate with the same mobile phase used for analysis. If the situation does not improve, change the frit in the front end of the column (We can replace end fittings with a paid service fee.).
- Prevention : We strongly recommend filtering sample and/or mobile phase. For more information, please see page 193, Technical Information 4. Sample Pretreatment for HPLC 1) filtration.
- Attention : If the column is continually connecting in the reverse direction, it may deteriorate.

(Case 3) Protein samples that adsorb easily to the column or samples that are slightly soluble in mobile phase

- Cause : Samples have adsorbed to packing material or deposited in a column.
- Solution : Wash the column for 30 minutes with half of the normal flow rate using a solvent that can dissolve the adsorbed substances. Here are washing procedures for each column type.
[Reversed phase columns]
a) When absorbed substances are not proteins, wash with methanol or tetrahydrofuran.
b) When absorbed substances are proteins, wash with 50-70% of acetonitrile/water (containing 0.1% of trifluoroacetic acid). However, proteins may precipitate in high concentration of organic solvent.
[COSMOSIL SL-II] Wash with methanol, tetrahydrofuran or ethanol.
[Fullerene columns] Wash with *o*-dichlorobenzene, 1,2,4-trichlorobenzene.
[COSMOSIL Sugar-D/NH₂/HILIC columns] Wash with 50/50 (v/v) acetonitrile/water for NH₂-MS and 100% water for Sugar-D and HILIC columns.
- Prevention : (a) Choose appropriate pretreatment for each sample. For more information, please see page 193, Technical Information 4.
(b) We also recommend using guard columns, please see page 199, Technical Information 6.
- Attention
- When wash columns, do not connect column outflow end to the detector. Let the solvent flow into waste.
 - Excessive washing may deteriorate the performance of columns.
 - Do not use strongly alkaline solution (more than pH 7.5) or strongly acidic solution (less than pH 1.5) for silica-base packing material.
 - Store columns in manufacturer recommended storage solvent after washing.
 - If the column performance does not improve after washing, replace the column.

(Case 4) Graduated pressure increase over time

- Casue 1 : Contamination of column due to normal long-term use.
Prevention : Wash the column like (Case 3).
- Casue 2 : Column damage due to normal long-term use.
Prevention : Replace the columns.

No improvement in performance after washing.



When the column performance has not improved after washing, we recommend replacing the column to lessen pressure burden on the instrument. You could continue to use the column if peak shape is acceptable and the maximum pressure is less than 20 MPa.

4. Sample Pretreatment for HPLC

Pretreatment before HPLC analysis is often required for samples of low concentration or samples containing analytical contaminants. It improves reproducibility and sensitivity in analysis, and protects HPLC columns. The pretreatment methods are different according to the each sample. The followings are examples of different pretreatments.

1) Filtration

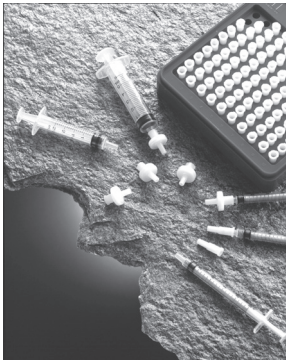
Filtration is a common method used for separating solids from liquids. It extends a column's life by minimizing column damages from solid contaminants such as particles, sediments and colloid substances. It also improves reproducibility of analytical data. We offer both syringe-type and spin-type filters for sample filtration.

	Syringe Filter	Centrifugal Filter
Product	Cosmonice Filter	Cosmospin Filter
Configuration		
Usage	Easy to use Just attach a filter on top of a syringe	Easy to use by centrifugation
Type	W (aqueous system) S (solvent system)	Pore diameter: 0.2 μm Pore diameter: 0.45 μm
Required Equipment	Syringe, Sample Bottle	Centrifuge
Page	Page 80	Page 80

Cosmonice Filter

How to use :

1. Fill a syringe with the sample you want to filter.
2. Attach a Cosmonice filter to the syringe.
3. Push the syringe plunger to filter the sample.
4. Analyze the filtered sample by HPLC.

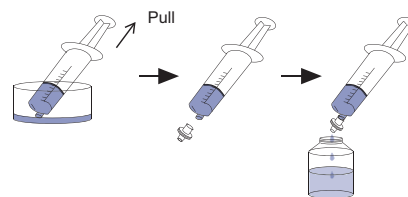

Cosmospin Filter

Components : Sample Reservoir
Sample Collection Tube

How to use :

1. Insert a Cosmospin sample reservoir into a Cosmospin sample collection tube.
2. Add a sample into the Cosmospin sample reservoir.
3. Close the sample collection tube cap and centrifuge.
4. Remove the sample reservoir and collect the filtered sample in the sample collection tube.
5. Analyze the filtered sample by HPLC.

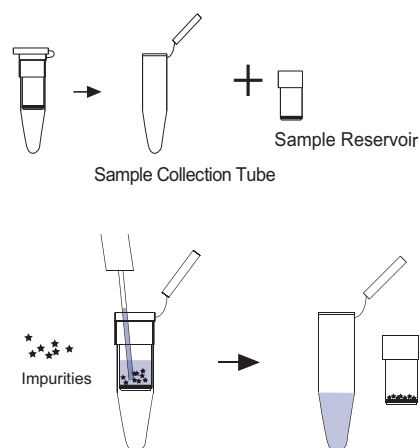

Technical Information

2) Protein Precipitation

Protein precipitation is commonly used to remove proteins in samples for downstream analysis. For example, when analyzing drug concentration in blood samples, proteins have to be removed first. Otherwise, proteins may be adsorbed in columns and interfere with the analysis. Common methods for protein precipitation include salting out, isoelectric point precipitation and precipitation with organic solvents. The following shows a general procedure for protein precipitation with organic solvents.

Procedure for Protein Precipitation :

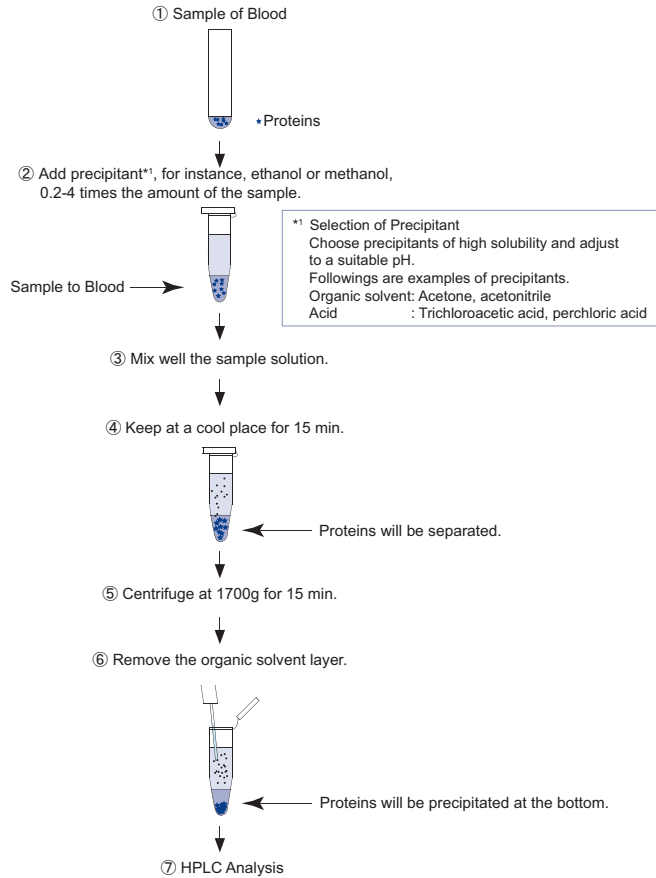

3) Ultrafiltration

Ultrafiltration is a method to concentrate proteins or other macromolecules through a semipermeable membrane with defined pores. Ultrafiltration is applicable for sample desalting, concentrating proteins from dilute solution such as urine samples, or deproteinizing samples with high protein concentration (e.g., blood serum or plasma). Following is a general procedure for ultrafiltration.

Procedure for ultrafiltration :

Procedure for Ultrafiltration :

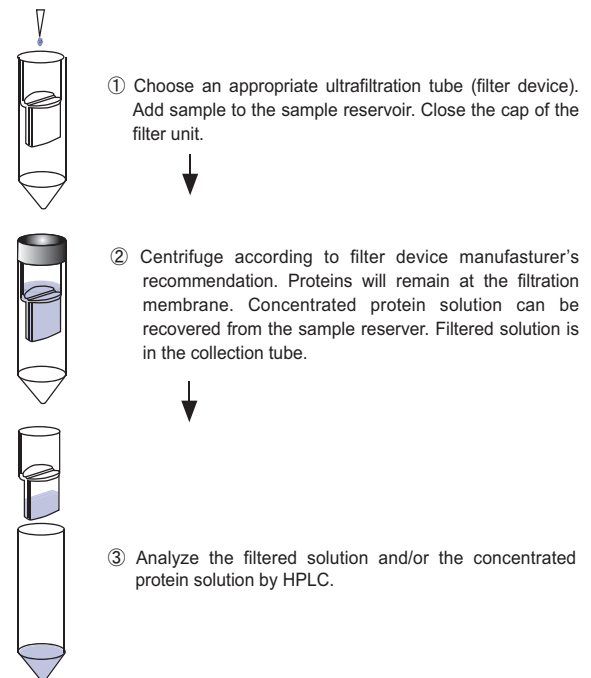

4) Solvent Extraction Method

Solvent extraction is a method to separate compounds due to their unequal solubility in two immiscible liquid phases, usually water and an organic solvent. The method is used to concentrate highly hydrophobic compounds, and consequently increase analytical sensitivity. A buffer solution is added to sample to optimize the pH and target substance is then extracted by an organic solvent such as ether and chloroform. However, when target substance is combined with proteins, solvent extraction may not work well.

Procedure for Solvent Extraction Method :

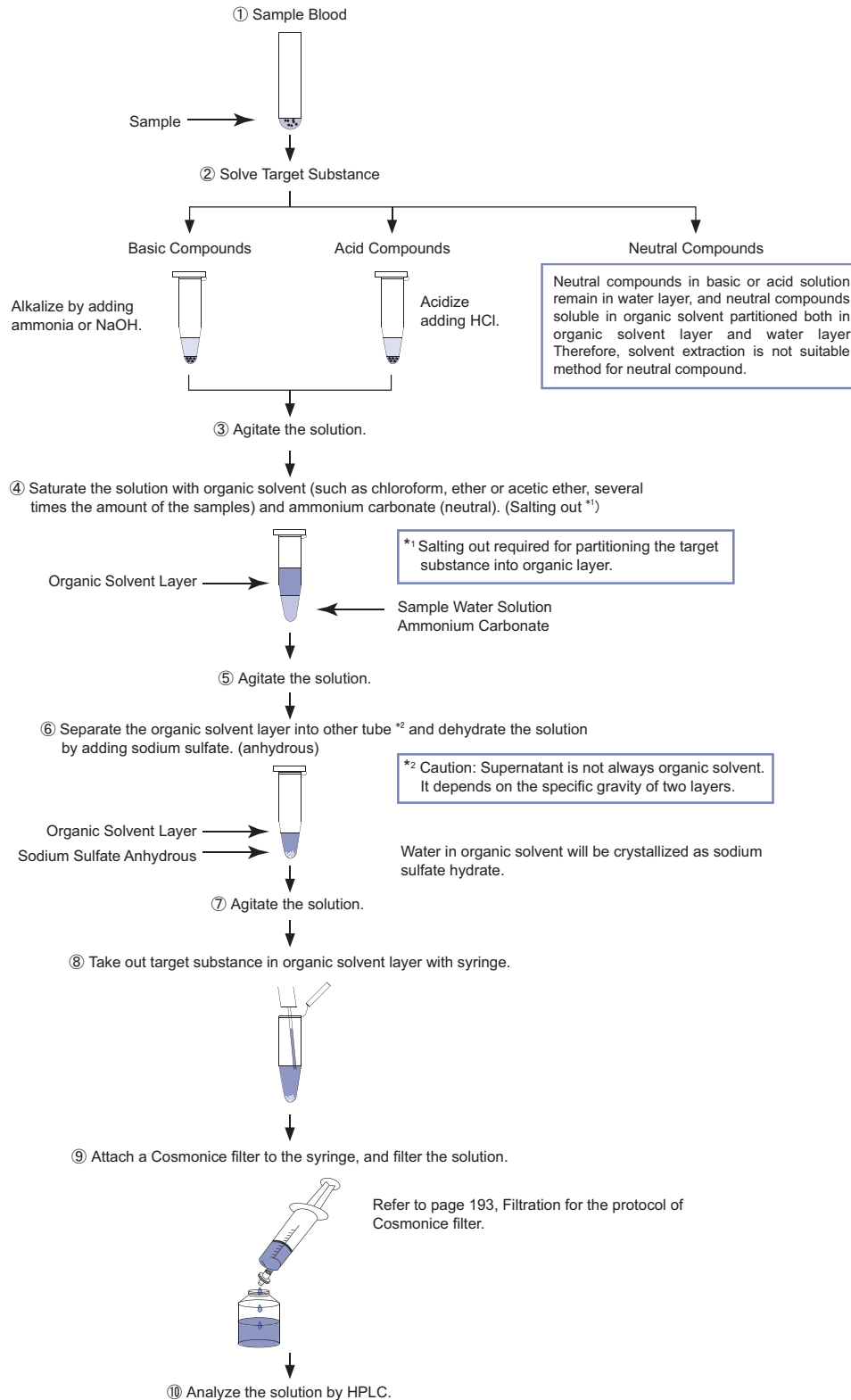

Technical Information

5) Ion Exchange

Pretreatment by ion-exchange resin may be effective for samples that the solvent extraction method cannot be adapted due to its emulsification. A preliminary experiment may be required for the selection of resin and experimental conditions. For example, a negatively charged compound is strongly adsorbed on an anion-exchange resin such as DEAE cellulose resin. Therefore, the target compound is collected by increasing salt concentration of buffer solution or adjusting pH of elution buffer after washing off other weakly adsorbed undesired substances.

Procedure for Ion Exchange :

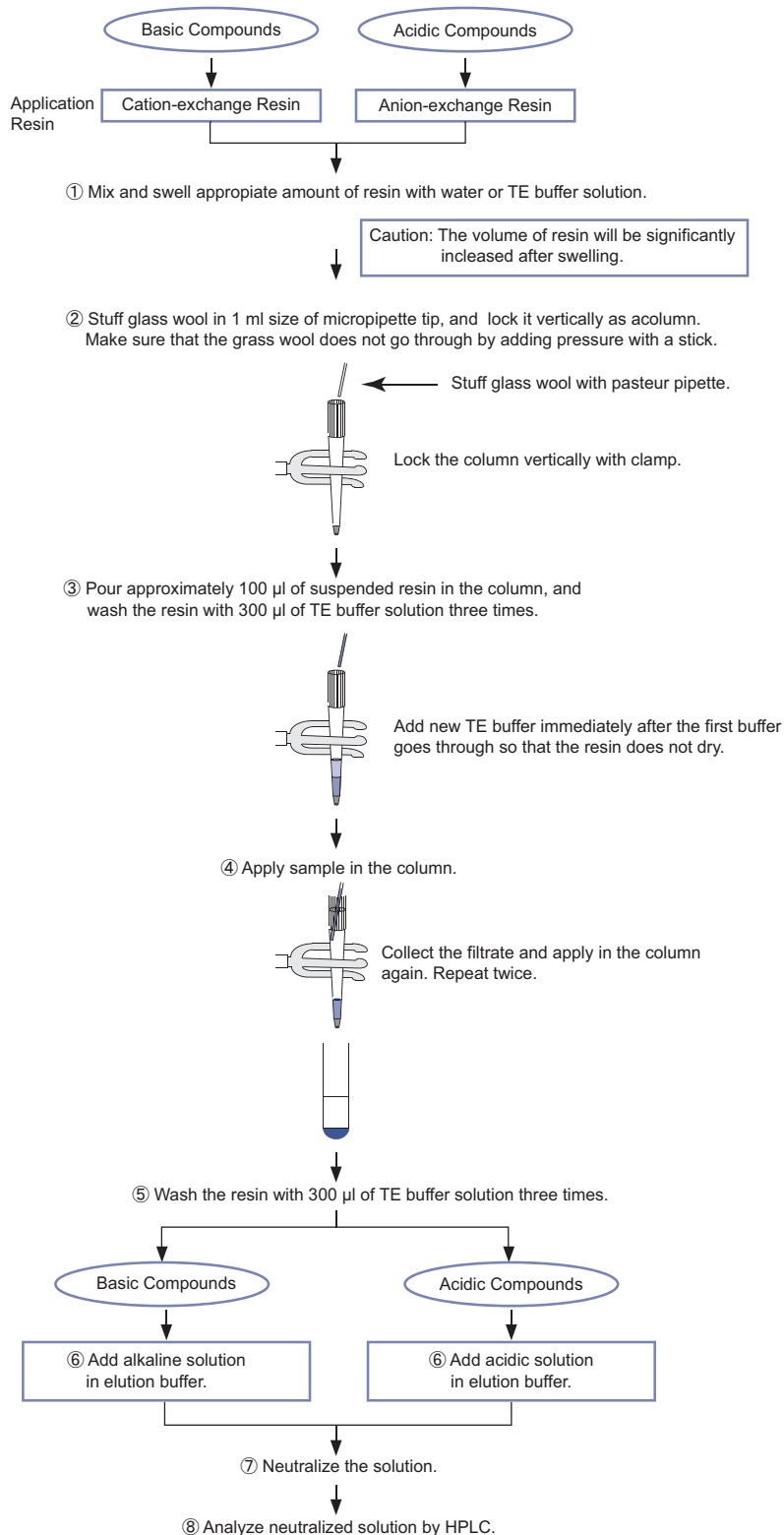

6) Solid Phase Extraction

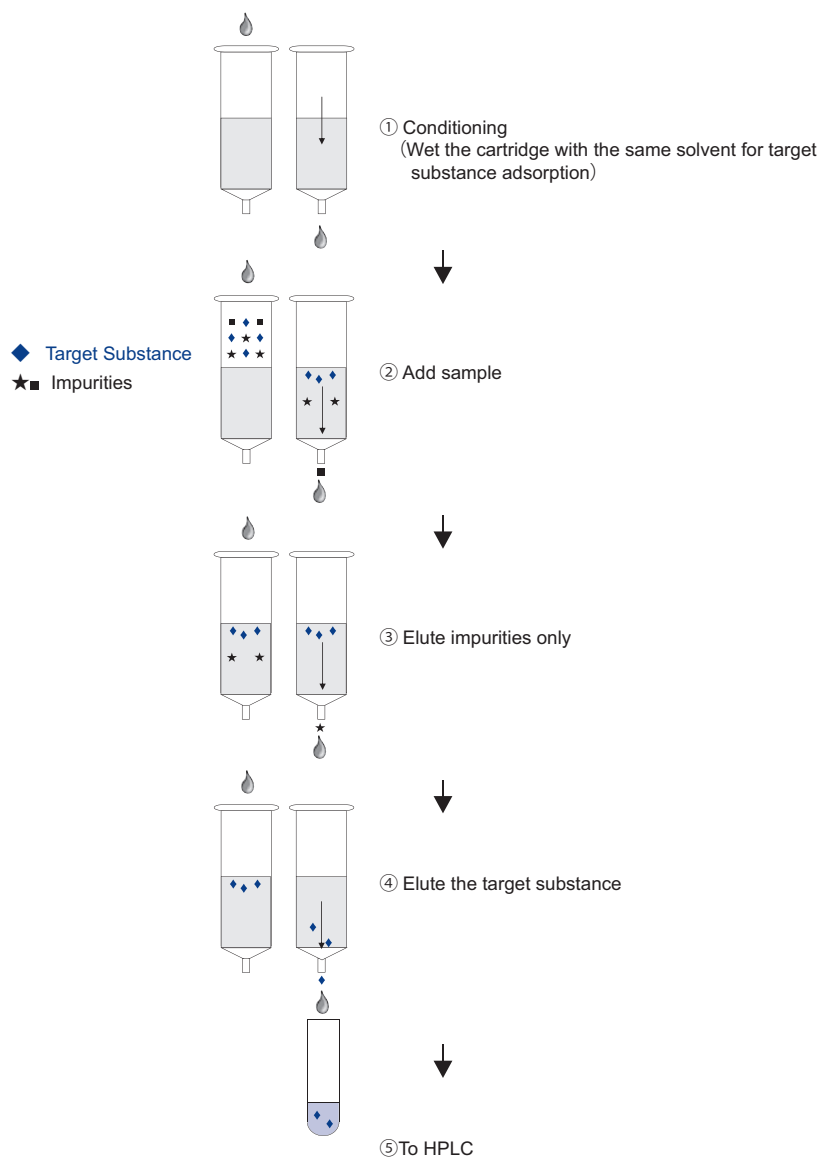

5. Baseline Noise in Gradient Elution

In gradient analysis, incomplete mixing of mobile phases or impurities in water of mobile phase can cause baseline noise. In the former case, it can be improved by using a proper mixer before injector (Baseline 1→2). In the latter case, it can be improved by using a pre-column. Impurities in water are adsorbed on the pre-column (Baseline 2→3). COSMOSIL 5C₁₈-AR-II 4.6 mm I.D. x 10 mm or 10 mm I.D. x 20 mm as a pre-column.

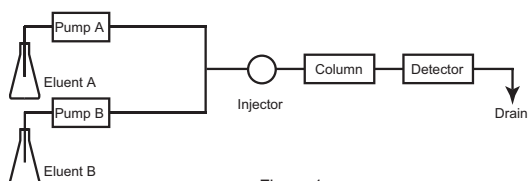
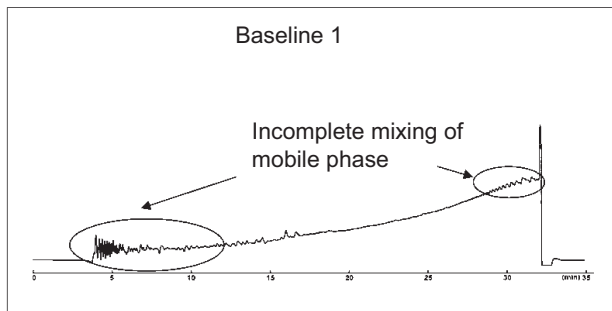

Figure 1



+ Mixer

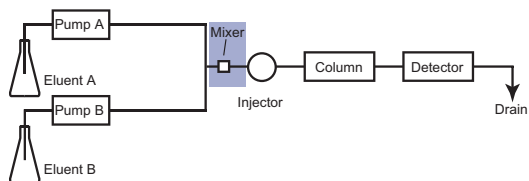
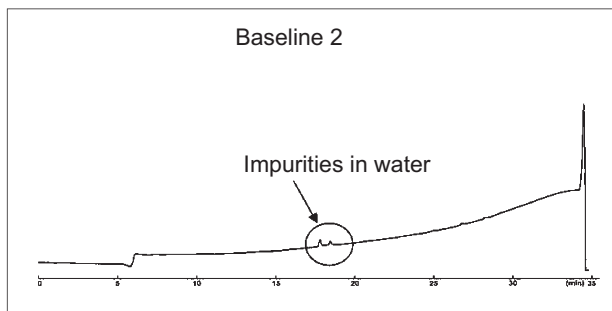

Figure 2



+ Pre-column

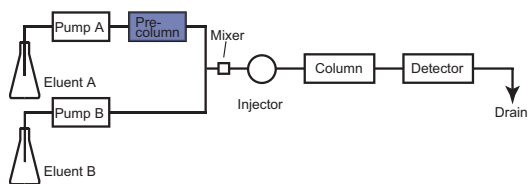
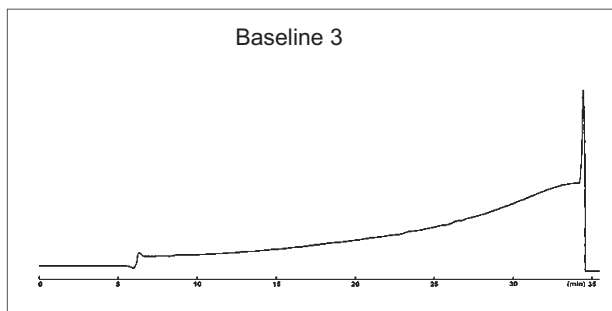

Figure 3



Column COSMOSIL 5C₁₈-AR-300 4.6 mm I.D. x 150 mm
 Precolumn COSMOSIL 5C₁₈-AR-II 4.6 mm I.D. x 10 mm
 Mobile phase A: 0.1% TFA containing water
 B: 0.1% TFA containing 95% acetonitrile
 B: 0% → 100%/30 min liner gradient
 Flow rate 1.0 ml/min
 Temperature 30°C
 Detection UV 220nm

6. Effect of Guard Column

Introduction

The use of guard columns to protect both analytical and preparative columns is highly recommended. COSMOSIL guard columns are packed with the identical packing materials as in analytical and preparative columns. As the result, COSMOSIL guard columns do not affect the performance of the main column.

Selection of Guard Column

Use guard column with the identical packing materials as in the analytical and preparative columns. For guard column size, use the same or smaller inner diameter, and short column length (10–50 mm). For more information on the product code or size, please refer to the respective pages of each column.

(e.g., Main column 5C₁₈-MS-II (20 mm I.D. x 250 mm) → Guard column 5C₁₈-MS-II (10 mm I.D. x 20 mm)

Guard Cartridge

For common size columns (4.6 mm I.D. x 10 mm), guard columns and reasonably priced guard cartridges are both available. Guard cartridges are disposable guard columns with identical packing materials as in analytical columns. When using guard cartridges, a COSMOSIL guard cartridge holder (Product No. 38009-79) is required. The holder is reusable.



COSMOSIL Guard Cartridge Holder (Left)
Guard Cartridge (Right)

Structure of Cartridge

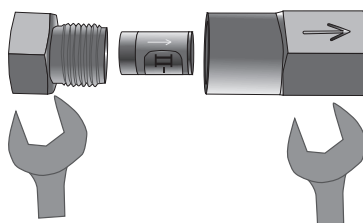

For more information on how to use the guard cartridge, see the attached instruction manual.

Connection to Guard Column

Use COSMOSIL column connecting tube. (Product No. 37843-69) Please refer to page 87 for more information.

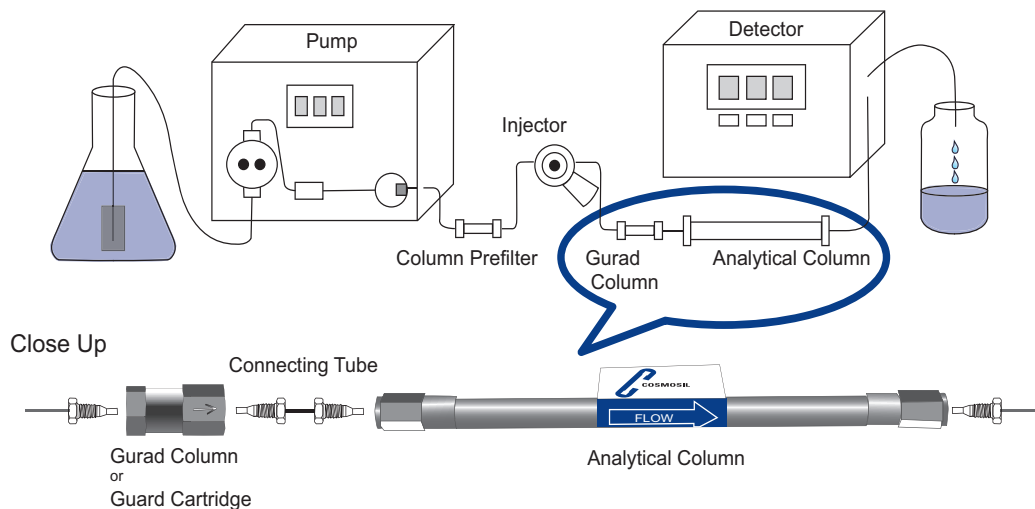

Example of Using Guard Column

The following chromatograms show the use of a COSMOSIL 5C₁₈-MS-II analytical column (4.6 mm I.D. × 150 mm) and the same column connected with its guard column (4.6 mm I.D. × 10 mm). There is no difference in separation characteristics since the packing material is identical in both the guard column and the main column.

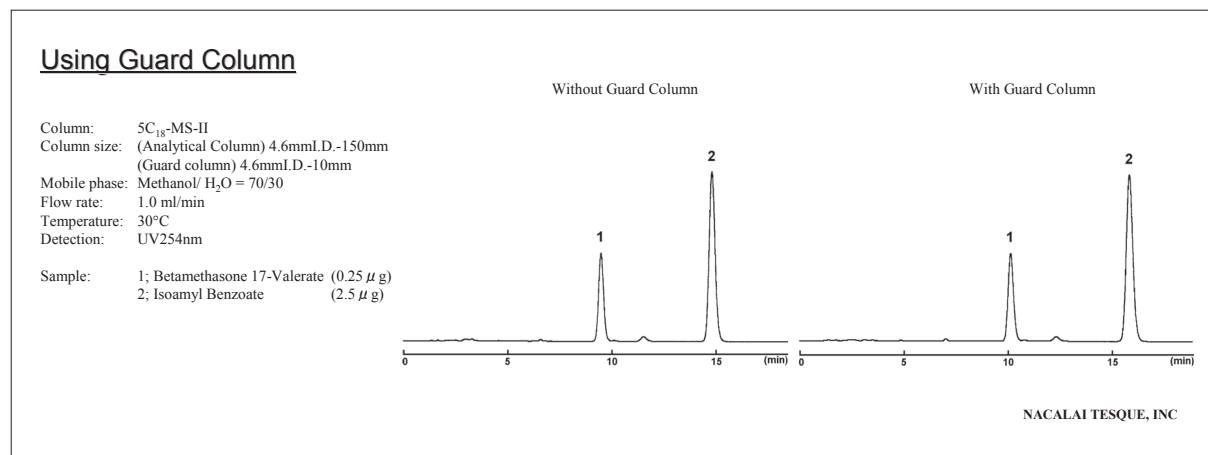

Replacing Guard Column

The following chromatograms show the peak shapes recovered by replacing a deteriorated guard column with a new one. When pressure increases, ghost peak appears, or base line shifts, promptly replace the guard column with a new one. Continued use of a deteriorated guard column can result in premature deterioration of the main column.

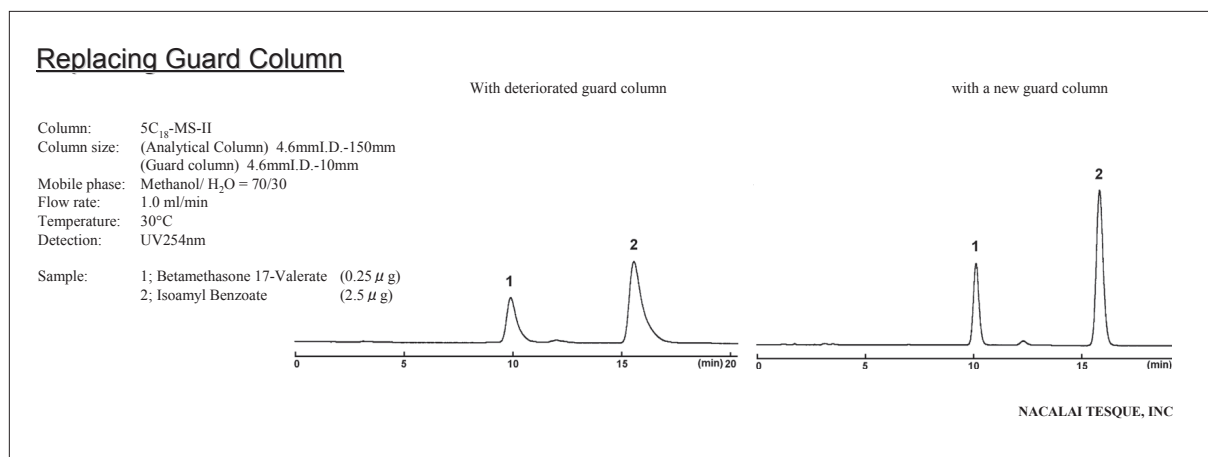



7. Selectivity of Packing Materials in Reversed Phase Liquid Chromatography

Introduction

Reversed phase chromatography is the most commonly used method of HPLC, because of the high theoretical plate number, excellent separation characteristics, reproducibility, and ease of use. Columns packed with octadecyl group bonded type silica gel (C₁₈, ODS) are the most widely used reversed phase chromatography. However, C₁₈ columns provide insufficient separation for compounds similar in hydrophobicity because the main separation mechanism of C₁₈ column is based on hydrophobic interaction. It may improve separation of compounds with similar hydrophobicity by using longer columns, changing mobile phases or changing temperature. However, in many cases, it is probably most effective to use different packing materials which retain compounds base on a secondary interaction in addition to hydrophobic interaction. At Nacalai, we offer a variety of COSMOSIL reversed phase packing materials. Summary of these packing materials and their respective retention mechanism are in Table 1. Retention of compounds in each stationary phase depends on summation of the interactions. Therefore, comprehension of each interaction leads to selection of an appropriate column.

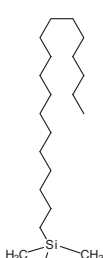
Table 1. Stationary phase and interaction of packing materials

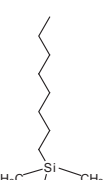
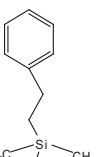
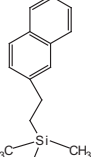
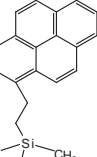
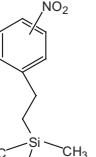
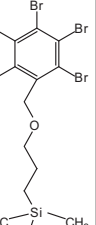
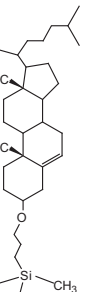
Packing Material	C ₁₈ -MS-II	C ₁₈ -AR-II	C ₈ -MS	PE-MS	πNAP	PYE	NPE	PBB-R	Cholester
Silica Gel	High Purity Porous Spherical Silica								
Average Particle Size	5 μm								
Average Pore Size	approx. 120 Å								
Specific Surface Area	approx. 300 m ² /g								
Bonded Phase									
	Octadecyl Group	Octadecyl Group	Octyl Group	Phenylethyl Group	Naphthylethyl Group	Pyrenylethyl Group	Nitrophenylethyl Group	Pentabromobenzyl Group	Cholesteryl Group
Bonding Type	Monomeric	Polymeric	Monomeric	Monomeric	Monomeric	Monomeric	Monomeric	Monomeric	Monomeric
Main Interaction	Hydrophobic Interaction	Hydrophobic Interaction	Hydrophobic Interaction	Hydrophobic Interaction	Hydrophobic Interaction	Hydrophobic Interaction π-π Interaction Dispersion Force Charge-transfer Interaction	Hydrophobic Interaction π-π Interaction Dipole-dipole Interaction	Hydrophobic Interaction Dispersion Force Interaction	Hydrophobic Interaction Molecular Shape Selectivity
End-capping Treatment	Near-perfect Treatment								
Carbon Load	approx. 16%	approx. 17%	approx. 10%	approx. 10%	approx. 11%	approx. 18%	approx. 9%	approx. 8%	approx. 20%

Technical Information

1) Selectivity for Polar Functional Group

Selectivity

Selectivity for polar functional group is evaluated based on the separation of benzene, nitrobenzene, which has a nitro group, and anisole, which has a methoxy group. The chromatograms below show separation of the three compounds on four COSMOSIL columns: C₁₈-MS-II, PE-MS, πNAP and PYE. Elution order on the C₁₈ column is as following: nitrobenzene, anisole and benzene. Elution orders on the aromatic columns are reversed. Separation on the C₁₈ column is based on hydrophobic interaction only. On the other hand, the packing materials on the other three columns have aromatic rings and reverse the elution order by π-π interaction.

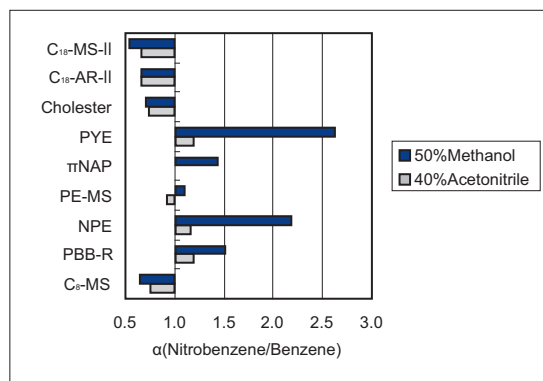

The graph of selectivity for polar functional group is shown below. Among nine COSMOSIL columns, PYE and NPE columns have the highest selectivity factors for polar groups. As to mobile phases, methanol is more effective than acetonitrile for separation using π-π interaction.

Selectivity for Polar Functional Group

Column: 5C₁₈-MS-II, SPE-MS, πNAP, SPYE
 Column size: 4.6mm I.D.-150mm
 Mobile phase: Methanol / H₂O = 50/50
 Flow rate: 1.0 ml/min
 Temperature: 30°C
 Detection: UV254nm

Sample: 1; Nitrobenzene (0.13 μg)
 2; Anisole (1.5 μg)
 3; Benzene (4.0 μg)

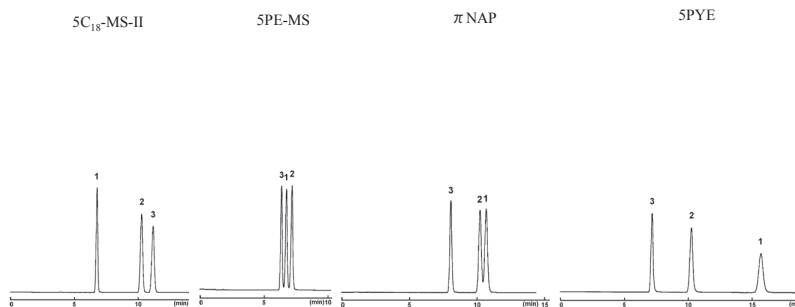
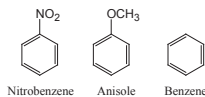

NACALAI TESQUE, INC

Application

• Separation of Tolunitrile Position Isomers

Tolunitriles have three position isomers. It is difficult to separate ortho and para isomers by C₁₈ or PE-MS column because of lack of poor π-π interaction. On the other hand, the isomers are well separated on PYE or NPE column which has strong π-π interaction.

COSMOSIL Application Data

Column: 5C₁₈-MS-II, SPE-MS, SNPE, SPYE
 Column size: 4.6mm I.D.-150mm
 Mobile phase: Methanol/ H₂O = 40/60
 Methanol/ H₂O = 60/40
 Flow rate: 1.0 ml/min
 Temperature: 30°C
 Detection: UV254nm

Sample: o-Tolunitrile (2.0 μg)
 m-Tolunitrile (2.0 μg)
 p-Tolunitrile (1.0 μg)

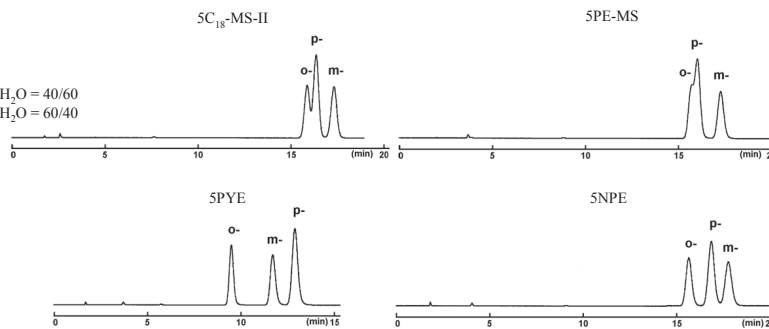
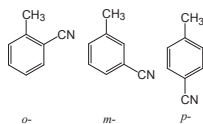

NACALAI TESQUE, INC

2) Selectivity for Dipole

Selectivity

Selectivity for dipole is evaluated based on the separation of 1,5-dinitronaphthalene and 1,8-dinitronaphthalene. Dinitronaphthalenes (peak 1 and 2) were strongly retained on PYE and NPE because of π - π interaction compared with dimethylnaphthalenes. However, there is a slight difference between these two columns. While 1,5-dinitronaphthalene (peak 2) was preferentially retained on PYE, 1,8-dinitronaphthalene (peak 1) was retained longer on NPE. The results with NPE indicate the presence of strong dipole-dipole interaction. The two nitro group dipoles in 1,8-dinitronaphthalene are aligned for a much greater dipolar coupling with the bonded nitrophenyl group in NPE than 1,5-dinitronaphthalene.

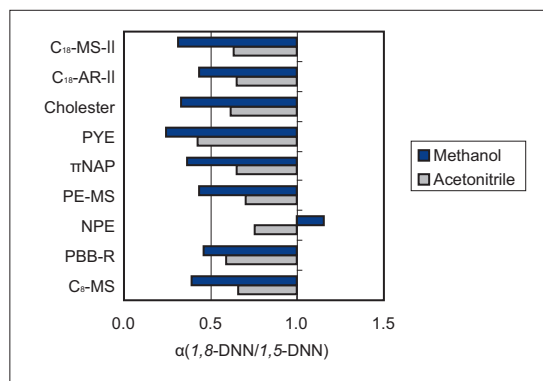

Selectivity for Dipole

Column size: 4.6mm I.D.-150mm
 Mobile phase: C₁₈-MS-II Methanol / H₂O = 80/20
 NPE Methanol / H₂O = 70/30
 PYE Methanol / H₂O = 90/10
 Flow rate: 1.0 ml/min
 Temperature: 30°C
 Detection: UV254nm
 Sample:
 1; 1,8-Dinitronaphthalene(1,8-DNN) (0.21 μ g)
 2; 1,5-Dinitronaphthalene(1,5-DNN) (0.11 μ g)
 3; Naphthalene (0.25 μ g)
 4; 1-Methylnaphthalene (0.35 μ g)
 5; 1,5-Dimethylnaphthalene (0.42 μ g)

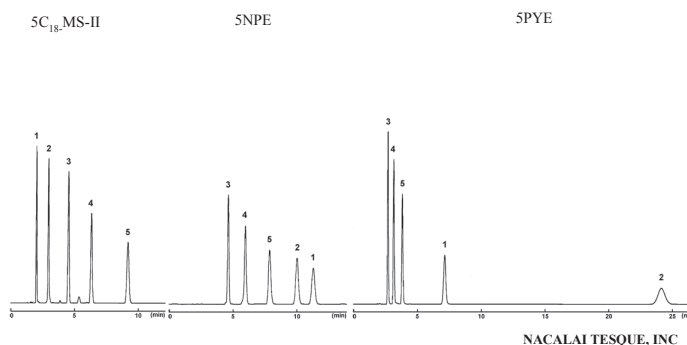
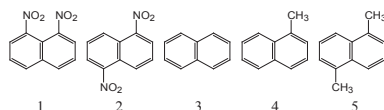

Application

• Separation of Phthalonitrile Position Isomers

Phthalonitriles have three position isomers. NPE or PYE completely separates these compounds due to π - π interaction. Furthermore, NPE strongly retains o-phthalonitrile due to dipole-dipole interaction.

COSMOSIL Application Data

Column:
 Column size: 4.6mm I.D.-150mm
 Mobile phase: 5C₁₈-MS-II Methanol / H₂O = 30/70
 5NPE Methanol / H₂O = 40/60
 5PYE Methanol / H₂O = 80/20
 Flow rate: 1.0 ml/min
 Temperature: 30°C
 Detection: UV254nm
 Sample:
 o-; Phthalonitrile (0.3 μ g)
 m-; Isophthalonitrile (3.0 μ g)
 p-; Terephthalonitrile (0.15 μ g)

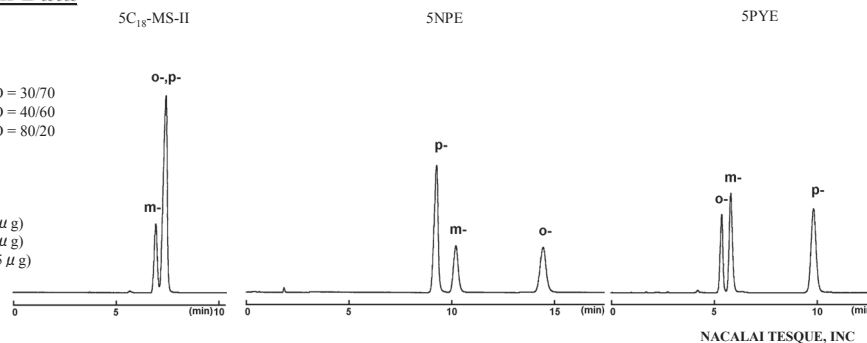
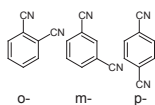

Technical Information

3) Selectivity for Polyaromatic Compounds

Selectivity

Selectivity for polyaromatic compounds is evaluated based on the separation of benzene, naphthalene and anthracene. The elution orders in all columns are the same : benzene, naphthalene and anthracene. Retention increases in all columns with increasing number of aromatic rings. In addition, highly dispersive packing materials such as PBB and PYE show much stronger retention for polyaromatic compounds due to dispersion interaction.

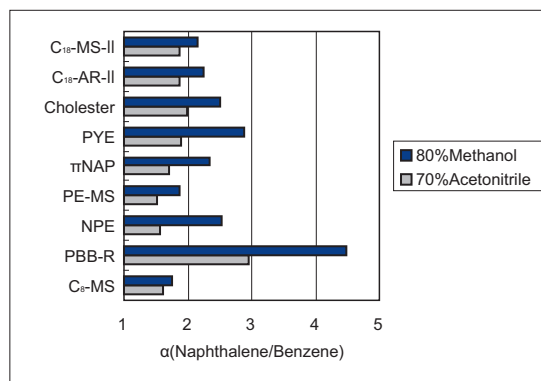

Selectivity for Polyaromatic Compounds

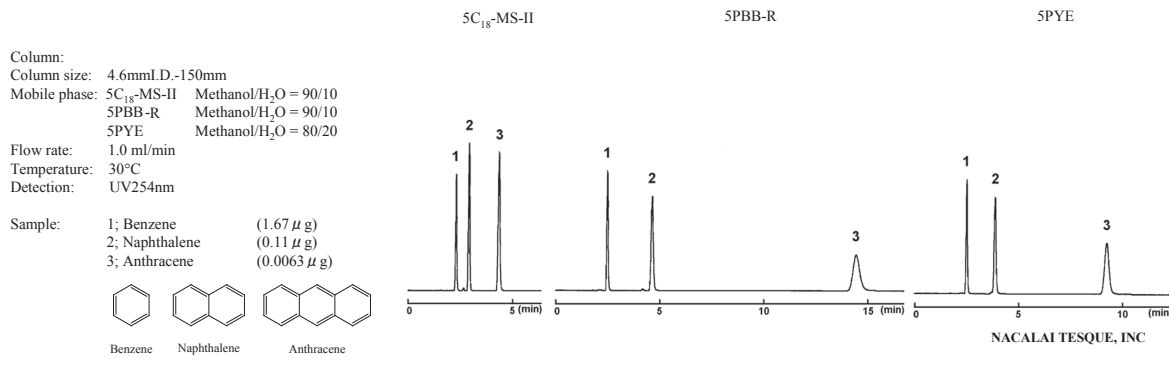

Application

• Separation of Dibenzosuberone and Dibenzosuberone

C₁₈ retains dibenzosuberone (peak 1) longer than dibenzosuberone (peak 2). On the other hand, PBB-R and PYE retain dibenzosuberone (peak 2), which has a π-electron conjugated system, longer than dibenzosuberone (peak 1).

COSMOSIL Application Data

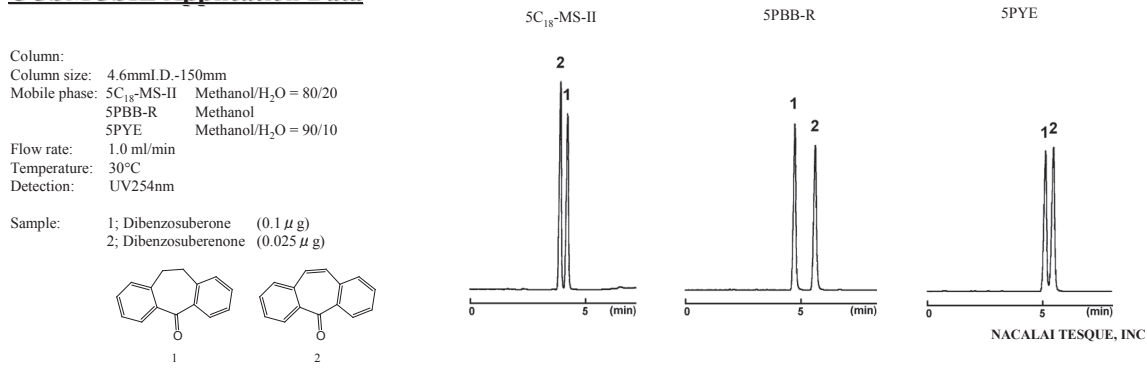

4) Selectivity for Molecular Shape

Selectivity

Selectivity for Molecular Shape is evaluated based on the separation of chrysene and benz[a]anthracene. The isomers of two polyaromatic hydrocarbons, which consist of four benzene rings, are difficult to separate because of the similar hydrophobicity or aromaticity. However, PYE and Cholester columns, which recognize molecular shape, enable them to separate chrysene and benz[a]anthracene.

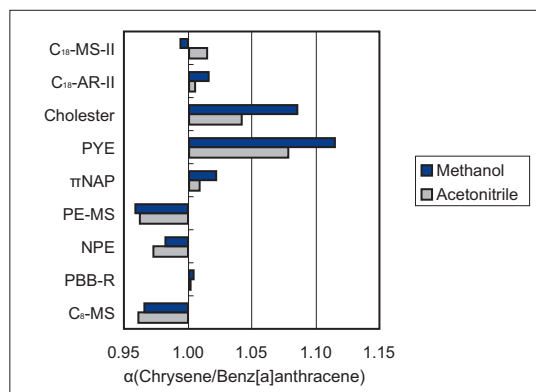

Selectivity for Molecular Shape

Column: 4.6mm I.D.-150mm
 Column size: 5C₁₈-MS-II, 5PYE, Cholester, 5PE-MS
 Mobile phase: 5C₁₈-MS-II, 5PYE: Methanol / H₂O = 90/10
 Cholester: Methanol
 5PE-MS: Methanol / H₂O = 80/20
 Flow rate: 1.0 ml/min
 Temperature: 30°C
 Detection: UV254nm

Sample: 1; Tetraphene [Benz[a]anthracene] (0.04 μg)
 2; Chrysene (0.04 μg)

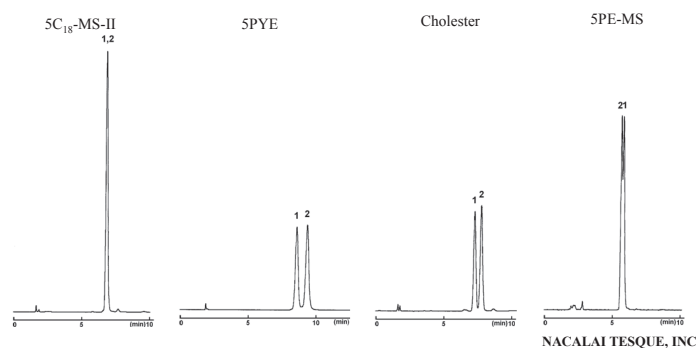
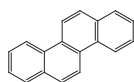
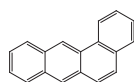

Application

• Separation of Diastereomers (*threo*- and *erythro*-)

C₁₈ cannot separate the *threo* and *erythro* forms. On the other hand, PYE retains the planar *erythro* form longer than the *threo* form.

COSMOSIL Application Data

Column: 4.6mm I.D.-150mm
 Column size: 5C₁₈-MS-II, 5PYE
 Mobile phase: Methanol / H₂O = 80/20
 Flow rate: 1.0 ml/min
 Temperature: 30°C
 Detection: UV254nm

Sample: 1; *Threo* form
 2; *Erythro* form

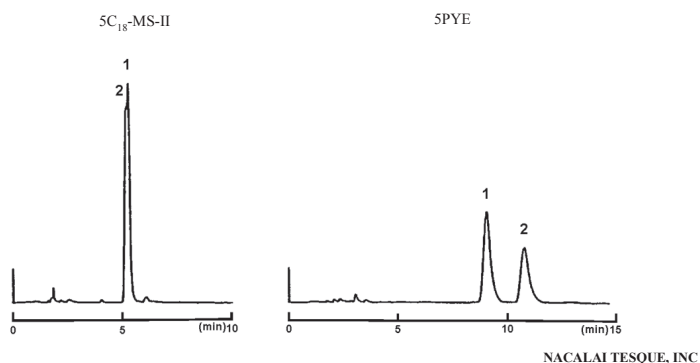
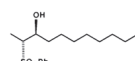
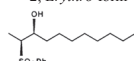

Technical Information

5) Selectivity for Halides

Selectivity

Selectivity for halides is evaluated based on the separation of chlorobenzene and bromobenzene. PBB-R shows the highest selectivity factor due to dispersion interaction of the five bromine atoms.

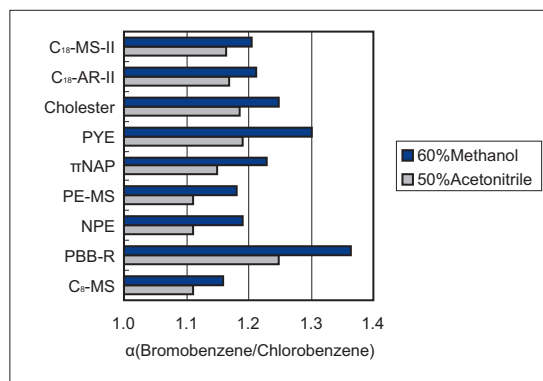

Application

Selectivity for Halide

Column: 4.6mm I.D.-150mm
 Mobile phase: Methanol/ H₂O = 60/40
 Flow rate: 1.0 ml/min
 Temperature: 30°C
 Detection: UV254nm

Sample: 1; Toluene (3.3 μg)
 2; Chlorobenzene (3.3 μg)
 3; Bromobenzene (3.3 μg)

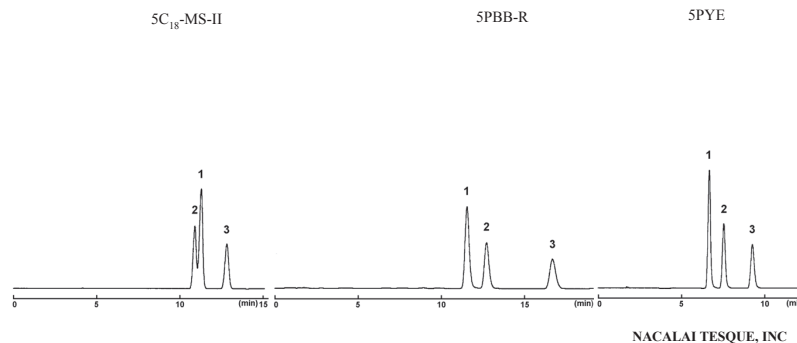
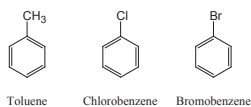

● Separation of Halogen Exchange Reaction Products

PYE and PBB-R retain dispersed iodine atom longer than bromine atom. As a result, PYE and PBB-R can separate the complicated bromine and iodine compounds that C₁₈ cannot separate.

COSMOSIL Application Data

Column: 4.6mm I.D.-150mm
 Mobile phase: 5C₁₈-MS-II Methanol/ H₂O = 90/10
 PBB-R Methanol
 Flow rate: 1.0 ml/min
 Temperature: 30°C
 Detection: UV254nm

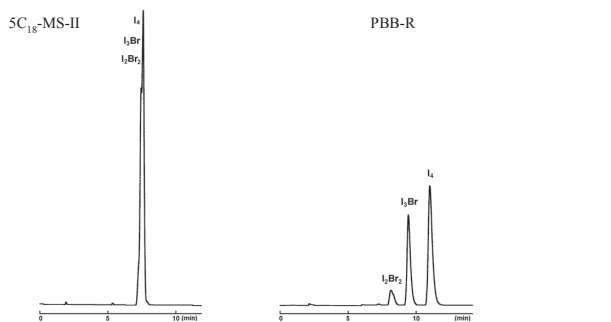
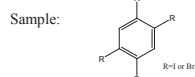

Sample courtesy of Dr.H.Yamamoto,RIKEN

AP-1029

6) Selectivity for Hydrophobicity

Selectivity

Selectivity for hydrophobicity is evaluated based on the separation of alkylbenzenes. Two C₁₈ and Cholester show similar high selectivity for hydrophobicity. Other columns show less hydrophobic selectivity than C₁₈.

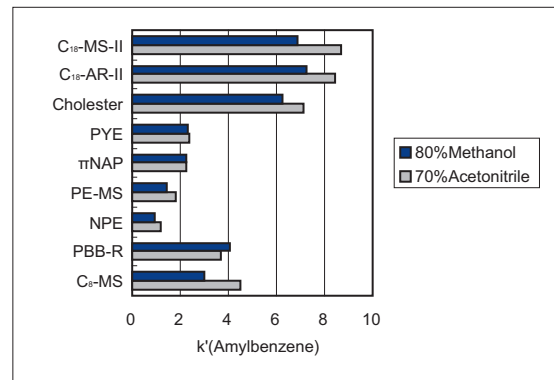

Selectivity for Hydrophobicity

Column: 5C₁₈-MS-II
 Column size: 4.6mm I.D. - 150mm
 Mobile phase: Methanol/H₂O = 80/20
 Flow rate: 1.0 ml/min
 Temperature: 30°C
 Detection: UV254nm

Sample: 1; Benzene (1.67 μg)
 2; Toluene (1.67 μg)
 3; Ethylbenzene (1.67 μg)
 4; Propylbenzene (1.67 μg)
 5; Butylbenzene (1.67 μg)
 6; Amylbenzene (1.67 μg)

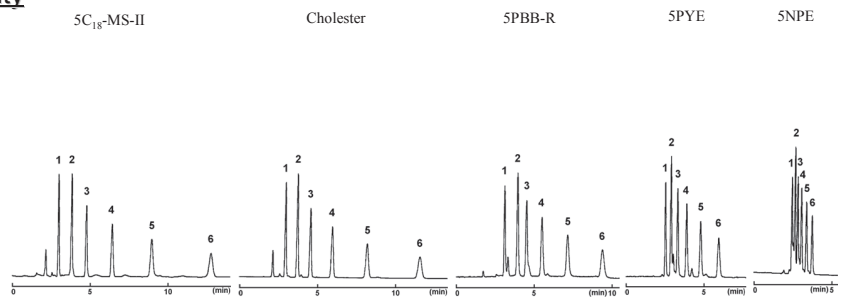
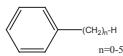

NACALAI TESQUE, INC

Lower concentration of organic solvent in mobile phase leads to much retention in reversed phase chromatography. In case of NPE, when methanol concentration is reduced to 60%, the retention times increase to those similar to C₁₈ with 80% methanol.

Adjustment of Retention

Column: 5NPE
 Column size: 4.6mm I.D. - 150mm
 Mobile phase: Methanol/H₂O = 80/20
 Flow rate: 1.0 ml/min
 Temperature: 30°C
 Detection: UV254nm

Sample: 1; Benzene (1.67 μg)
 2; Toluene (1.67 μg)
 3; Ethylbenzene (1.67 μg)
 4; Propylbenzene (1.67 μg)
 5; Butylbenzene (1.67 μg)
 6; Amylbenzene (1.67 μg)

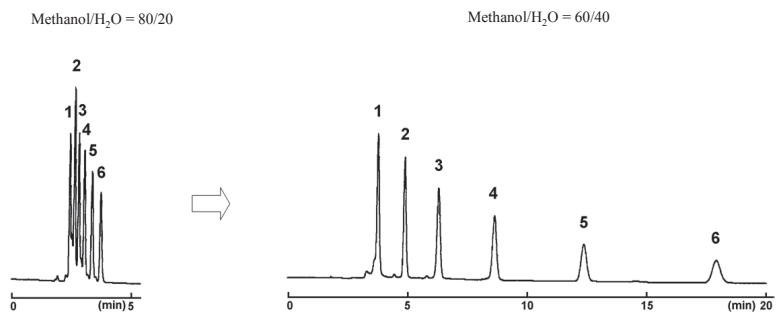
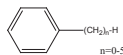

NACALAI TESQUE, INC

8. Methods in Developing Mobile Phase Condition for C₁₈ Column

Introduction

In reversed phase HPLC, octadecyl group bonded silica columns (C₁₈, ODS) are the most widely employed. A proper mobile phase condition for C₁₈ columns can be achieved by referring to publications, application notes from manufactures and your own experiences. This section shows traditional methods of developing mobile phase condition. The following columns are used as examples because of their popularity.

Packing material : COSMOSIL 5C₁₈-MS-II, COSMOSIL 5C₁₈-AR-II
 Column size (I.D. x length) : 4.6 mm I.D x 150 mm

Methods for Developing Mobile Phase Conditions

In the Isocratic method, the mobile phase composition remains constant throughout the run. In the gradient method, the mobile phase composition changes. Each method needs strict preparation of the mobile phase and control of the column temperature to achieve good separation.

• Isocratic Method

Methods for developing mobile phase condition generally proceed as follows. First, elute the samples with strong solvents to check whether the samples can be detected. Then, separate the samples by controlling the retention time through changing the mobile phase condition. Increasing the concentration of strong elution efficiency solvents results in shorter retention time and decreasing in concentration of them results in longer retention time. If your samples are ionizable, such as acid and amine group, pH control with buffers is highly advisable. The ionization control method or ion-pair chromatography is used to increase the retention of ionized samples. The method uses ion-pair reagents (e.g., alkyl benzene sulfonate for basic compounds, quaternary ammonium for acidic compounds) into in the mobile phase to form ion pairs with samples.

(e.g.,) Procedures for Basic Condition Setting

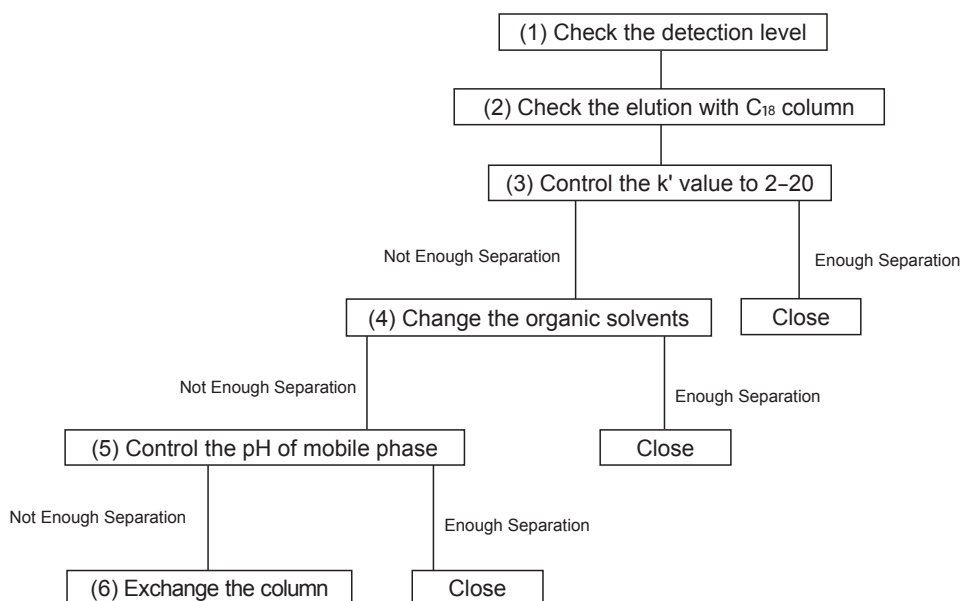

I. HPLC Columns

II. UHPLC Columns

III. Preparative Packing Materials

IV. Related Products

V. Applications

VI. Technical Notes

VII. Index

1. Check the detection of samples with strong elution solvents. In this step, check the detection by connecting the injector directly to the detector without a column.
2. Consult references and carbon numbers and check the elution with C₁₈ column using aqueous mobile phase with methanol.
3. Control the k' value to 2–20 by changing the amount of the methanol in the mobile phase.
4. If the separation is not enough, change the methanol to acetonitrile or add tetrahydrofuran to change the selectivity.
5. If tailing peaks occur for basic compounds, control the pH by adding buffers to the mobile phase.
6. If separation is not satisfactory after step 5, change the column to other C₁₈ columns or columns with different stationary phases such as alkyl-based, aromatic-based and others.

- **Gradient Method**

Gradient method changes organic solvent composition continuously in the mobile phase. It is useful for shortening the separation time of samples with wide range of hydrophobicity and molecular weight, with long elution time, and with great changes in retention time by slight changes in organic solvent composition. It is also useful for large molecule weight compounds like peptides. Gradient method is not compatible with RI detector. Gradient method development is beyond the scope that can be discussed here.

Easy Method to Set the Reversed Phase Condition

Reversed phase chromatography does not have an easy method to set mobile phase conditions, unlike normal phase chromatography mobile phase conditions that can simply be determined by thin layer chromatography. Therefore, the composition of the mobile phase (concentration of organic solvent) is often determined by repeated trial and error. If you know the structure of the analytes, here is a general instruction on configuring an appropriate mobile phase organic solvent concentration.

Suitable concentration of organic solvent for basic chemical skeleton + effects from substituents
= The best organic solvent concentration

● Condition Setting

Select the condition based on retention time of the basic chemical skeleton shown in Figure 1, then adjust for the effect of hetero atom and substituents.

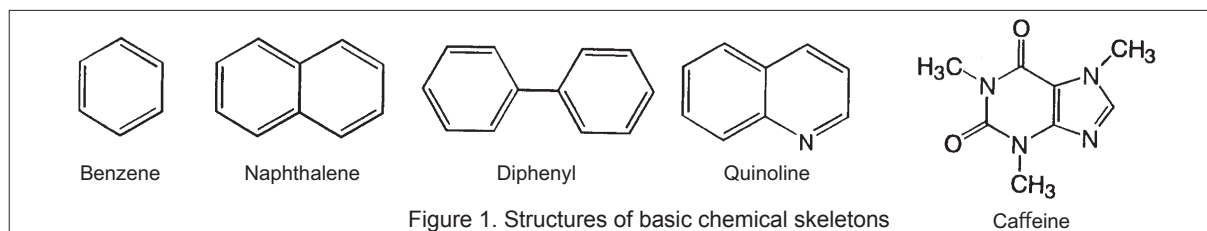

1. Select the best concentration of organic solvent with its corresponding basic chemical skeleton. *Refer Table 1

2. Adjust the concentration of the organic solvent considering effect of hetero atom. *Refer Table 2

3. Adjust the concentration of organic solvent considering the effects from substituents. *Refer Table 3

Contain dissociate substituent

No dissociate substituent

4. Adjust the concentration of the organic solvent considering effects from dissociable substituent.

Complete

Complete

1. Choose a compound of similar basic chemical structure as the target sample in Figure 1. Select the best organic solvent concentration.

Table 1. Retention time of the basic chemical skeleton

Basic skeleton	Column	Retention Time Under Different Methanol Concentrations (min)						
		80%	70%	60%	50%	40%	30%	20%
Benzene	5C ₁₈ -MS-II	-	4	7	11	20	-	-
	5C ₁₈ -AR-II	-	4	7	13	23	-	-
Naphthalene	5C ₁₈ -MS-II	5	8	18	-	-	-	-
	5C ₁₈ -AR-II	5	10	22	-	-	-	-
Diphenyl	5C ₁₈ -MS-II	8	13	-	-	-	-	-
	5C ₁₈ -AR-II	7	15	-	-	-	-	-
Quinoline	5C ₁₈ -MS-II	-	-	-	-	6	11	-
	5C ₁₈ -AR-II	-	-	-	-	8	17	-
Caffeine	5C ₁₈ -MS-II	-	-	-	-	-	4	9
	5C ₁₈ -AR-II	-	-	-	-	-	4	9

Column: COSMOSIL 4.6 mm I.D. × 150 mm Flow Rate: 1.0 ml/min Detection: UV 254 nm

2. Adjust the organic solvent concentration considering effect of hetero atom as shown in Table 2.

Table 2. Organic solvent concentration adjustment from hetero rings or polycyclic aromatics

Hetero Rings, polycyclic Aromatics		Sample	5C ₁₈ -MS-II	5C ₁₈ -AR-II
1 of Conjugate Ring		Benzene	+10%	+10%
Heterocyclic Hetero Atom	1 of S	Thiophene	±0%	±0%
	1 of O	Furane	-5%	-5%
	1 of N	Pyridine	-20%	-10%
1 of Carbonyl Group		Quinone	-5%	-5%
1 of Double Bond		-	-5%	-5%

3. Adjust the concentration of organic solvent considering effect from substituents as shown in Table 3.

Table 3. Organic solvent concentration adjustment from substituents

Substituent	Methanol Concentration		Substituent	Methanol Concentration
	5C ₁₈ -MS-II	5C ₁₈ -AR-II		
-F	0	0	-CH ₂ - (Alkyl-chain) MeOH concentration of basic skeleton	100-90% +10% (4 of -CH ₂ -) 90-80% +10% (3 of -CH ₂ -) 80-60% +10% (2 of -CH ₂ -) < 60% +10% (1 of -CH ₂ -)
-Cl	+10%	+10%		
-Br	+10%	+10%		
-I	+20%	+15%		
-CONH ₂	-40%	-40%		
-COCH ₃	-10%	-10%		
-COOCH ₃	0	0	-Phenyl MeOH concentration of basic skeleton	100-90% +5% (1 of - Phenyl) 90-60% +10% (1 of - Phenyl) < 60% +20% (1 of - Phenyl)
-OCH ₃	0	0		
-CHCH ₂ O	-10%	-10%		
-CH ₂ OH	-30%	-30%		
-OH	-30%	-30%		
-NO ₂	-10%	-5%		
-CN	-20%	-15%		
-NH ₂	-40%	-30%		
-SCH ₃	+10%	+10%		

Column: COSMOSIL 4.6 mm I.D. × 150 mm

Flow Rate: 1.0 ml / min Detection: UV 254 nm

* Effect may shift somewhat by the position of the substituent.

4. Compounds with a dissociative substituent are extremely sensitive toward slight pH change. Maintain consistent mobile phase pH to obtain reproducible data. Table 4 shows the influence of acidic (pH 2) and neutral (pH 7) substituents to the retention.

Table 4. Effect of dissociate substituent to organic solvent

Dissociable Substituent	Change of Methanol Concentration (pH 2)	Change of Methanol Concentration (pH 7)
-COOH	-10~-20%	-30~-40%
-SO ₃ H	-20~-40%	-30~-40%
-PO ₄ H ₂	-20%	-50%
-BO ₂ H ₂	-20%	-20%
-NH ₂ (molecular type)	-60%	-10%
-NH ₂ (cyclic amine)	-50~-60%	-10~-20%
-NH ₂ (ionic type)	-	-40~-50%

Column :COSMOSIL 5C₁₈-MS-II, 4.6 mm I.D. x 150 mm
Buffer pH2 :20mmol/l H₃PO₄
pH7 :20mmol/l H₃PO₄/Na₂HPO₄=2/3
Flow Rate :1.0 ml/min
Detection :UV 254 nm

Technical Information

● Example of Condition Setting

Column: COSMOSIL 5C₁₈-MS-II 4.6 mm I.D. × 150 mm

(1) 5-Benzyloxyindole

<Calculation> Basic skeleton Naphthalene like + (hetero ring N)
 =70%+ (-20%)
 =50%

Substituent (Phenyl) + (-OCH₂- is equal to -OCH₃)
 =(+10%) + (+0%)

Basic skeleton + Substituent = 50% + (+10%) = 60%

<Result> 60%Methanol (Methanol:Water=60:40)
 Retention time=13.7 min

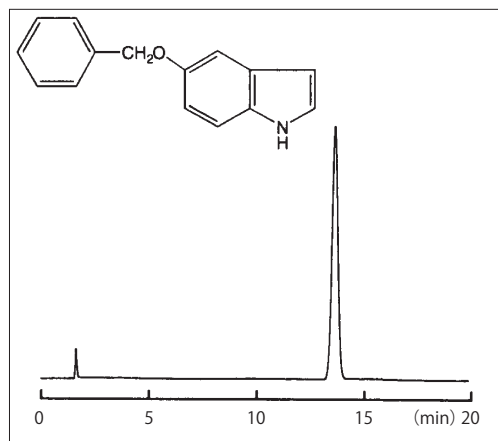

Figure 2. Analysis of 5-Benzyloxyindole

(2) Homovanillic Acid

<Calculation> Basic skeleton Benzene=60%

Nondissociative substituent (-OH) + (-OCH₃) + (-CH₂)
 =(-30%) + (0%) + (+10%)
 = -20%

Dissociable substituent -COOH = -10~-20% (pH 2)
 -30~-40% (pH 7)

Basic skeleton + Substituent = Methanol concentration is
 Acid range (pH 2) 30-20%
 Neutral range (pH 7) 10-0%

<Result> (pH2) 30%Methanol : Retention time=5.7 min
 20%Methanol : Retention time=11.7 min

(pH7) 10%Methanol : Retention time=4.0 min
 0%Methanol : Retention time=12.1 min

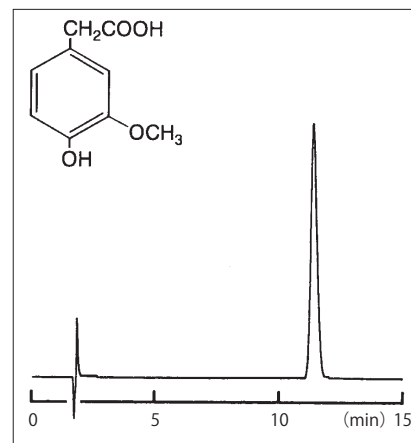

Figure3. Analysis of 20% Methanol (pH 2)

* Actual retention prediction results may have ±10% error in organic solvent concentration calculated.

9. Comparison with Old Type COSMOSIL

1) New Type COSMOSIL (5C₁₈-MS-II) vs. Old Type COSMOSIL (5C₁₈ and 5C₁₈-MS)

Analysis of Metal Coordination Compounds

The metal coordination compounds, e.g., Oxine-copper, were not eluted from COSMOSIL 5C₁₈ because its silica gel contains a high level metal impurities. COSMOSIL 5C₁₈-MS or 5C₁₈-MS-II can separate the same metal coordination compounds because they are packed with high purity (99.99%) silica gel.

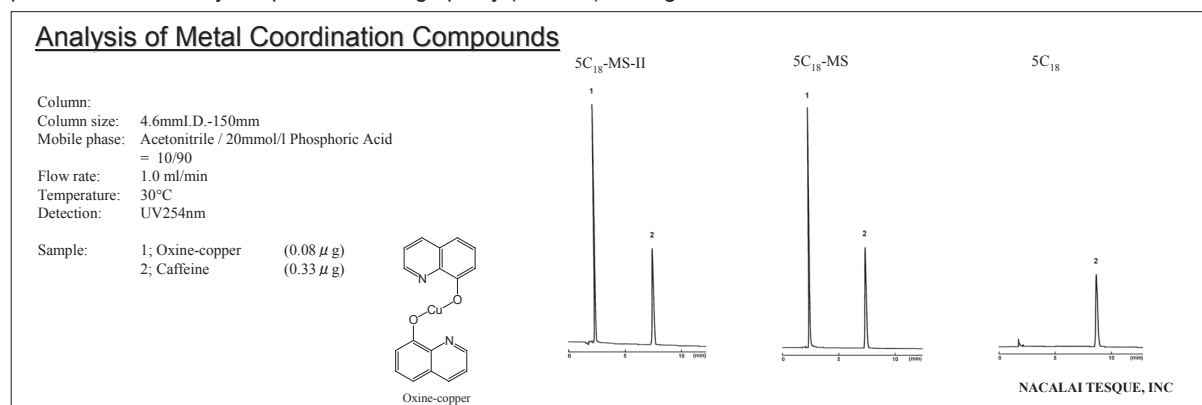

Analysis of Basic Compounds

COSMOSIL 5C₁₈-MS-II shows better separation for the basic compounds than COSMOSIL 5C₁₈-MS because COSMOSIL 5C₁₈-MS-II is treated with improved end-capping.

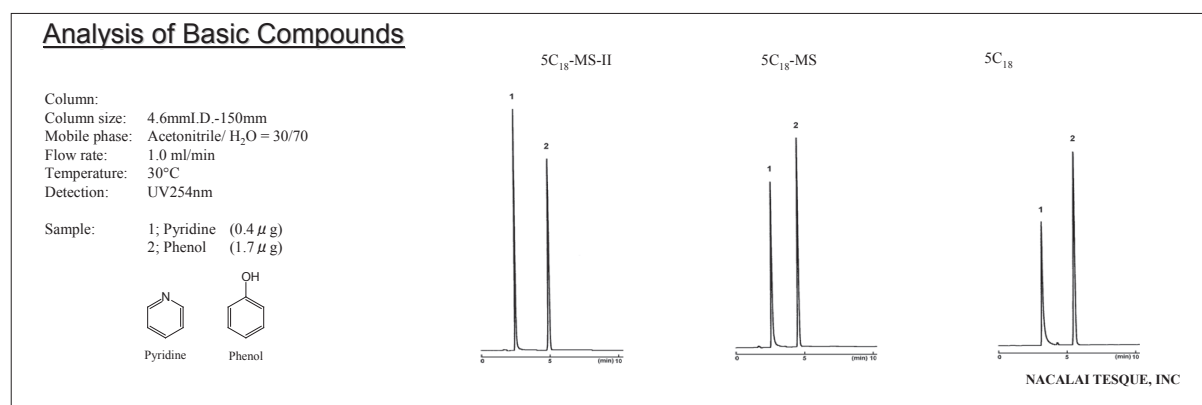

Selectivity

Little difference exists among COSMOSIL 5C₁₈, 5C₁₈-MS and 5C₁₈-MS-II in selectivity. The same analytical condition used for the old type column can be transferred to COSMOSIL 5C₁₈-MS-II without any modification.

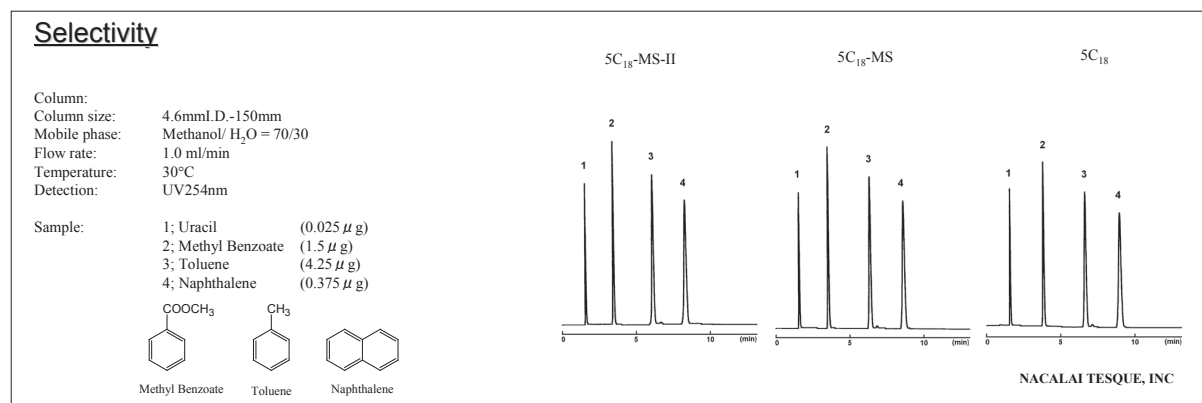

Technical Information

2) New Type COSMOSIL (5C₁₈-AR-II) vs. Old Type COSMOSIL (5C₁₈-AR)

Analysis of Metal Coordination Compounds

COSMOSIL-5C₁₈ AR-II shows better separation for the metal coordination compounds e.g., 8-Quinolol than COSMOSIL 5C₁₈-AR because of the high purity silica gel.

Analysis of Metal Coordination Compounds

Column:
Column size: 4.6mm I.D.-150mm
Mobile phase: Methanol/ 20mmol/l Phosphate
buffer(pH7) = 60/40
Flow rate: 1.0 ml/min
Temperature: 30°C
Detection: UV254nm

Sample: 1; Acetylacetone
2; 8-Hydroxyquinoline [δ -Quinolol]
3; Benzene

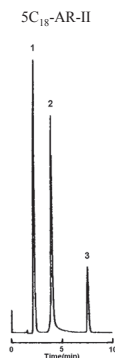

NACALAI TESQUE, INC

Acid Resistance

COSMOSIL 5C₁₈-AR-II show superior acid resistance to 5C₁₈-AR.

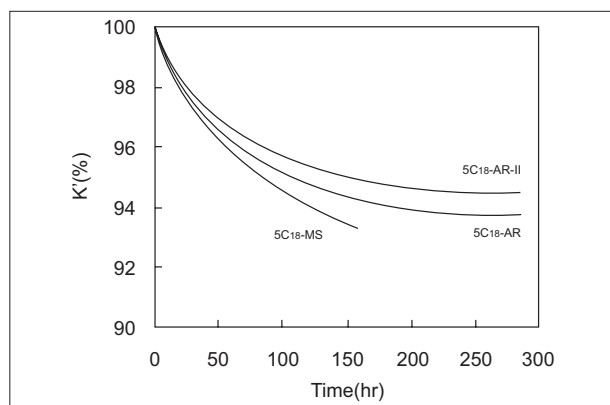

Degradation test with 0.1% Trifluoroacetic Acid at 60°C

Selectivity

The selectivity for non-dissociative organic compounds on COSMOSIL 5C₁₈ AR-II and COSMOSIL 5C₁₈ AR is identical because the carbon content of both columns is the same.

Selectivity

Column:
Column size: 4.6mm I.D.-150mm
Mobile phase: Methanol/ H₂O = 60/40
Flow rate: 1.0 ml/min
Temperature: 30°C
Detection: UV254nm

Sample: 1; Uracil
2; Acetophenone
3; Methyl Benzoate
4; Benzene
5; Toluene

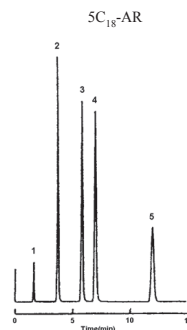
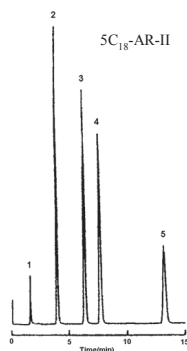

NACALAI TESQUE, INC

COSMOSIL 5C₁₈-MS-II and COSMOSIL 5C₁₈-AR-II support the validation.

New Types of COSMOSIL columns are recommended for your new applications.



Index



Sample Name Index	216
Packing Material's Name Index	226

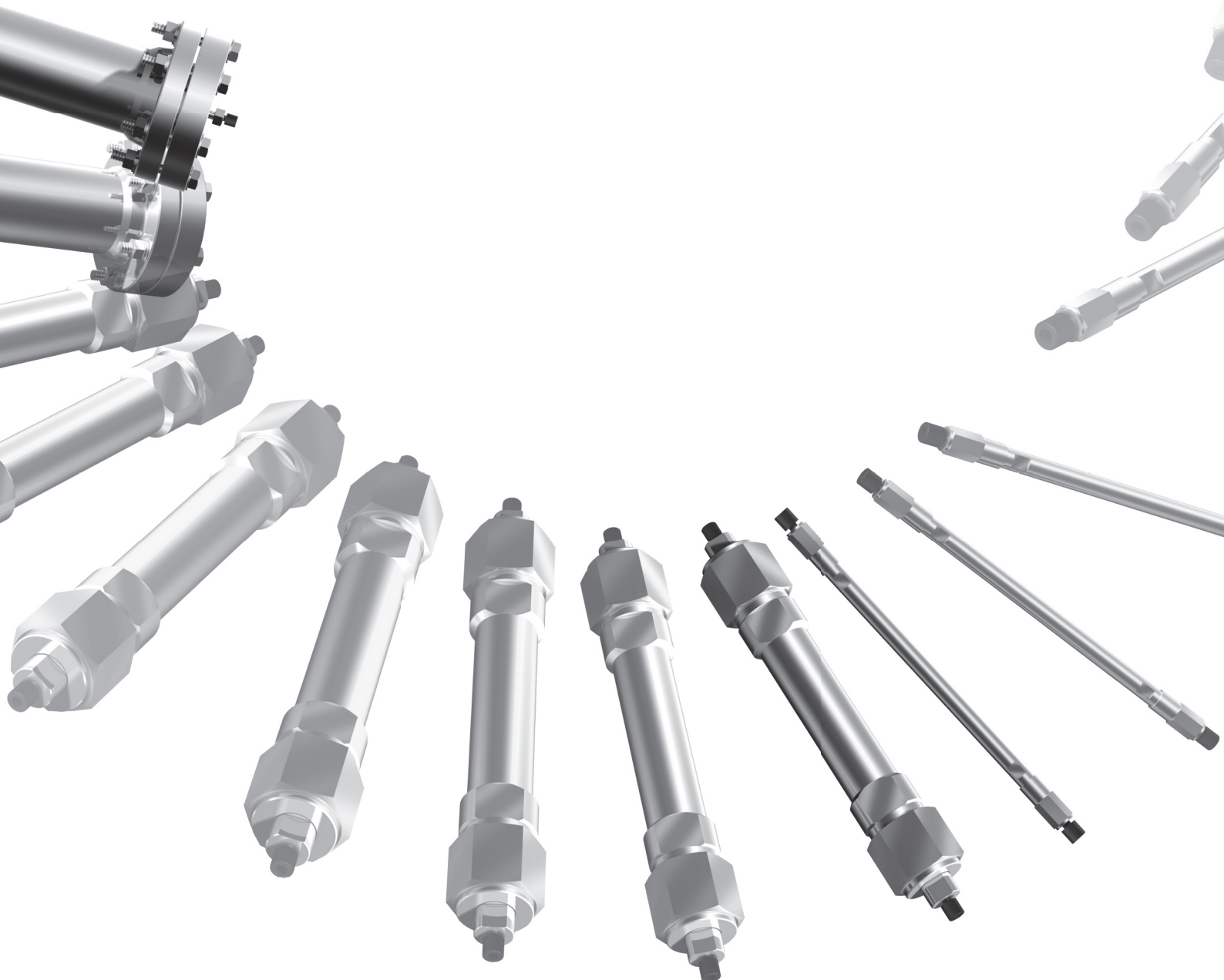

Sample Name Index

I. HPLC Columns		
A		
Acenaphthene	99, 161	
Acenaphthylene	161	
Acesulfame	135	
p-Acetamidophenol	15, 31, 92, 122	
Acetanilide	102, 111, 122	
Acetic Acid	18	
Acetil Acid	124	
Acetophenone	14, 30, 160, 214	
4'-Acetoxyacetanilide	31, 92	
Acetrizic Acid	93	
Acetylacetone	214	
N-Acetylprocainamide	14, 121	
Acetylsalicylic Acid [Aspirine]	122	
Acid Red 52	13, 135	
Aconitine	132	
Acrinol	92	
Acrylic Acid	79	
Actinase E	152	
Adenine	18, 147	
Adenosine	18, 112, 147	
Adenosine-5'-diphosphate	147	
Adenosine-5'-monophosphate	147	
Adenosine-5'-triphosphate	147	
L-Adrenaline	78	
Aflatoxin B1	132	
Aflatoxin B2	132	
Aflatoxin G1	132	
Aflatoxin G2	132	
Aildenafil	124	
[Ala2]-Leucine-Enkephalin	151	
[Ala2]-Methionine-Enkephalin	151	
Albiflorin	127	
Albumin, Bovine [BSA]	42, 51, 152	
Albumin, Egg [Ovalbumin]	42, 153	
Albumin, Goat	153	
Albumin, Human	152	
Albumin, Rabbit	153	
Alcohol Dehydrogenase	152	
Alizalin	131	
Allantoic Acid	124	
Allantoin	37, 124	
Allopurinol	141	
Allylbenzene	162	
Amaranth	13, 135	
Amikacin Sulfate 2,4,6-trinitrobenzenesulfonic Acid Derivative	93	
4-Amino-6-chloro-1,3-benzenedisulfonamide	110	
p-Aminoacetophenone	102, 110	
4-Aminoantipyrine	15, 122	
p-Aminobenzoic Acid	92	
4-Amino-n-butylric Acid [GABA]	150	
4-(Aminomethyl)benzoic Acid	106	
trans-4-(Aminomethyl)cyclohexanecarboxylic Acid [Tranexamic Acid]	106	
m-Aminophenol	161	
o-Aminophenol	161	
p-Aminophenol	31, 92, 161	
Aminotadalafil	124	
Amlodipine	93	
Ammelide	37	
Ammeline	37	
Amoxicillin	93, 96	
Ampicillin	93, 111, 123	
D-(-)-Amygdalin	126	
α-Amylase	152	
Amylbenzene	12, 21, 62, 131, 207	
4-Androstene-3,17-dione	140	
Angiotensin I (Human)	16, 150	
AngiotensinII	151	
Angiotensin II (Human)	16, 47, 150, 151	
Angiotensin II, [Asn ¹ ,Val ⁵]	151	
Angiotensin II, [Sar ¹ ,Ala ⁸]	151	
Angiotensin II, [Sar ¹ ,Ile ⁸]	151	
Angiotensin II, [Sar ¹ ,Thr ⁸]	151	
Angiotensin II, [Val ⁵]	151	
Angiotensin II, Des-Asp ¹ - [Ile ⁸]	151	
Aniline	160	
Anisole	160, 202	
Anthracene	22, 161, 204	
Anthrarufin	131	
Anti-6xHis(Mouse IgG1-k),	155	
Antipyrine	15, 122	
Apigenin	130	
Aprotinin	46	
D-(-)-Arabinose	39	
Arbutin	125	
[Arg8]-Vasopressin	95	
L-(+)-Ascorbic Acid [Vitamin C]	19, 137, 138	
Asn ¹ ,Val ⁵	151	
Aspartame	135	
L-Aspartic Acid	150	
Aspirine	122	
Asulam	133	
Atenolol	93	
Atrazine	134	
Atropine	128	
Atropine Sulfate	15, 129	
Azathioprine	92	
3'-Azido-3'-deoxythymidine [Zidovudine]	100	
Aztreonam	92	

B	
Baclofen	109
Baicalein	23, 70
Baicalin	70, 125, 127
Bamethane	114
Barbital	122, 129
BBP	158
Beclomethasone Dipropionate	98, 114, 115
Bensulide	133
Benzamide	160
Benz[a]anthracene	161, 205
Benzene	14, 21, 30, 31, 62, 157, 159, 160, 202, 204, 207, 214
Benzo[b]fluoranthene	161
Benzoic Acid	34, 92, 118, 135, 159
Benzonitrile	160
Benzo[g,h,i]perylene	161
Benzophenone	98, 100, 118, 119
Benzo[a]pyrene	161
Benz[a]pyrene	161
Benzyl Alcohol	9, 14, 118
Benzyl p-Hydroxybenzoate	110
2-Benzylpyridine	161
3-Benzylpyridine	161
4-Benzylpyridine	161
Berberine	25, 125
Betahisfine	115
Betamethasone	115, 141
Betamethasone 21-Phosphate	115
Betamethasone 17-Valerate	115, 200
Bezafibrate	114
BHT	136
Bibenzyl	22
1,1'-Binaphthyl	162
D-Biotin [Vitamin H]	137
Biphenyl	109, 136
Bisoprolol	110
Boc-(D)Phe-(L)Phe-OMe	150
Boc-(L)Phe-(L)Phe-OMe	150
Bombesin	151
Bovine Serum	154
BPMC	134
Bradykinin	151
Brilliant Blue FCF	13, 135
Bromacil	134
Bromhexine	114
Bromobenzene	157, 160, 206
Brucine	128, 129
BSA	42, 51, 152
Bufalin	127
Bufexamac	112
Butylbenzene	62, 207
n-Butylbenzene	12, 21, 62, 160
n-Butyl Benzoate	12
n-Butyl Benzyl Phthalate [BBP]	158
tert-Butylhydroquinone	136
3-tert-Butyl-4-hydroxyanisol	136
Butyl p-Hydroxybenzoate	16, 94, 96, 97, 98, 100, 110, 113, 115, 120, 129
Butyl Hydroxy Toluene	136
n-Butyl Salicylate	16
C	
(-)-C	23
C ₆₀	52, 54, 56, 57
C ₆₀ O	54
C ₇₀	52, 54, 56
C ₇₆	54, 56
C ₇₈	54
C ₈₄	54, 56
C ₈₆	55
Caffeine	23, 31, 68, 105, 108, 113, 117, 119, 121, 127, 137, 213
Calciferol	138
Calcium Folate	115, 116
Camostat	96
Campesterol	26
Capsaicin	27, 128, 132
Captopril	95
Carbamazepine	121, 122
Carbazochrome	96
Carbazochrome Sodium Sulfonate	96
Carbazole	33
Carbenicillin	123
S(-)-Carbidopa	96
Carbonic Anhydrase	45, 152
Carbosulfan	134
L-Carnitine	137
α-Carotene	130
β-Carotene	130, 135, 139
Carvylacetate (cis, trans)	161
CAT	134
Catalase	153
(-)-Catechin [(-)-C]	23
(-)-Catechin Gallate [(-)-Cg]	23
CDDR	123
Cefaclor	77, 102
Cefadroxil	102
Cefsulodin	102
Ceftazidime	102, 103
Ceftriaxone	103
Cephaeline	128
Cephalothin Sodium	102
Cetirizine	101
(-)-Cg	23
Chlomethoxynil	133

I. HPLC Columns	Chlormadinone Acetate	98	Crotonic Acid	77
	Chlorobenzene	157, 160, 206	Crude fullerenes	56
	4-Chlorobenzoic Acid	94, 114	Cyanazine	134
	4-Chlorobenzophenone	98	Cyanocobalamin	99, 116, 137
	Chloro IPC	134	Cyanocobalamin Derivative	99
	4-Chlorophenol	98	Cyanuric Acid	37
	m-Chlorophenol	156	α -Cyclodextrin	142
	o-Chlorophenol	156	β -Cyclodextrin	142
	p-Chlorophenol	97, 156	γ -Cyclodextrin	142
	4-(4-Chlorophenyl)-4-hydroxypiperidine	109	Cyclosporin	100
II. UHPLC Columns	1-(p-Chlorophenylsulfonyl)-3-propylurea [Chlorpropamide]	98	Cytidine	18, 147
	Chlorotoluron	134	Cytidine-5'-monophosphate	136
	Chlorpropamide	98	Cytochrome C	42, 48, 49, 151, 153
	Chloroxuron	134	Cytosine	18, 147
	Chlorpheniramine	98, 107		
	Chlortetracycline	123	D	
	Cholesterol	26	Dabsyl-Glycine	82
	Choline Oxidase	152	Dabsyl-L-Alanine	82
	Chondroitinase AC-II digested	144	Dabsyl-L-Leucine	82
	Chondroitin Sulfate A	144	Dabsyl-L-Valine	82
III. Preparative Packing Materials	Chondroitin Sulfate C	144	Daidzein	25
	Chrysazin	131	Daidzin	25
	Chrysene	161, 202	dAMP	147
	Chrysin	23	Dansyl Amino Acids	149
	α -Chymotrypsinogen A	45, 153	Dantrolene	103
	Ciclosporin [Cyclosporin]	100	Daunorubicin	95, 103
	Cilastatin	101	DBP	158
	Cimetidine	122	dCMP	147
	Cinchonidine	96	DCMU	133
	trans-Cinnamic Acid	129	DCEPA	133
IV. Related Products	Cinnamyl Alcohol	34	Deferoxamine	105
	Cinobufagin	127	DEHP	158
	Citric Acid	18, 137	Dehydroacetic Acid	135
	L-Citrulline	132	2'-Deoxyadenosine 5'-triphosphate	18
	Clarithromycin	97	2'-Deoxyadenosine-5'-monophosphate [dAMP]	147
	Clavulanic Acid	96	2'-Deoxycytidine 5'-monophosphate [dCMP]	147
	Clindamycin	77, 97	2'-Deoxycytidine 5'-triphosphate	18
	Clindamycin Phosphate	97	2'-Deoxyguanosine 5'-monophosphate [dGMP]	147
	Clobetasol Propionate	98	2'-Deoxyguanosine 5'-triphosphate	18
	Clofibrate	97, 98	Deoxyribonuclease I	153
V. Applications	Cloperastine	98	2'-Deoxythymidine 5'-triphosphate	18
	Cloxacillin	97	2'-Deoxyuridine	94
	CNP	133	Desipramine	121
	Coenzyme Q10 [Ubidecarenone]	118	Dexamethasone	104, 141
	Conalbumin	46, 153	dGMP	147
	Concanavalin A	153, 154	6,9-Diamino-2-ethoxyacridine Lactate [Acrinol]	92
	Coomassie Brilliant Blue G-250	162	Diaphorase	154
	Cortisone	24, 99, 141	Diatrizoic Acid	93
	Cortisone-21-Acetate	99, 113, 141	1,2:5,6-Dibenzanthracene	161
	Coumarin	131	Dibenzosuberone	162, 204
VI. Technical Notes	Creatinine	140	Dibenzosuberone	162, 204
	m-Cresol	118	Dibucaine	104
	p-Cresol	68		
VII. Index				

2,6-Di- <i>t</i> -butyl- <i>p</i> -cresol [Butyl Hydroxy Toluene;BHT]	136	DNA-wrapped CNT	58
Di- <i>n</i> -butyl Phthalate [DBP]	108, 158	1,5-DNN	203
Dichlorophenamide	100	1,8-DNN	203
Diclofenac	100	DNOP	158
DIDP	158	Dobutamine	106
Diethylene Glycol	159	Domperidone	107
<i>m</i> -Difluorobenzene	157	DOP	158
<i>o</i> -Difluorobenzene	157	L-DOPA	18, 78, 140
<i>p</i> -Difluorobenzene	157	Dopamine	18, 78, 106, 140
Digitoxigenin	123	Doxifluridine	105
Digitoxin	99, 123	Doxorubicin	95, 105
Digoxin	99	Doxycycline	105
3,4-Dihydrocoumarin	131		
Dihydroquinine	96	E	
7,8-Dihydroxyflavone	23	(-)-EC	23
3,4-Dihydroxyphenylacetic Acid	140	(-)-ECg	23
(-)-3-(3,4-Dihydroxyphenyl)-2-methyl-L-alanine [L- α -Methyl DOPA]		E.coli Proteins	155
.....	96	(-)-EGC	23
Diisodecyl Phthalate [DIDP]	158	(-)-EGCg	23
Diisononyl Phthalate [DINP]	158	Egg White	154, 155
Diketopiperazine	135	Elaidic Acid	145
Diltiazem	101	Emetine	128
Dimefuron	134	(-)-Epicatechin [(-)-EC]	23
4-Dimethylaminoantipyrine	101	(-)-Epicatechin Gallate [(-)-ECg]	23
Dimethylaminophenol	109	(-)-Epigallocatechin [(-)-EGC]	23
<i>N,N</i> -Dimethylaniline	160	(-)-Epigallocatechin Gallate [(-)-EGCg]	23
<i>N,N</i> -Dimethylbenzylamine	9	(\pm)-Epinephrine	18, 140
1,1-Dimethylbiguanide [Metformin]	117	Epirubicin	95
1,5-Dimethylnaphthalene	28, 203	L-(+)-Ergothioneine	37
1-(2,6-Dimethylphenoxy)-2-propanamine [Mexiletine]	116	meso-Erythrite	39, 142, 143, 159
2,4-Dinitroaniline	160	meso-Erythritol [meso-Erythrite]	39, 142, 143, 159
1,2-Dinitrobenzene	95	Erythrosine B	13, 135
3,5-Dinitrobenzoic Acid <i>n</i> -Butyl Ester	83	17 α -Estradiol	140
3,5-Dinitrobenzoic Acid <i>n</i> -Heptyl Ester	83	17 β -Estradiol	140
3,5-Dinitrobenzoic Acid <i>n</i> -Hexyl Ester	83	Estradiol Benzoate	95
3,5-Dinitrobenzoic Acid <i>n</i> -Octyl Ester	83	Estriol	95, 140
3,5-Dinitrobenzoic Acid <i>n</i> -Pentyl Ester	83	Estrone	140
3,5-Dinitrobenzoic Acid <i>n</i> -Propyl Ester	83	Ethidimuron	134
1,5-Dinitronaphthalene	28	Ethinylestradiol	120
1,8-Dinitronaphthalene	28	Ethiofencarb	134
1,5-Dinitronaphthalene [1,5-DNN]	203	Ethofumesate	134
1,8-Dinitronaphthalene [1,8-DNN]	203	3-Ethoxy-4-Hydroxybenzaldehyde	116
DINP	158	6-Ethoxy-2,2,4-Trimethyl 1,2-Dihydroquinoline	136
Di- <i>n</i> -octyl Phthalate [DNOP]	158	<i>o</i> -Ethoxybenzamide	107
Diocetyl Phthalate [DOP] [DEHP]	158	<i>p</i> -Ethoxyphenol	97
5,5-Diphenylhydantoin	121, 122	Ethylbenzene	21, 62, 160, 207
Diphenhydramine	122	<i>p</i> -Ethylbenzoic Acid	159
4,5-Diphenylimidazole	112	Ethyl 4-Hydroxybenzoate	114
Diphenylmethane	162	Ethyl <i>p</i> -Hydroxybenzoate	16, 96, 99, 100, 101, 107, 112, 160
Diphenyl Phthalate	107	<i>p</i> -Ethylphenol	68
Dipyridamole	100	<i>o</i> -Ethylpyridine	160
Disulfiram	100	Ethyl Salicylate	16, 160
DNA	148		

	I. HPLC Columns	II. UHPLC Columns	III. Preparative Packing Materials	IV. Related Products	V. Applications	VI. Technical Notes	VII. Index
	Ethyl Vanillin [3-Ethoxy-4-Hydroxybenzaldehyde] 116						
	F						
	FAD 112						
	Famotidine 111, 122						
	Fast Green FCF 13, 135						
	Fibrinogen 153						
	Fisetin 23						
	Flavin Adenine Dinucleotide [FAD] 112						
	Flavin Mononucleotide [FMN] 112, 137						
	Flavone 23						
	Flopropione 114						
	Flumequine 123						
	Fluocinolone Acetonide 112, 113, 141						
	Fluocinolone Acetonide 21-Acetate 112						
	Fluoranthene 161						
	Fluorene 161, 162						
	Fluorobenzene 157, 160						
	(+)-5-Fluoro-5'-deoxyuridine [Doxifluridine] 105						
	Fluorodifen 133						
	Fluorometholone 113, 141						
	Fluoxymesterone 112						
	Flurbiprofen 113, 123						
	Folic Acid 115, 116, 117, 137						
	1-Fructofuranosyl-D-nystose 40						
	D-(-)-Fructose 39, 40, 142, 143						
	D-Fructose-6-phosphate 144						
	Fullerene toluene extract 53						
	Fumaric Acid 18, 110						
	Furan 160						
	Furfural 160						
	Furfuryl Alcohol 160						
	G						
	GABA 150						
	Gabexate Mesilate 96						
	D-(+)-Galactose 39						
	β -Galactosidase 48						
	Gallic Acid 16, 125						
	(-)-Galocatechin [(-)-GC] 23						
	(-)-Galocatechin Gallate [(-)-GCg] 23						
	(-)-GC 23						
	(-)-GCg 23						
	Gd@C ₈₂ (I) 55						
	Geniposide 125, 127						
	Genistein 25						
	Genistin 25						
	Gentisic Acid 16						
	6-Gingerol 132						
	Ginkgolide A 132						
	Ginkgolide B 132						
	Ginkgolide C 132						
	Ginsenoside Rb1 126						
	Ginsenoside Rc 126						
	Ginsenoside Re 126						
	Ginsenoside Rg1 126						
	Gitoxin 99						
	D-Glucitol 39, 143						
	D-Glucitol [Sorbitol] 143						
	D-(+)-Glucose 38, 39, 40, 142, 143, 144						
	Glucose Oxidase 46, 152						
	α -D-Glucose-1-phosphate 144						
	D-Glucose-6-phosphate 144						
	β -Glucosidase 51						
	L-Glutamic Acid 150						
	L-Glutamic Dehydrogenase 152						
	DL-Glyceric Acid 159						
	Glycerol 39, 158, 159						
	Glycine 36						
	Glycitein 25						
	Glycitin 25						
	Glycolic Acid 18						
	Glycylglycine 36						
	Glycyrrhizic Acid [Glycyrrhizin] 125, 136						
	Glycyrrhizin 125, 136						
	(+)-Griseofulvin 97						
	Guaiacol 156						
	Guaiacol Glycerol Ether 93, 97						
	Guanine 18, 147						
	Guanosine 18, 123, 147						
	Guanosine-5'-monophosphate 136						
	H						
	Haloperidol 109						
	HeLa Cell Proteins 155						
	Hemoglobin Bovine 44, 51						
	Hemoglobin, Human 47						
	Hesperidin 129						
	Hibenzic Acid 104						
	Hinokitiol 131						
	Hippuric Acid 140						
	His-tag Protein in 20mmol/l Tris buffer(pH8.0) 50						
	L-Histidine 79						
	Homosildenafil 124						
	Homovanillic Acid 18						
	Hongdenafil 124						
	Honokiol 126						
	Human Serum 47, 154						
	Hyaluronic Acid 144						
	Hydralazine 122						
	Hydrochlorothiazide 110						
	Hydrocortisone 24, 110, 141						
	Hydrocortisone Acetate 99, 110						

Hydrocortisone 21-Hemisuccinate	110	Josamycin	101
Hydroquinidine	96		
Hydroquinone	125	K	
Hydroxocobalamin Acetate	116	Kanamycin Sulfate 2,4,6-Trinitrobenzenesulfonic Acid Derivative	93
p-Hydroxybenzoic Acid	99, 107	1-Kestose	40
3-Hydroxyflavone	23, 131	Ketamine	121
5-Hydroxyflavone	23, 131	Ketoprofen	99, 123
6-Hydroxyflavone	23, 131		
7-Hydroxyflavone	23, 131	L	
Hydroxyhomosildenafil	124	Lactic Acid	18
Hydroxyhongdenafil	124	β-Lactoglobulin	51
17α-Hydroxyprogesterone 17-Acetate	98	Lactose	41, 143
8-Hydroxyquinoline [8-Quinololin]	214	Latamoxef (isomer 1)	118
Hypoxanthine	141	Latamoxef (isomer 2)	118
		Lauric Acid p-Bromophenacyl Ester	82
I		L-Leucine	39
Ibuprofen	98, 123	Leucine-Enkephalin	151
Idoxuridine	94	Levallorphan	120
Imazalil	136	Levothyroxine [L-Thyroxine]	120
Imidazosagatriadinone	124	Lidocaine	119, 121
Imipramine	121	Lincomycin	97, 120
Indeno[1,2,3-c,d]pyrene	161	Linolenic Acid p-Bromophenacyl Ester	146
Indigo Carmine	13, 135	γ-Linolenic Acid p-Bromophenacyl Ester	146
Indometacin [Indomethacin]	94, 127	Linuron	133, 134
Indomethacin	94, 127	Lisinopril	119
Inosine-5'-monophosphate	136	Ile ⁸	151
myo-Inositol	39, 143	Luteolin	23
Insulin	45	Lysozyme	42, 49, 153
Iodobenzene	160	Lysyl Endopeptidase digested	151
5-Iododeoxyuridine [Idoxuridine]	94		
5-Iodouracil	94	M	
Ipratropium Bromide	94	Magnolol	126
Ipratropium Bromide Derivative	94	Maleic Acid	18, 98, 104
Iprodione	133	L-(-)-Malic Acid	18, 132, 138
Isoamyl Benzoate	200	Maltitol	39, 142, 143
D-Isoascorbic Acid	137	Maltoheptaose	40
Isobutyl 4-Hydroxybenzoate	120	Maltohexaose	40
Isobutyl p-Hydroxybenzoate	93, 117	Maltopentaose	40
L-Isoleucine	37	Maltose	38, 39, 40, 41, 142, 143
Isomaltooligosaccharides	142	Maltotertaitol	143
Isonicotinamide	102	Maltotetraose	40
Isonicotinic Acid [Pyridine-4-carboxylic Acid]	94	Maltotriitol	143
Isonicotinic Hydrazide [Isoniazid]	94	Maltotriose	40, 143
Isophthalonitrile	26, 203	Mandelic Acid	140
Isoprocab	134	Maneb	133
Isopropyl p-Hydroxybenzoate	103, 112	D-(-)-Mannitol	143
Isoproturon	134	D-Mannosamine	40
Isosuprine	94	D-(+)-Mannose	40
		MCC	133
		MCP	133

	I. HPLC Columns	II. UHPLC Columns	III. Preparative Packing Materials	IV. Related Products	V. Applications	VI. Technical Notes	VII. Index
MCPB	133						
MCPD	133						
Mecobalamin	116						
Melamine	37						
Menatetrenone	117						
Mepivacaine	118						
5-Mercapto-1-methyltetrazole	118						
6-Mercaptopurine	92						
Meropenem	118						
Metabromuron	134						
Metazachlor	134						
Methabenzthiazuron	134						
Methicillin	123						
Methionine-Enkephalin	151						
Methomyl	134						
Methotrexate	117						
6-Methoxyflavone	23						
DL-3-Methoxy-4-hydroxymandelic Acid	18						
m-Methoxyphenol	156						
p-Methoxyphenol	156						
o-Methoxyphenol [Guaiacol]	156						
3-Methoxytyramine	140						
2-(2-Methylaminoethyl)pyridine [Betahistine]	115						
Methyl Benzoate	14, 30, 72, 95, 103, 160, 190						
N-Methylbenzylamine	9						
L- α -Methyl DOPA	96						
Methyl p-Hydroxybenzoate	16, 97, 105, 106, 108, 109, 111, 115, 117, 119, 125						
Methyl Linoleate	145						
Methyl Linolenate	145						
Methyl Margarate	145						
1-Methylnaphthalene	28, 203						
Methyl Nonadecanoate	145						
Methyl Oleate	145						
6 α -Methylprednisolone	112						
Methyl Salicylate	16, 160						
Methyl Stearate	145						
17-Methyltestosterone	140						
Meticrane	117						
Metoxuron	134						
Metronidazole	117						
Mexiletine	116						
Milk	152						
Minocycline	116						
4-epi-Minocycline	116						
Mitomycin C	116						
Mizoribine	116						
Monolinuron	134						
MPMC	134						
MTMC	134						
Myoglobin	42, 46, 51, 153						
Myosin	151						
Myricetin	23						
Myristic Acid p-Bromophenacyl Ester	82						
N							
Nabumetone	108						
NAC	134						
Nalidixic Acid	108						
Naphazoline Nitrate	107						
Naphthalene	28, 161, 190, 203, 204, 213						
2-Naphthalenesulfonic Acid	95, 103						
Naringenin	130						
Naringin	128, 129, 130						
NBD-L-Alanine	83						
NBD-Glycine	83						
NBD-L-Leucine	83						
NBD-L-Valine	83						
Neostigmine Methyl Sulfate	109						
Neurotensin	151						
New Coccine	13, 135						
Nicardipine	108						
Nicergoline	109						
Nicotinamide	108, 137						
Nicotinic Acid	105, 108, 137						
Nifedipine	108						
Nitrendipine	109						
p-Nitroaniline	160						
Nitrobenzene	160, 202						
p-Nitrobenzyl Alcohol	34, 71						
Nitrofen	133						
Nitrofurantoin	124						
Nitrofurazone	124						
p-Nitrophenol	114						
L-Noradrenaline	18, 78, 140						
Nystose	40						
O							
Octadecanoic Acid	145						
Ofloxacin	123						
Oleic Acid	145						
Omeprazole	95						
OPA-Glycine	83						
OPA-L-Alanine	83						
OPA-L-Leucine	83						
OPA-L-Valine	83						
Ovalbumin	42, 153						
Oxalic Acid	159						
Oxamic Acid	159						
Oxine-copper	14, 213						
Oxolinic Acid	123						
Oxyfluorfen	133						
Oxytetracycline	123						
Oxytocin	16, 150						

Oxytocin Acetate	95	Polyoxyethylene Lauryl Ether	162
		Pravastatin	112
P		Prednisolone	24, 107, 113, 141
PAC	134	Prednisolone 21-Acetate	113, 141
Paeoniflorin	127	Prednisone	110, 141
Paeonol	8, 129	Procainamide	14, 121
PA-Glucose Oligomer	144	Procaine	113
Palatinit	143	Procaterol	113
Palatinose	142	Progesterone	95
Palmatine	25, 125	Prometryn	134
Palmitic Acid p-Bromophenacyl Ester	82	Propazine	134
D-Pantothenic Acid	137	Propionic Acid	18
Papaverine	132	Propranolol	114
PCBB	57	Propylbenzene	62, 207
PCBM	57	n-Propylbenzene	21, 62, 160, 162
pd(T) ₁₂₋₁₈	148	Propyl Benzoate	112
Penicillin G	115, 123	n-Propyl Gallate	136
Perfluorotetradecanoic Acid	159	n-Propyl p-Hydroxybenzoate	16, 100, 103, 104, 109, 112, 119, 125, 136, 160
Peroxidase	46, 153	Propyl p-Hydroxybenzoate	101
Perylene	162	n-Propyl Salicylate	16
PHC	134	Prostaglandin D ₂	141
Phenacetin	15, 122, 126	Prostaglandin E ₂	141
Phenanthrene	161	Prostaglandin F _{2α}	141
Phenol	99, 118, 121, 160, 213	Prostaglandin I ₂	141
Phenyl Benzoate	101	Protocatechuic Acid	16
Phenolphthalein	160	PTH-Arg	149
L-(–)-Phenylalanine	79	PTH-Asp	149
[6,6]-Phenyl-C ₆₁ Butyric Acid Butyl Ester [PCBB]	57	PTH-His	149
[6,6]-Phenyl-C ₆₁ Butyric Acid Methyl Ester [PCBM]	57	PTH-Lys	149
β-Phenylethylamine	116	PTH-Ser	149
2-Phenylethyl-β-cellobioside	19	PTH-Trp	149
2-Phenylethyl-β-gentiobioside	19	Puerarin	125
2-Phenylethyl-β-lactoside	19	Purpurin	131
2-Phenylethyl-β-maltoside	19	Pyrene	161
2-Phenylethyl-β-melibioside	19	Pyridine	103, 160, 213
o-Phenylphenol	136	Pyridine-4-carboxylic Acid	94
Phenytoin [5,5-Diphenylhydantoin]	121, 122	Pyridoxine	137
Phloxine B	13, 135	Pyruvate Kinase	153
L-α-Phosphatidyl Choline	146		
L-α-Phosphatidylethanolamine	146	Q	
L-α-Phosphatidylinositol	146	Quercetin	23
L-α-Phosphatidyl-L-serine	146	Quinidine	96, 121
Phthalic Acid	16, 106, 110	Quinine	96
Phthalonitrile	26, 203	Quinizarin	71, 131
Pimaricin	111	8-Quinolinol	214
Piperacillin	111		
Piperonyl Butoxide	136	R	
Pirimicarb	134	D-(+)-Raffinose	39, 142
Piromidic Acid	123	Ranitidine	122
cis-Platin [CDDP]	123	Rebaudioside A	40
Poly-L-Glutamic Acid Sodium Salt	43		
Polyoxyethylene Hexadecyl Ether	158, 161		

I. HPLC Columns	Recombinant human tau	154	Styrene Oxide	160
	Reserpine	120, 132	Substance P	16, 150, 151
	Resibufogenin	127	Succinic Acid	18
	all-trans-Retinoic Acid	139	Sucrose	39, 41, 142, 143
	13-cis-Retinoic Acid	139	Sulbactam	101
	L-(+)-Rhamnose	39, 40	Sulfachloropyridazine	124
	Riboflavin	112, 137	Sulfadimethoxine	124
	Ribonuclease A	42, 48, 49, 153	Sulfaisomidin	124
	Rifampicin	120	Sulfamethazine	124
	Ritodrine	119	Sulfamethoxazole	124
II. UHPLC Columns	threo-Ritodrine	119	Sulfamethoxypyridazine	124
	Rose Bengal	13, 135	Sulfamonomethoxine	124
	Roxatidine Acetate	121	Sulfathiazole	94, 124
	Roxithromycin	121	Sunset Yellow FCF	13, 135
			Swertiamarin	128
III. Preparative Packing Materials	S		T	
	Saccharin	135	Tadalafil	124
	Saikosaponin a	63, 126, 130	Tartaric Acid	18
	Saikosaponin b ₁	63, 130	Tartrazine	13, 135
	Saikosaponin b ₂	63, 127, 130	Taurine	150
	Saikosaponin c	63, 130	Terbutylazine	134
	Saikosaponin d	63, 126, 130	Terbutryn	134
	Saikosaponin h	63	Terephthalic Acid Diethyl Ester	103
	Salicylamide	34, 71, 106	Terephthalonitrile	26, 203
	Salicylic Acid	34, 71, 99, 118, 122	m-Terphenyl	156
IV. Related Products	α-Santonin	99	o-Terphenyl	12, 21, 156
	Sar ¹ ,Ala ⁸	151	p-Terphenyl	100, 156
	Sar ¹ ,Ile ⁸	151	Testosterone	140
	Sar ¹ ,Thr ⁸	151	Testosterone Propionate	114, 140
	Sc ₂ @C ₇₆ (I)	55	Tetracycline	123
	Sc ₂ @C ₇₈	55	Tetraethylthiuram Disulfide [Disulfiram]	100
	Sc ₂ @C ₈₀ (I)	55	Tetraphene [Benz[a]anthracene]	153, 205
	Scopolamine	15, 111, 129	Theobromine	31, 67, 68, 121
	(-)-Scopolamine n-Butyl Bromide	111	Theophylline	31, 67, 68, 103, 118, 121, 128
	Sennoside A	127, 128	Thermolysin	152
V. Applications	Sennoside B	127	Thiamine	103, 126, 137
	6-Shogaol	132	2-(4-Thiazolyl)benzimidazole	136
	Sildenafil	124	Thioaldenafil	124
	Sitosterol	26	Thioanisole	160
	Sodium Copper Chlorophyllin	131, 135	Thiodenafil	124
	Sodium Iron Chlorophyllin	135	Thiopental	103
	Sorbic Acid	77, 135, 137	Thiopental (Isomer)	103
	Sorbitol	143	Thioquinapiperil	124
	Soybean milk	152	Thiram	133
	Stearic Acid [Octadecanoic Acid]	145	Thymidine	18, 147
VI. Technical Notes	Stearic Acid p-Bromophenacyl Ester	82	Thymine	18, 100, 147
	Stevioside	40	Thyroglobulin	46, 153
	Stigmasterol	26	L-Thyroxine	120
	cis-Stilbene	157	Ticarcillin	104
	trans-Stilbene	157	Tiglic Acid	77
	Streptomycin Sulfate	124	Timolol	104
	Strychnine	129		
VII. Index				

Tipepidine	104
α-Tocopherol	27, 63, 105, 138, 139
DL-α-Tocopherol	70, 138
β-Tocopherol	27, 63, 138, 139
γ-Tocopherol	27, 63, 138, 139
δ-Tocopherol	27, 63, 138, 139
DL-α-Tocopherol Acetate	70, 105, 138
(±)-α-Tocopherol Nicotinate	105
α-Tocotrienol	138, 139
β-Tocotrienol	138, 139
γ-Tocotrienol	138, 139
δ-Tocotrienol	138, 139
Todalazine	106, 122
Tolazamide	106
Tolbutamide	106
Tolnaftate	13, 107
Toluene	14, 21, 30, 31, 62, 157, 160, 190, 206, 207, 213, 214
o-Toluic Acid	104, 159
m-Tolunitrile	24, 202
o-Tolunitrile	24, 202
p-Tolunitrile	24, 202
N-(m-Toluoyl)glycine	140
N-(o-Toluoyl)glycine	140
N-(p-Toluoyl)glycine	140
Tranexamic Acid	106
Transferrin	45, 47, 152
D-(+)-Trehalose	41, 142
Triamcinolone	106, 141
Triamcinolone Acetonide	107, 113, 141
2',4',6'-Trihydroxypropiophenone [Flopropione]	114
3,3',5'-Triiodo-L-thyronine	119
Trimetazidine	107
1-(2,3,4-Trimethoxybenzyl)piperazine [Trimetazidine]	107
Triphenylene	12, 21
Tris(hydroxymethyl)aminomethane	159
Triton X-100	29
Trypsin Inhibitor	45, 48
Trypsin Inhibitor from Soybean	50
Trypsinogen	45
L- Tryptophan	79
L- Tyrosine	79

U

Ubidecarenone	118
Udenafil	124
Uracil	9, 18, 106, 121, 122, 147, 158, 159, 160, 190, 213, 214
Urea	159
Urease	155
Uric Acid	141
Uridine	18, 147, 158
Uridine-5'-monophosphate	136

V

cis-Vaccenic Acid	145
trans-Vaccenic Acid	145
Val ⁵	151
Valerophenone	12
L-Valine	37
Vancomycin	109
N-Vanillylnonanamide	27, 128
Vardenafil	124
Vincristine Sulfate	111
Vinyl Acetate	129
2-Vinylpyridine	115
N-Vinyl-2-pyrrolidone	129
Vitamin A	139
Vitamin A Acetate, all-trans	135, 138
Vitamin A Acid, all-trans [all-trans-Retinoic Acid]	139
Vitamin B ₁ [Thiamine]	103, 126, 137
Vitamin B ₂ [Riboflavin]	112, 137
Vitamin B ₆ [Pyridoxine]	137
Vitamin B ₁₂ [Cyanocobalamin]	99, 116, 137
Vitamin C	19, 137, 138
Vitamin D ₂ [Calciferol]	138
Vitamin D ₃	138
Vitamin E [DL-α-Tocopherol]	72, 138
Vitamin E Acetate [DL-α-Tocopherol Acetate]	72, 105, 138
Vitamin H	137
Vitamin K ₁	117, 138
Vitamin K ₃	138
Vitamin P [Hesperidin]	129

W

Wogonin	70
---------------	----

X

Xanthene	104
Xanthine	141
Xanthoanthrafil	124
XMC	134
p-Xylene	34
Xylitol	39, 142, 143
Xylooligosaccharides	142
D-(+)-Xylose	40

Z

Zidovudine	100
------------------	-----

Packing Material's Name Index

COSMOSIL C₁₈-MS-II

I. HPLC Columns	Acesulfame	135	Betahistine	115
	p-Acetamidophenol	15, 31, 92	Betamethasone	115, 141
	Acetanilide	111	Betamethasone 21-Phosphate	115
II. UHPLC Columns	Acetophenone	14, 30, 160	Betamethasone 17-Valerate	115, 200
	4'-Acetoxyacetanilide	31, 92	BHT	136
	Acetrizoic Acid	93	D-Biotin [Vitamin H]	137
	N-Acetylprocainamide	14	Biphenyl	136
	Acid Red 52	13, 135	Boc-(D)Phe-(L)Phe-OMe	150
	Aconitine	132	Boc-(L)Phe-(L)Phe-OMe	150
	Acrylic Acid	79	BPMC	134
	Adenosine	112	Brilliant Blue FCF	13, 135
	Alizalin	131	Bromacil	134
III. Preparative Packing Materials	Amaranth	13, 135	Bromhexine	114
	4-Aminoantipyrine	15	Bromobenzene	157, 160, 206
	p-Aminophenol	31, 92	Butylbenzene	62, 207
	Amlodipine	93	n-Butylbenzene	12, 21, 62, 160
	Ampicillin	93, 111, 123	n-Butyl Benzoate	12
	D-(-)-Amygdalin	126	n-Butyl Benzyl Phthalate [BBP]	158
	Amylbenzene	12, 21, 62, 131, 207	tert-Butylhydroquinone	136
	Aniline	160	3-tert-Butyl-4-hydroxyanisol	136
	Anisole	160, 202	Butyl p-Hydroxybenzoate	94, 96, 97, 98, 100, 110, 113, 115, 129
IV. Related Products	Anthracene	204	Butyl Hydroxy Toluene	136
	Anthrarufin	131	(-)-C	23
	Antipyrine	15	C ₆₀	52
	Apigenin	130	C ₇₀	52
	[Arg8]-Vasopressin	95	Caffeine	23, 31, 113, 117, 119, 127, 213
	L(+)-Ascorbic Acid [Vitamin C]	137	Calcium Folate	115, 116
	Aspartame	135	Campesterol	26
V. Applications	Asulam	133	Capsaicin	27
	Atrazine	134	Captopril	95
	Atropine Sulfate	15	Carbamazepine	121, 122
	3'-Azido-3'-deoxythymidine [Zidovudine]	100	Carbenicillin	123
	Baicalein	23	Carbosulfan	134
	Baicalin	127	α-Carotene	130
	Bamethane	114	β-Carotene	130
	Barbital	122	CAT	134
	BBP	158	(-)-Catechin [(-)-C]	23
	Beclomethasone Dipropionate	98, 114, 115	(-)-Catechin Gallate [(-)-Cg]	23
	Bensulide	133	Cefaclor	77, 102
	Benzamide	160	Cefadroxil	102
	Benz[a]anthracene	205	Ceftazidime	103
	Benzene	14, 21, 30, 31, 62, 157, 159, 160, 202, 204, 207	Ceftriaxone	103
	Benzoic Acid	118, 135, 159	Cephaeline	128
	Benzonitrile	160	Cephalothin Sodium	102
	Benzophenone	100	(-)-Cg	23
	Benzyl Alcohol	9, 14	Chlomethoxynil	133
	Benzyl p-Hydroxybenzoate	110	Chlormadinone Acetate	98
	Berberine	25	Chlorobenzene	157, 160, 206
			4-Chlorobenzoic Acid	94
			Chloro IPC	134

COSMOSIL C₁₈-MS-II

m-Chlorophenol	156	7,8-Dihydroxyflavone	23
o-Chlorophenol	156	Diisodecyl Phthalate [DIDP]	158
p-Chlorophenol	156	Diisononyl Phthalate [DINP]	158
Chlorotoluron	134	Diketopiperazine	135
Chloroxuron	134	Diltiazem	101
Chlortetracycline	123	Dimefuron	134
Cholesterol	26	Dimethylaminophenol	109
Chrysazin	131	N,N-Dimethylaniline	160
Chrysene	205	N,N-Dimethylbenzylamine	9
Chrysin	23	1,5-Dimethylnaphthalene	28, 203
Cimetidine	122	2,4-Dinitroaniline	160
Clarithromycin	97	3,5-Dinitrobenzoic Acid n-Butyl Ester	83
Clindamycin	77, 97	3,5-Dinitrobenzoic Acid n-Heptyl Ester	83
Clobetasol Propionate	98	3,5-Dinitrobenzoic Acid n-Hexyl Ester	83
Cloxacillin	97	3,5-Dinitrobenzoic Acid n-Octyl Ester	83
CNP	133	3,5-Dinitrobenzoic Acid n-Pentyl Ester	83
Coomassie Brilliant Blue G-250	162	3,5-Dinitrobenzoic Acid n-Propyl Ester	83
Cortisone	24, 99, 141	1,5-Dinitronaphthalene [1,5-DNN]	28, 203
Cortisone-21-Acetate	99, 113, 141	1,8-Dinitronaphthalene [1,8-DNN]	28, 203
Coumarin	131	DINP	158
Creatinine	140	Di-n-octyl Phthalate [DNOP]	158
m-Cresol	118	Diethyl Phthalate [DOP] [DEHP]	158
Crotonic Acid	77	Diphenhydramine	122
Cyanazine	134	5,5-Diphenylhydantoin	121, 122
Cyanocobalamin	137	Disulfiram	100
Dabsyl-Glycine	82	1,5-DNN	28, 203
Dabsyl-L-Alanine	82	1,8-DNN	28, 203
Dabsyl-L-Leucine	82	DNOP	158
Dabsyl-L-Valine	82	Dobutamine	106
Daidzein	25	DOP	158
Daidzin	25	Dopamine	106
Dansyl Amino Acids	149	Doxorubicin	105
Daunorubicin	103	Doxycycline	105
DBP	158	(-)-EC	23
DCMU	133	(-)-ECg	23
DCPA	133	(-)-EGC	23
DEHP	158	(-)-EGCg	23
Dehydroacetic Acid	135	Elaidic Acid	145
Desipramine	121	Emetine	128
Dexamethasone	141	(-)-Epicatechin [(-)-EC]	23
Diatrizoic Acid	93	(-)-Epicatechin Gallate [(-)-ECg]	23
Dibenzosuberone	204	(-)-Epigallocatechin [(-)-EGC]	23
Dibenzosuberone	204	(-)-Epigallocatechin Gallate [(-)-EGCg]	23
2,6-Di-t-butyl-p-cresol [Butyl Hydroxy Toluene;BHT]	136	Erythrosine B	13, 135
Di-n-butyl Phthalate [DBP]	108, 158	17 α -Estradiol	140
Dichlorophenamide	100	17 β -Estradiol	140
DIDP	158	Estradiol Benzoate	95
m-Difluorobenzene	157	Estriol	95
o-Difluorobenzene	157	Ethidimuron	134
p-Difluorobenzene	157	Ethiofencarb	134
3,4-Dihydrocoumarin	131	Ethofumesate	134
		6-Ethoxy-2,2,4-trimethyl 1,2-Dihydroquinoline	136
		Ethylbenzene	21, 62, 160, 207

I. HPLC Columns

II. UHPLC Columns

III. Preparative Packing Materials

IV. Related Products

V. Applications

VI. Technical Notes

VII. Index

COSMOSIL C₁₈-MS-II

	I. HPLC Columns	II. UHPLC Columns	III. Preparative Packing Materials	IV. Related Products	V. Applications	VI. Technical Notes	VII. Index
	p-Ethylbenzoic Acid 159						
	Ethyl p-Hydroxybenzoate 96, 99, 101, 112, 160						
	Ethyl Salicylate 160						
	FAD 112						
	Famotidine 122						
	Fast Green FCF 13, 135						
	Fisetin 23						
	Flavin Adenine Dinucleotide [FAD] 112						
	Flavin Mononucleotide [FMN] 112, 137						
	Flavone 23						
	Flumequine 123						
	Fluocinolone Acetonide 141						
	Fluocinolone Acetonide 21-Acetate 112						
	Fluorobenzene 157, 160						
	Fluorodifen 133						
	Fluorometholone 113, 141						
	Flurbiprofen 123						
	FMN 112, 137						
	Folic Acid 115, 116, 117, 137						
	Fullerene toluene extract 53						
	Furan 160						
	Furfural 160						
	Furfuryl Alcohol 160						
	Gabexate Mesilate 96						
	(-)-Gallic acid [(-)-GC] 23						
	(-)-Gallic acid Gallate [(-)-GCg] 23						
	(-)-GC 23						
	(-)-GCg 23						
	Geniposide 127						
	Genistein 25						
	Genistin 25						
	6-Gingerol 132						
	Ginkgolide A 132						
	Ginkgolide B 132						
	Ginkgolide C 132						
	Ginsenoside Rb1 126						
	Ginsenoside Rc 126						
	Glycitein 25						
	Glycitin 25						
	(+)-Griseofulvin 97						
	Guaiacol 156						
	Guaiacol Glycerol Ether 93, 97						
	Hibenzic Acid 104						
	Hippuric Acid 140						
	L-Histidine 79						
	Hydralazine 122						
	Hydrocortisone 24, 110, 141						
	Hydrocortisone Acetate 99, 110						
	Hydrocortisone 21-Hemisuccinate 110						
	p-Hydroxybenzoic Acid 107						
	3-Hydroxyflavone 23, 131						
	5-Hydroxyflavone 23, 131						
	6-Hydroxyflavone 23, 131						
	7-Hydroxyflavone 23, 131						
	17 α -Hydroxyprogesterone 17-Acetate 98						
	Ibuprofen 123						
	Imazalil 136						
	Imipramine 121						
	Indigo Carmine 13, 135						
	Indometacin [Indomethacin] 94						
	Indomethacin 94						
	Iodobenzene 160						
	Iprodione 133						
	Isoamyl Benzoate 200						
	Isobutyl p-Hydroxybenzoate 93						
	Isoniazid 94						
	Isonicotinic Acid [Pyridine-4-carboxylic Acid] 94						
	Isonicotinic Hydrazide [Isoniazid] 94						
	Isophthalonitrile 26, 203						
	Isoprocab 134						
	Isopropyl p-Hydroxybenzoate 103						
	Isoproturon 134						
	Isoxsuprine 94						
	Ketamine 121						
	Ketoprofen 123						
	Latamoxef (isomer 1) 118						
	Latamoxef (isomer 2) 118						
	Lauric Acid p-Bromophenacyl Ester 82						
	Lidocaine 121						
	Linuron 133, 134						
	Lisinopril 119						
	Luteolin 23						
	Mandelic Acid 140						
	Maneb 133						
	MCC 133						
	MCP 133						
	MCPB 133						
	MCPP 133						
	Menatetrenone 117						
	5-Mercapto-1-methyltetrazole 118						
	Metabromuron 134						
	Metazachlor 134						
	Methabenzthiazuron 134						
	Methicillin 123						
	Methomyl 134						
	Methotrexate 117						
	6-Methoxyflavone 23						
	m-Methoxyphenol 156						
	p-Methoxyphenol 156						
	o-Methoxyphenol [Guaiacol] 156						
	2-(2-Methylaminoethyl)pyridine [Betahistine] 115						
	Methyl Benzoate 14, 30, 95, 160, 213						
	N-Methylbenzylamine 9						
	Methyl p-Hydroxybenzoate 106, 115, 117						

COSMOSIL C₁₈-MS-II

Methyl Linoleate	145	Palmitic Acid p-Bromophenacyl Ester	80
Methyl Linolenate	145	D-Pantothenic Acid	137
Methyl Margarate	145	Papaverine	132
1-Methylnaphthalene	28, 203	Penicillin G	115, 123
Methyl Nonadecanoate	145	PHC	134
Methyl Oleate	145	Phenacetin	15
Methyl Salicylate	160	Phenol	118, 160, 213
Methyl Stearate	145	Phenolphthalein	160
Meticrane	117	Phenyl Benzoate	101
Metoxuron	134	L-(-)-Phenylalanine	77
Metronidazole	117	o-Phenylphenol	136
Monolinuron	134	Phenytoin [5,5-Diphenylhydantoin]	121, 122
MPMC	134	Phloxine B	13, 135
MTMC	134	L- α -Phosphatidyl Choline	146
Myricetin	23	L- α -Phosphatidylethanolamine	146
Myristic Acid p-Bromophenacyl Ester	82	L- α -Phosphatidylinositol	146
NAC	134	L- α -Phosphatidyl-L-serine	146
Naphthalene	28, 203, 204, 213	Phthalic Acid	106
2-Naphthalenesulfonic Acid	103	Phthalonitrile	26, 203
Naringenin	130	Pimaricin	111
Naringin	128, 130	Piperacillin	111
NBD-Glycine	83	Pirimicarb	134
NBD-L-Alanine	83	Piromidic Acid	123
NBD-L-Leucine	83	Pravastatin	112
NBD-L-Valine	83	Prednisolone	24, 107, 113, 141
Neostigmine Methyl Sulfate	109	Prednisolone 21-Acetate	113, 141
New Coccine	13, 135	Prednisone	141
Nicardipine	108	Procainamide	14
Nicergoline	109	Procaine	113
Nicotinamide	108, 137	Progesterone	95
Nicotinic Acid	105, 108, 137	Prometryn	134
Nifedipine	108	Propazine	134
Nitrendipine	109	Propranolol	114
p-Nitroaniline	160	Propylbenzene	62, 207
Nitrobenzene	160, 202	n-Propylbenzene	21, 62, 160
Nitrofen	133	Propyl Benzoate	112
Octadecanoic Acid	145	n-Propyl Gallate	136
Ofloxacin	123	n-Propyl p-Hydroxybenzoate	103, 104, 109, 160
Oleic Acid	145	Prostaglandin D ₂	141
OPA-Glycine	83	Prostaglandin E ₂	141
OPA-L-Alanine	83	Prostaglandin F _{2α}	141
OPA-L-Leucine	83	Prostaglandin I ₂	141
OPA-L-Valine	83	Puerarin	125
Oxine-copper	14, 213	Purpurin	131
Oxolinic Acid	123	Pyridine	103, 160, 213
Oxyfluorfen	133	Pyridine-4-carboxylic Acid	94
Oxytetracycline	123	Pyridoxine	137
Oxytocin Acetate	95	Quercetin	23
PAC	134	Quinidine	121
Paeonol	8, 129	Quinizarin	131
Palmitate	25	Ranitidine	122
		Reserpine	132
		all-trans-Retinoic Acid	139

I. HPLC Columns

II. UHPLC Columns

III. Preparative
Packing Materials

IV. Related Products

V. Applications

VI. Technical Notes

VII. Index

COSMOSIL C₁₈-MS-II

I. HPLC Columns	13-cis-Retinoic Acid	139
	Riboflavin	112, 137
	Rose Bengal	13, 135
	Roxatidine Acetate	121
	Saccharin	135
	Saikosaponin a	126, 130
	Saikosaponin b ₁	130
	Saikosaponin b ₂	127, 130
	Saikosaponin c	130
	Saikosaponin d	126, 130
II. UHPLC Columns	Salicylamide	106
	Salicylic Acid	118
	α-Santonin	99
	Scopolamine	15
	Senoside A	127, 128
	Senoside B	127
	6-Shogaol	132
	Sitosterol	26
	Sodium Copper Chlorophyllin	131
	Sorbic Acid	77, 135
III. Preparative Packing Materials	Stearic Acid [Octadecanoic Acid]	145
	Stearic Acid p-Bromophenacyl Ester	82
	Stigmasterol	26
	cis-Stilbene	157
	trans-Stilbene	157
	Streptomycin Sulfate	124
	Styrene Oxide	160
	Sulbactam	101
	Sulfachloropyridazine	124
	Sulfadimethoxine	124
IV. Related Products	Sulfaisomidin	124
	Sulfamethazine	124
	Sulfamethoxazole	124
	Sulfamethoxypyridazine	124
	Sulfamonomethoxine	124
	Sulfathiazole	124
	Sunset Yellow FCF	13, 135
	Swertiamarin	128
	Tartrazine	13, 135
	Terbutylazine	134
V. Applications	Terbutryn	134
	Terephthalic Acid Diethyl Ester	103
	Terephthalonitrile	26, 203
	m-Terphenyl	156
	o-Terphenyl	12, 21, 156
	p-Terphenyl	156
	Testosterone Propionate	114
	Tetracycline	123
	Tetraethylthiuram Disulfide [Disulfiram]	100
	Tetraphene [Benz[a]anthracene]	205
VI. Technical Notes	Theobromine	31
	Theophylline	31, 118, 128
	Thiamine	137
	2-(4-Thiazolyl)benzimidazole	136
	Thioanisole	160
	Thiopental	103
	Thiopental (Isomer)	103
	Thiram	133
	Thymine	100
	Tiglic Acid	79
VII. Index	Tipepidine	104
	α-Tocopherol	27, 105, 138, 139
	DL-α-Tocopherol	138
	β-Tocopherol	27, 138, 139
	γ-Tocopherol	27, 138, 139
	δ-Tocopherol	27, 138, 139
	DL-α-Tocopherol Acetate	105, 138
	(±)-α-Tocopherol Nicotinate	105
	α-Tocotrienol	138, 139
	β-Tocotrienol	138, 139
γ-Tocotrienol	138, 139	
δ-Tocotrienol	138, 139	
Todralazine	106, 122	
Tolnaftate	13	
Toluene	14, 21, 30, 31, 62, 157, 160, 206, 207, 213	
o-Toluic Acid	159	
m-Tolunitrile	24, 202	
o-Tolunitrile	24, 202	
p-Tolunitrile	24, 202	
N-(o-Toluoyl)glycine	140	
Triamcinolone	106, 141	
Triamcinolone Acetonide	107, 141	
1-(2,3,4-Trimethoxybenzyl)piperazine [Trimetazidine]	107	
Trimetazidine	107	
Triphenylene	12	
Triton X-100	29	
L- Tryptophan	79	
L- Tyrosine	79	
Uracil	9, 106, 122, 159, 160, 213	
cis-Vaccenic Acid	145	
trans-Vaccenic Acid	145	
Valerophenone	12	
Vancomycin	109	
N-Vanillynonanamide	27	
2-Vinylpyridine	115	
Vitamin A Acetate, all-trans	138	
Vitamin A Acid, all-trans [all-trans-Retinoic Acid]	139	
Vitamin B ₁ [Thiamine]	137	
Vitamin B ₂ [Riboflavin]	112, 137	
Vitamin B ₆ [Pyridoxine]	137	
Vitamin B ₁₂ [Cyanocobalamin]	137	
Vitamin C	137	
Vitamin D ₂ [Calciferol]	138	
Vitamin D ₃	138	

COSMOSIL C₁₈-MS-II

Vitamin E [DL- α -Tocopherol]	138
Vitamin E Acetate [DL- α -Tocopherol Acetate]	105, 138
Vitamin H	137
Vitamin K ₁	117, 138
Vitamin K ₃	138
Xanthene	104
XMC	134
Zidovudine	100

COSMOSIL C₁₈-AR-II

Acenaphthene	161
Acenaphthylene	161
p-Acetamidophenol	122
Acetanilide	102
Acetophenone	214
Acetylacetone	214
N-Acetylprocainamide	121
Acetylsalicylic Acid [Aspirine]	122
Acid Red 52	135
Aflatoxin B ₁	132
Aflatoxin B ₂	132
Aflatoxin G ₁	132
Aflatoxin G ₂	132
Albiflorin	127
Allopurinol	141
Amaranth	135
p-Aminoacetophenone	110
4-Aminoantipyrine	122
p-Aminobenzoic Acid	92
4-Amino-6-chloro-1,3-benzenedisulfonamide	110
Amylbenzene	12
4-Androstene-3,17-dione	140
Angiotensin I (Human)	16
Angiotensin II (Human)	16, 151
Angiotensin II, [Asn ¹ ,Val ⁵]	151
Angiotensin II, [Sar ¹ ,Ala ⁸]	151
Angiotensin II, [Sar ¹ ,Ile ⁸]	151
Angiotensin II, [Sar ¹ ,Thr ⁸]	151
Angiotensin II, [Val ⁵]	151
Angiotensin II, Des-Asp ¹ - [Ile ⁸]	151
Anthracene	22, 161
Antipyrine	122
Asn ¹ ,Val ⁵	151
Aspirine	122
Atenolol	93
Azathioprine	92
Aztreonam	92
Baclofen	109
Baicalin	125
Benz[a]anthracene	161

Benzene	214
Benzo[b]fluoranthene	161
Benzoic Acid	92
Benzo[g,h,i]perylene	161
Benzophenone	98, 118, 119
Benzo[a]pyrene	161
Benz[a]pyrene	161
Benzyl Alcohol	118
Bezafibrate	114
Bibenzyl	22
Biphenyl	109
Brilliant Blue FCF	135
Bufalin	127
Bufexamac	112
n-Butylbenzene	12
n-Butyl Benzoate	12
Butyl p-Hydroxybenzoate	16, 96, 120
n-Butyl Salicylate	16
Caffeine	105, 108, 121
Camostat	96
Carbazole	33
Ceftazidime	102
4-Chlorobenzoic Acid	114
4-Chlorobenzophenone	98
4-Chlorophenol	98
4-(4-Chlorophenyl)-4-hydroxypiperidine	109
1-(p-Chlorophenylsulfonyl)-3-Propylurea [Chlorpropamide]	98
Chlorpheniramine	107
Chlorpropamide	98
Chrysene	161
Cilastatin	101
trans-Cinnamic Acid	129
Cinobufagin	127
Clofibrate	98
Cloperastine	98
Cytidine-5'-monophosphate	136
Cytochrome C	151
dAMP	147
dCMP	147
Deferoxamine	105
2'-Deoxyadenosine-5'-Monophosphate [dAMP]	147
2'-Deoxycytidine 5'-Monophosphate [dCMP]	147
2'-Deoxyguanosine 5'-Monophosphate [dGMP]	147
dGMP	147
1,2:5,6-Dibenzanthracene	161
Dibucaine	104
Diclofenac	100
Digitoxigenin	123
Digitoxin	123
3,4-Dihydroxyphenylacetic Acid	140
N,N-Dimethylaniline	160
1,1-Dimethylbiguanide [Metformin]	117
4,5-Diphenylimidazole	112

I. HPLC Columns

II. UHPLC Columns

III. Preparative
Packing Materials

IV. Related Products

V. Applications

VI. Technical Notes

VII. Index

COSMOSIL C₁₈-AR-II

I. HPLC Columns	L-DOPA	140
	Dopamine	140
	Doxifluridine	105
	(±)-Epinephrine	140
	Erythrosine B	135
	17β-Estradiol	140
	Estriol	140
	Estrone	140
	Ethinylestradiol	120
	o-Ethoxybenzamide	107
II. UHPLC Columns	Ethyl 4-Hydroxybenzoate	114
	Ethyl p-Hydroxybenzoate	16, 100, 112
	o-Ethylpyridine	160
	Ethyl Salicylate	16
	Famotidine	111
	Fast Green FCF	135
	Fluocinolone Acetonide	112
	Fluoranthene	161
	Fluorene	161
	(+)-5-Fluoro-5'-deoxyuridine [Doxifluridine]	105
III. Preparative Packing Materials	Flurbiprofen	113
	Gallic Acid	16
	Geniposide	125
	Gentisic Acid	16
	Glycyrrhizic Acid [Glycyrrhizin]	125, 136
	Glycyrrhizin	125, 136
	Guanosine-5'-monophosphate	136
	Haloperidol	109
	Hibenzic Acid	104
	Hinokitiol	131
IV. Related Products	Honokiol	126
	Hydrochlorothiazide	110
	p-Hydroxybenzoic Acid	99
	8-Hydroxyquinoline [8-Quinololinol]	214
	Hypoxanthine	141
	Ibuprofen	98
	Ile ⁸	151
	Indeno[1,2,3-c,d]pyrene	161
	Indigo Carmine	135
	Indometacin [Indomethacin]	127
V. Applications	Indomethacin	127
	Inosine-5'-monophosphate	136
	Isobutyl 4-Hydroxybenzoate	120
	Isobutyl p-Hydroxybenzoat	117
	Isopropyl p-Hydroxybenzoate	112
	Josamycin	101
	Ketoprofen	99
	Levallophan	120
	Levothyroxine [L-Thyroxine]	120
	Lidocaine	119
VI. Technical Notes	Lysyl Endopeptidase digested	151
	Magnolol	126
	Mepivacaine	118
	6-Mercaptopurine	92
	Meropenem	118
	Metformin	117
	3-Methoxytyramine	140
	Methyl Benzoate	103, 190, 214
	Methyl p-Hydroxybenzoate	16, 105, 108, 109, 111, 119, 125
	Methyl Salicylate	16
VII. Index	17-Methyltestosterone	140
	Nabumetone	108
	Nalidixic Acid	108
	Naphazoline Nitrate	107
	Naphthalene	161, 187
	Naringin	129
	New Coccine	135
	Nicotinic Acid	104
	Nitrofurantoin	124
	Nitrofurazone	124
p-Nitrophenol	114	
L-Noradrenaline	140	
Oxytocin	16	
Paeoniflorin	127	
Perfluorotetradecanoic Acid	159	
Phenacetin	122	
Phenanthrene	161	
Phenol	99, 121	
Phloxine B	135	
Phthalic Acid	16, 110	
Piperonyl Butoxide	136	
Poly-L-glutamic Acid Sodium Salt	43	
Procainamide	121	
Procaterol	113	
n-Propyl p-Hydroxybenzoate	16, 100, 112, 125, 136	
n-Propyl Salicylate	16	
Protocatechuic Acid	16	
PTH-Arg	149	
PTH-Asp	149	
PTH-His	149	
PTH-Lys	149	
PTH-Ser	149	
PTH-Trp	149	
Pyrene	161	
8-Quinololinol	214	
Reserpine	120	
Resibufogenin	127	
Ritodrine	119	
threo-Ritodrine	119	
Rose Bengal	135	
Salicylic Acid	99, 122	
Sodium Copper Chlorophyllin	135	
Sodium Iron Chlorophyllin	135	
Substance P	16	

COSMOSIL C₁₈-AR-II

Sunset Yellow FCF	135
Tartrazine	135
o-Terphenyl	12
Testosterone	140
Testosterone Propionate	140
Theobromine	121
Theophylline	121
L-Thyroxine	120
Tipepidine	104
Toluene	190, 214
2',4',6'-Trihydroxypropiophenone [Flopropione]	114
Triphenylene	12
Uracil	121, 190, 214
Uric Acid	141
Uridine-5'-monophosphate	136
Val ⁵	151
Valerophenone	12
Vitamin B ₁ [Thiamine]	103
Vitamin P [Hesperidin]	129
Xanthine	141

COSMOSIL C₁₈-PAQ

Acenaphthene	99
Acetic Acid	18
Adenine	18, 147
Adenosine	18, 147
Adenosine-5'-diphosphate	147
Adenosine-5'-monophosphate	147
Adenosine-5'-triphosphate	147
L-Adrenaline	76
Amikacin Sulfate 2,4,6-trinitrobenzenesulfonic Acid Derivative	93
p-Aminoacetophenone	102
4-Amino-n-butyric Acid [GABA]	150
4-(Aminomethyl)benzoic Acid	106
trans-4-(Aminomethyl)cyclohexanecarboxylic Acid [Tranexamic Acid]	106
m-Aminophenol	161
o-Aminophenol	161
p-Aminophenol	161
Amoxicillin	93, 96
Amylbenzene	12
Arbutin	125
L(+)-Ascorbic Acid [Vitamin C]	19
L-Aspartic Acid	150
Atropine	128
Atropine Sulfate	129
Barbital	129
Berberine	125
Brucine	128, 129
n-Butylbenzene	12
n-Butyl Benzoate	12

Caffeine	119, 137
Carbazochrome	96
Carbazochrome Sodium Sulfonate	96
S(-)-Carbidopa	96
L-Carnitine	137
Cefaclor	102
Cefsulodin	102
Chlorpheniramine	98
Ciclosporin [Cyclosporin]	100
Cinchonidine	96
Citric Acid	18, 137
Clavulanic Acid	96
Coenzyme Q10 [Ubidecarenone]	118
Cyanocobalamin	116
Cytidine	18, 147
Cytosine	18, 147
2'-Deoxyadenosine 5'-triphosphate	18
2'-Deoxycytidine 5'-triphosphate	18
2'-Deoxyguanosine 5'-triphosphate	18
2'-Deoxythymidine 5'-triphosphate	18
2'-Deoxyuridine	94
6,9-Diamino-2-ethoxyacridine Lactate [Acrinol]	92
DIDP	158
Digitoxin	99
Digoxin	99
Dihydroquinine	96
(-)-3-(3,4-Dihydroxyphenyl)-2-methyl-L-alanine [L- α -Methyl DOPA]	96
Diisodecyl Phthalate [DIDP]	158
Diisononyl Phthalate [DINP]	158
DINP	158
Diphenyl Phthalate	107
L-DOPA	18, 96
Dopamine	18, 96
(\pm)-Epinephrine	18
Flavin Mononucleotide [FMN]	137
Fumaric Acid	18
GABA	150
Gallic Acid	125
Ginsenoside Re	126
Ginsenoside Rg1	126
Gitoxin	99
L-Glutamic Acid	150
Glycine	36
Glycolic Acid	18
Glycylglycine	36
Guanine	18, 147
Guanosine	18, 147
Homovanillic Acid	18
Hydroquinidine	96
Hydroquinone	125
Hydroxocobalamin Acetate	116
Idoxuridine	94

I. HPLC Columns

II. UHPLC Columns

III. Preparative
Packing Materials

IV. Related Products

V. Applications

VI. Technical Notes

VII. Index

COSMOSIL C₁₈-PAQ

I. HPLC Columns	5-Iododeoxyuridine [Idoxuridine]	94
	5-Iodouracil	94
	Isonicotinamide	102
	Kanamycin Sulfate 2,4,6-trinitrobenzenesulfonic Acid Derivative	93
	Lactic Acid	18
	Latamoxef (isomer 1)	118
	Latamoxef (isomer 2)	118
	Lisinopril	119
	Maleic Acid	18, 98
	L-(-)-Malic Acid	18
	Mecobalamin	116
	DL-3-Methoxy-4-hydroxymandelic Acid	18
	L- α -Methyl DOPA	96
	Mizoribine	116
	Nicotinamide	137
	L-Noradrenaline	18, 78
	PA-Glucose Oligomer	144
	Palmitate	125
	Phenacetin	126
	2-Phenylethyl- β -cellobioside	19
	2-Phenylethyl- β -gentiobioside	19
	2-Phenylethyl- β -lactoside	19
	2-Phenylethyl- β -maltoside	19
	2-Phenylethyl- β -melibioside	19
	Propionic Acid	18
	n-Propyl p-hydroxybenzoate	119
	Pyridoxine	137
	Quinidine	96
	Quinine	96
	Roxithromycin	121
	Scopolamine	129
	Senoside A	128
	Strychnine	129
	Succinic Acid	18
	Sulfathiazole	94
	Tartaric Acid	18
	o-Terphenyl	12
	Thiamine	126, 137
	Thymidine	18, 147
	Thymine	18, 147
	Tolnaftate	107
	3,3',5-Triiodo-L-thyronine	119
	Triphenylene	12
	Uracil	18, 147
	Uridine	18, 147
	Valerophenone	12
	Vitamin B ₁ [Thiamine]	126, 137
	Vitamin B ₆ [Pyridoxine]	137
	Vitamin B ₁₂ [Cyanocobalamin]	116
	Vitamin C	19

COSMOSIL Cholester

Amylbenzene	21, 207
Angiotensin I (Human)	150
Angiotensin II (Human)	150
Anthracene	22
Apigenin	130
Baicalein	23
Benz[a]anthracene	205
Benzene	21, 207
Bibenzyl	22
Bromobenzene	157
Butylbenzene	207
n-Butylbenzene	21
(-)-C	23
(-)-Cg	23
Caffeine	23
α -Carotene	130
β -Carotene	130
(-)-Catechin [(-)-C]	23
(-)-Catechin Gallate [(-)-Cg]	23
Chlorobenzene	157
m-Chlorophenol	156
o-Chlorophenol	156
p-Chlorophenol	156
Chondroitinase AC-II digested	144
Chondroitin Sulfate A	144
Chondroitin Sulfate C	144
Chrysene	205
Chrysin	23
7,8-Dihydroxyflavone	23
(-)-EC	23
(-)-ECg	23
(-)-EGC	23
(-)-EGCg	23
Elaidic Acid	145
(-)-Epicatechin [(-)-EC]	23
(-)-Epicatechin Gallate [(-)-ECg]	23
(-)-Epigallocatechin [(-)-EGC]	23
(-)-Epigallocatechin Gallate [(-)-EGCg]	23
Ethylbenzene	21, 207
Fisetin	23
Flavone	23
(-)-Galocatechin [(-)-GC]	23
(-)-Galocatechin Gallate [(-)-GCg]	23
(-)-GC	23
(-)-GCg	23
Guaiacol	156
3-Hydroxyflavone	23
5-Hydroxyflavone	23
6-Hydroxyflavone	23
7-Hydroxyflavone	23
Linolenic Acid p-Bromophenacyl Ester	146

COSMOSIL Cholester

γ-Linolenic Acid p-Bromophenacyl Ester	146
Luteolin	23
6-Methoxyflavone	23
m-Methoxyphenol	156
p-Methoxyphenol	156
o-Methoxyphenol [Guaiacol]	156
Methyl Linoleate	145
Methyl Linolenate	145
Methyl Margarate	145
Methyl Nonadecanoate	145
Methyl Oleate	145
Methyl Stearate	145
Myricetin	23
Naringenin	130
Naringin	130
Octadecanoic Acid	145
Oleic Acid	145
Oxytocin	150
n-Propylbenzene	21
Propylbenzene	207
Quercetin	23
13-cis-Retinoic Acid	139
all-trans-Retinoic Acid	139
Saikosaponin a	63, 130
Saikosaponin b ₁	63, 130
Saikosaponin b ₂	63, 130
Saikosaponin c	63, 130
Saikosaponin d	63, 130
Saikosaponin h	63
Stearic Acid [Octadecanoic Acid]	145
cis-Stilbene	157
trans-Stilbene	157
Substance P	150
m-Terphenyl	156
o-Terphenyl	21, 156
p-Terphenyl	156
Tetraphene [Benz[a]anthracene]	205
Toluene	21, 157, 207
Triphenylene	21
cis-Vaccenic Acid	145
trans-Vaccenic Acid	145
Vitamin A Acid, all-trans [all-trans-Retinoic Acid]	139
Vitamin D ₂ [Calciferol]	138
Vitamin D ₃	138

COSMOSIL πNAP

Adenine	147
Adenosine	147
Anisole	202
Benzene	157, 202

Berberine	25
Betamethasone	141
Campesterol	26
Capsaicin	27, 132
Cholesterol	26
Cortisone	24, 141
Cortisone-21-Acetate	141
Cytidine	147
Cytosine	147
Daidzein	25
Daidzin	25
Dexamethasone	141
m-Difluorobenzene	157
o-Difluorobenzene	157
p-Difluorobenzene	157
Fluocinolone Acetonide	141
Fluorobenzene	157
Fluorometholone	141
Genistein	25
Genistin	25
Glycitein	25
Glycitin	25
Guanine	147
Guanosine	147
Hydrocortisone	24, 141
Isophthalonitrile	26
Nitrobenzene	202
Palmitate	25
Phthalonitrile	26
Prednisolone	24, 141
Prednisolone 21-Acetate	141
Sitosterol	26
Stigmasterol	26
Terephthalonitrile	26
Thymidine	147
Thymine	147
α-Tocopherol	27, 63, 138, 139
β-Tocopherol	27, 63, 138, 139
γ-Tocopherol	27, 63, 138, 139
δ-Tocopherol	27, 63, 138, 139
α-Tocotrienol	138, 139
β-Tocotrienol	138, 139
γ-Tocotrienol	138, 139
δ-Tocotrienol	138, 139
m-Tolunitrile	24
o-Tolunitrile	24
p-Tolunitrile	24
Triamcinolone	141
Triamcinolone Acetonide	141
Uracil	147
Uridine	147
N-Vanillylnonanamide	27

I. HPLC Columns	COSMOSIL PYE	
	Amylbenzene	207
	Anisole	202
	Anthracene	204
	Benz[a]anthracene	205
	Benzene	202, 204, 207
	2-Benzylpyridine	161
	3-Benzylpyridine	161
	4-Benzylpyridine	161
	Bromobenzene	206
	Butylbenzene	207
	C ₆₀	52
	C ₇₀	52
	Campesterol	26
	Capsaicin	27
	Carvylacetate (cis, trans)	161
	Chlorobenzene	206
	Cholesterol	26
	Chrysene	205
	Dibenzosuberone	204
	Dibenzosuberone	204
	1,5-Dimethylnaphthalene	28, 203
	1,5-Dinitronaphthalene [1,5-DNN]	28, 203
	1,8-Dinitronaphthalene [1,8-DNN]	28, 203
	1,5-DNN	28, 203
	1,8-DNN	28, 203
	Ethylbenzene	207
	Isophthalonitrile	26, 203
	1-Methylnaphthalene	28, 203
	Naphthalene	28, 203, 204
	Nitrobenzene	202
	Phthalonitrile	26, 203
	Propylbenzene	207
	Sitosterol	26
	Stigmasterol	26
	Terephthalonitrile	26, 203
	Tetraphene [Benz[a]anthracene]	205
	α-Tocopherol	27
	β-Tocopherol	27
	γ-Tocopherol	27
	δ-Tocopherol	27
	Toluene	206, 207
	m-Tolunitrile	202
	o-Tolunitrile	202
	p-Tolunitrile	202
	N-(m-Toluoyl)glycine	140
	N-(o-Toluoyl)glycine	140
	N-(p-Toluoyl)glycine	140
	N-Vanillylnonanamide	27

COSMOSIL NPE	
Amylbenzene	207
Benzene	157, 207
Butylbenzene	207
C ₆₀	52, 57
C ₇₀	52
m-Difluorobenzene	157
o-Difluorobenzene	157
p-Difluorobenzene	157
1,5-Dimethylnaphthalene	28, 203
1,5-Dinitronaphthalene [1,5-DNN]	28, 203
1,8-Dinitronaphthalene [1,8-DNN]	28, 203
1,5-DNN	28, 203
1,8-DNN	28, 203
Ethylbenzene	207
Fluorobenzene	157
Isophthalonitrile	203
1-Methylnaphthalene	28, 203
Naphthalene	28, 203
PCBB	57
PCBM	57
[6,6]-Phenyl-C ₆₁ Butyric Acid Butyl Ester [PCBB]	57
[6,6]-Phenyl-C ₆₁ Butyric Acid Methyl Ester [PCBM]	57
Phthalonitrile	203
Propylbenzene	207
Terephthalonitrile	203
Toluene	207
m-Tolunitrile	202
o-Tolunitrile	202
p-Tolunitrile	202

COSMOSIL PBB-R	
Acetil Acid	124
Aildenafil	124
Allylbenzene	162
Aminotadalafil	124
Amylbenzene	207
Anthracene	204
Benzene	204, 207
1,1'-Binaphthyl	162
Bromobenzene	206
Butylbenzene	207
Chlorobenzene	206
Dibenzosuberone	162, 204
Dibenzosuberone	162, 204
Diphenylmethane	162
Ethylbenzene	207
Fluorene	162
Homosildenafil	124
Hongdenafil	124
Hydroxyhomosildenafil	124

COSMOSIL PBB-R

Hydroxyhongdenafil	124
Imidazosagatriadinone	124
Naphthalene	204
Perylene	162
Polyoxyethylene Hexadecyl Ether	158, 161
Polyoxyethylene Lauryl Ether	162
n-Propylbenzene	162
Propylbenzene	207
Sildenafil	124
Tadalafil	124
Thioaldenafil	124
Thiodenafil	124
Thioquinapiperfil	124
Toluene	206, 207
Triton X-100	29
Udenafil	124
Vardenafil	124
Xanthoanthrafil	124

COSMOSIL CN-MS

p-Acetamidophenol	31
Acetophenone	30
4'-Acetoxyacetanilide	31
p-Aminophenol	31
Benzene	30, 31
Caffeine	31
p-Chlorophenol	97
Clofibrate	97
DIDP	158
Diisodecyl Phthalate [DIDP]	158
Diisononyl Phthalate [DINP]	158
DINP	158
p-Ethoxyphenol	97
Methyl Benzoate	30
Theobromine	31
Theophylline	31
Toluene	30, 31

COSMOSIL C₂₂-AR-II

Acetophenone	30
Benzene	30
Methyl Benzoate	30
Toluene	30

COSMOSIL C₈-MS

Acetophenone	30
Benzene	30
Bisoprolol	110

Butyl p-Hydroxybenzoate	120
Cetirizine	101
Clindamycin Phosphate	97
Cyanocobalamin	99
Cyanocobalamin Derivative	99
1-(2,6-Dimethylphenoxy)-2-Propanamine [Mexiletine]	116
1,2-Dinitrobenzene	95
Dipyridamole	100
Domperidone	107
Ethyl p-hydroxybenzoate	107
Fumaric Acid	110
Ipratropium Bromide	94
Ipratropium Bromide Derivative	94
Lincomycin	97, 120
Methyl Benzoate	30
Methyl p-Hydroxybenzoate	97
Mexiletine	116
Minocycline	116
4-epi-Minocycline	116
Omeprazole	95
β-Phenylethylamine	116
Propyl p-Hydroxybenzoate	101
Rifampicin	120
Scopolamine	111
(-)-Scopolamine n-Butyl Bromide	111
p-Terphenyl	100
Toluene	30
Vincristine Sulfate	111
Vinyl Acetate	129
N-Vinyl-2-Pyrrolidone	129
Vitamin B ₁₂ [Cyanocobalamin]	99

COSMOSIL C₄-MS

Acetophenone	30
Benzene	30
Methyl Benzoate	30
Toluene	30

COSMOSIL TMS-MS

Acetophenone	30
Benzene	30
Daunorubicin	95
Doxorubicin	95
Epirubicin	95
Methyl Benzoate	30
2-Naphthalenesulfonic Acid	95
Ticarcillin	104
Toluene	30
o-Toluic Acid	104

I. HPLC Columns

II. UHPLC Columns

III. Preparative
Packing Materials

IV. Related Products

V. Applications

VI. Technical Notes

VII. Index

COSMOSIL PE-MS

Acetophenone	30
Anisole	202
Benz[a]anthracene	205
Benzene	30, 202
Berberine	25
Capsaicin	128
Chrysene	205
Cortisone	24
Daidzein	25
Daidzin	25
Dexamethasone	104
3-Ethoxy-4-Hydroxybenzaldehyde	116
Ethyl Vanillin [3-Ethoxy-4-Hydroxybenzaldehyde]	116
Genistein	25
Genistin	25
Glycitein	25
Glycitin	25
Hydrocortisone	24
Maleic Acid	104
Methyl Benzoate	30
Mitomycin C	116
Nitrobenzene	202
Palmitate	25
Prednisolone	24
Tetraphene [Benz[a]anthracene]	205
Timolol	104
Toluene	30
m-Tolunitrile	24, 202
o-Tolunitrile	24, 202
p-Tolunitrile	24, 202
N-Vanillylnonanamide	128

COSMOSIL SL-II

p-Acetamidophenol	122
Acetanilide	122
Benzoic Acid	34
β-Carotene	135, 139
Cetirizine	101
Cinnamyl Alcohol	34
Dantrolene	103
4-Dimethylaminoantipyrine	101
Fluocinolone Acetonide	113
Fluoxymesterone	112
Hydrocortisone	110
6α-Methylprednisolone	112
p-Nitrobenzyl Alcohol	34, 71
Phenacetin	122
L-α-Phosphatidyl Choline	146
Prednisone	110
Quinizarin	71

Salicylamide	34, 71
Salicylic Acid	34, 71
Theophylline	103
α-Tocopherol	139
β-Tocopherol	139
γ-Tocopherol	139
δ-Tocopherol	139
α-Tocotrienol	139
β-Tocotrienol	139
γ-Tocotrienol	139
δ-Tocotrienol	139
Tolazamide	106
Tolbutamide	106
Triamcinolone Acetonide	113
Vitamin A	139
Vitamin A Acetate, all trans	135
p-Xylene	34

COSMOSIL HILIC

Allantoic Acid	124
Allantoin	37, 124
Ammelide	37
Ammeline	37
Angiotensin II, [Asn ¹ ,Val ⁵]	151
Angiotensin II, [Sar ¹ ,Ile ⁸]	151
Angiotensin II, [Val ⁵]	151
Angiotensin II, Des-Asp1- [Ile ⁸]	151
L(+)-Ascorbic Acid [Vitamin C]	137, 138
Asn ¹ ,Val ⁵	151
L-Citrulline	132
Cyanuric Acid	37
Diethylene Glycol	159
L(+)-Ergothioneine	37
meso-Erythrite	159
meso-Erythritol [meso-Erythrite]	159
D-Fructose-6-phosphate	144
α-D-Glucose-1-phosphate	144
D-(+)-Glucose	144
D-Glucose-6-phosphate	144
DL-Glyceric Acid	159
Glycerol	158, 159
Glycine	36
Glycylglycine	36
D-Isoascorbic Acid	137
L-Isoleucine	37
Ile ⁸	151
L-Leucine	37
L-(-)-Malic Acid	132, 138
Melamine	37
Nicotinamide	137
Nicotinic Acid	137
Oxalic Acid	159

COSMOSIL HILIC

Oxamic Acid	159
D-Pantothenic Acid	137
Pyridoxine	137
Riboflavin	137
Sar ¹ , Ile ⁸	151
Sorbic Acid	137
Taurine	150
Tris(hydroxymethyl)aminomethane	159
Uracil	158
Urea	159
Uridine	158
L-Valine	37
Vitamin B ₂ [Riboflavin]	137
Vitamin B ₆ [Pyridoxine]	137
Vitamin C	137, 138

COSMOSIL Sugar-D

D-(-)-Arabinose	39
CDDP	123
α-Cyclodextrin	142
β-Cyclodextrin	142
γ-Cyclodextrin	142
meso-Erythrite	39, 142, 143
meso-Erythritol [meso-Erythrite]	39, 142, 143
1-Fructofuranosyl-D-nystose	40
D-(-)-Fructose	39, 40, 142, 143
D-(+)-Galactose	39
D-Glucitol	39, 143
D-Glucitol [Sorbitol]	143
D-(+)-Glucose	38, 39, 40, 142, 143
Glycerol	39
Guanosine	123
myo-Inositol	39, 143
Isomaltooligosaccharides	142
1-Kestose	40
Lactose	41, 143
Maltitol	39, 142, 143
Maltoheptaose	40
Maltohexaose	40
Maltopentaose	40
Maltose	38, 39, 40, 41, 142, 143
Maltotetraose	40
Maltotriitol	143
Maltotriose	40, 143
D-(-)-Mannitol	143
D-Mannosamine	40
D-(+)-Mannose	40
Nystose	40
Palatinit	143

Palatinose	142
cis-Platin [CDDP]	123
D-(+)-Raffinose	39, 142
Rebaudioside A	40
L-(+)-Rhamnose	39, 40
Sorbitol	143
Stevioside	40
Sucrose	39, 41, 142, 143
D-(+)-Trehalose	41, 142
Xylitol	39, 142, 143
Xylooligosaccharides	142
D-(+)-Xylose	40

COSMOSIL NH₂-MS

D-(-)-Arabinose	39
D-(-)-Fructose	40
D-(+)-Galactose	39
D-(+)-Glucose	38, 40
Lactose	41
Maltitol	39
Maltose	38, 41
D-(+)-Mannose	40
L-(+)-Rhamnose	40
Sucrose	41
D-(+)-Trehalose	41
D-(+)-Xylose	40

COSMOSIL Protein-R

Actinase E	152
Albumin, Bovine [BSA]	42, 152
Albumin, Egg [Ovalbumin]	42, 153
Albumin, Goat	153
Albumin, Human	152
Albumin, Rabbit	153
Alcohol Dehydrogenase	152
α-Amylase	152
Angiotensin I (Human)	150
Angiotensin II (Human)	150
BSA	42, 152
Carbonic Anhydrase	152
Catalase	153
Choline Oxidase	152
α-Chymotrypsinogen A	153
Conalbumin	153
Concanavalin A	153, 154
Cytochrome C	42, 153
Deoxyribonuclease I	153
Diaphorase	154
Fibrinogen	153
Glucose Oxidase	152
L-Glutamic Dehydrogenase	152

COSMOSIL Protein-R

Lysozyme	42, 153
Milk	152
Myoglobin	42, 153
Myosin	151
Ovalbumin	42, 153
Oxytocin	150
pd(T) ₁₂₋₁₈	148
Peroxidase	153
Poly-L-Glutamic Acid Sodium Salt	43
Pyruvate Kinase	153
Recombinant human tau	154
Ribonuclease A	42, 153
Soybean milk	152
Substance P	150
Thermolysin	152
Thyroglobulin	153
Transferrin	152

COSMOSIL C₁₈-AR-300

[Ala ²]-Leucine-Enkephalin	151
[Ala ²]-Methionine-Enkephalin	151
AngiotensinII	151
Bombesin	151
Bradykinin	151
Carbonic Anhydrase	45
α-Chymotrypsinogen A	45
Hemoglobin Bovine	44
Insulin	45
Leucine-Enkephalin	151
Methionine-Enkephalin	151
Neurotensin	151
Substance P	151
Transferrin	45
Trypsin Inhibitor	45
Trypsinogen	45

COSMOSIL C₈-AR-300

Carbonic Anhydrase	45
α-Chymotrypsinogen A	45
Hemoglobin Bovine	44
Insulin	45
Transferrin	45
Trypsin Inhibitor	45
Trypsinogen	45

COSMOSIL C₄-AR-300

Carbonic Anhydrase	45
α-Chymotrypsinogen A	45

Hemoglobin Bovine	44
Insulin	45
Transferrin	45
Trypsin Inhibitor	45
Trypsinogen	45

COSMOSIL Ph-AR-300

Carbonic Anhydrase	45
α-Chymotrypsinogen A	45
Hemoglobin Bovine	44
Insulin	45
Transferrin	45
Trypsin Inhibitor	45
Trypsinogen	45

COSMOSIL Diol-120-II

Aprotinin	46
Conalbumin	46
Glucose Oxidase	46
Myoglobin	46
Peroxidase	46
Thyroglobulin	46

COSMOSIL Diol-300-II

Angiotensin II (Human)	47
Aprotinin	46
Bovine Serum	154
Conalbumin	46
Egg White	154
Glucose Oxidase	46
Hemoglobin, Human	47
Human Serum	47, 154
Myoglobin	46
Peroxidase	46
Thyroglobulin	46
Transferrin	47

COSMOGEL IEX Series

Anti-6xHis(Mouse IgG1-k),	155
Cytochrome C	48, 49
DNA	148
E.coli Proteins	155
Egg White	155
β-Galactosidase	48
HeLa Cell Proteins	155
His-tag Protein in 20mmol/l Tris buffer(pH8.0)	50
Lysozyme	49
Monoclonal(HI154),AS	155
Ribonuclease A	48, 49

COSMOGEL IEX Series

Trypsin Inhibitor	48
Trypsin Inhibitor from Soybean	50
Urease	155

COSMOSIL HIC

Albumin, Bovine [BSA]	51
BSA	51
β -Glucosidase	51
Hemoglobin Bovine	51
β -Lactoglobulin	51
Myoglobin	51

COSMOSIL Buckyprep

C ₆₀	52, 54, 57
C ₆₀ O	54
C ₇₀	52, 54
C ₇₆	54
C ₇₈	54
C ₈₄	54
C ₈₆	55
Crude fullerenes	56
Fullerene toluene extract	53
Gd@C ₈₂ (I)	55
PCBB	57
PCBM	57
[6,6]-Phenyl-C ₆₁ Butyric Acid Butyl Ester [PCBB]	57
[6,6]-Phenyl-C ₆₁ Butyric Acid Methyl Ester [PCBM]	57
Sc ₂ @C ₇₆ (I)	55
Sc ₂ @C ₇₈	55
Sc ₂ @C ₈₀ (I)	55

COSMOSIL Buckyprep-M

C ₆₀	52
C ₇₀	52
C ₈₆	55
Gd@C ₈₂ (I)	55
Sc ₂ @C ₇₆ (I)	55
Sc ₂ @C ₇₈	55
Sc ₂ @C ₈₀ (I)	55

COSMOSIL PBB

C ₆₀	52, 56, 57
C ₇₀	52, 56
C ₇₆	56
C ₈₄	56
Crude fullerenes	56
PCBB	57

PCBM	57
[6,6]-Phenyl-C ₆₁ Butyric Acid Butyl Ester [PCBB]	57
[6,6]-Phenyl-C ₆₁ Butyric Acid Methyl Ester [PCBM]	57

COSMOSIL CNT-300

DNA-wrapped CNT	58
-----------------------	----

COSMOSIL CNT-1000

DNA	148
DNA-wrapped CNT	58
Hyaluronic Acid	144

COSMOSIL CNT-1620

DNA	148
DNA-wrapped CNT	58

COSMOSIL C₁₈-OPN

Caffeine	68
p-Cresol	68
p-Ethylphenol	68
Theobromine	67, 68
Theophylline	67, 68

COSMOSIL C₁₈-PREP

Baicalein	70
Baicalin	70
DL- α -Tocopherol	70
DL- α -Tocopherol Acetate	70
Wogonin	70

COSMOSIL SL-II -PREP

p-Nitrobenzyl Alcohol	71
Quinizarin	71
Salicylamide	71
Salicylic Acid	71

Silica gel 60

Methyl Benzoate(Standard)	72
Sample A	72
Sample B	72

Product Search

Has over **7,500** products
Has various search methods

- Product Name
- CAS No.
- Product Number
- Structural Formula
- Molecular Formula
- Numerical Value Range (Molecular weight, Melting point and etc.)
- Application etc.

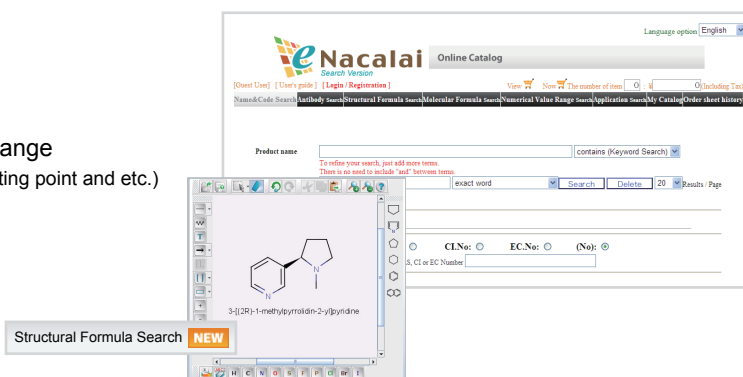

Structural Formula Search **NEW**

Product Information

Has the latest information
Saves time for inquiry

- The latest inventory
- MSDS
- Characteristic
- Product picture
- Instruction
- Brochure
- Chromatogram Index (HPLC)
- Specification*
- Certificate of Analysis*
- Product label* etc.

*Registration is required

Product number	3802-11																		
Product name	COSMOSIL® 90-19-HG-II Packed Column: 10mmID, x 250mm																		
Manufacturer	NACAL TESQUE INC.	Grade	Special Prepared for specific use (D1 type with Prepacked Reagent)	Product appearance	MSDS (JP)	MSDS (EN)	Product specification	Product information (JP)	Product information (EN)										
Application	SP Application		for HPLC	COA(JP)	COA(EN)	HPLC	Product Label	Reagent appearance	Packaging material	Under construction									
PEG size	1PFG			Instruction(JP)	Instruction(EN)	Structural formula	Product form												
Stock	2 - 5		Estimated delivery time	The next business day															
List price(Yen)																			
Storage																			
Single / Mixture																			
CAS Number	MDL Number																		
Component content	Enzyme Code																		
Note on composition																			
Purity																			
Analytical method	EINECS																		
Molecular weight	UN Number																		
Molecular Formula	ACQID																		
Rational Formula																			
Appearance	BSCS No.																		
Form	RTECS																		



Search Now !

Visit our website at www.nacalai.com

e-Nacalai Global

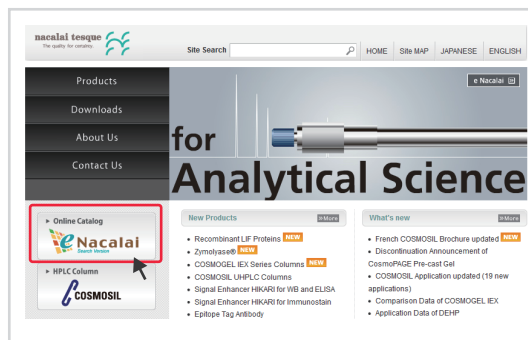

e-Nacalai is free service (No registration)

Warranties and Disclaimers:

Nacalai Tesque warrants that its products shall conform to the description of such products as provided by Nacalai Tesque through its catalog, analytical data or other literature. Nacalai Tesque makes no other warranty, express or implied, as to the fitness of these products for any particular purpose. Nacalai Tesque shall not in any event be liable for incidental or consequential damages that may result from any use or failure of the products.

For more information on products and pricing, please contact your local distributor.

NACALAI TESQUE, INC.

Nijo Karasuma, Nakagyo-ku, Kyoto 604-0855 JAPAN

TEL : +81 (0)75 251 1730

FAX : +81 (0)75 251 1763

E-mail : info.intl@nacalai.com

www.nacalai.com